

TEXT BOOK OF BIOCHEMISTRY

For 1st year Medical Laboratory Technician Course
(Intermediate Vocational)

Author :

S. Srinivasa Rao, B.Pharmacy,
Jr. Lecturer in Medical Lab Technology,
Alluri SriRama Raju Govt. Junior College,
Shanthi Nagar, Khammam.

Editor :

S. Kamalakar Rao, M.Pharmacy
Senior Lecturer in Biotechnology
Govt. Institute of Post Diploma Courses in Engineering & Technology
Ramanthapur, Hyderabad.

INDEX

Chapter	Page No.
1. Introduction to Bio-Chemistry including code of ethics for Medical Lab Technicians and Medical Lab Organisation.....	1
2. Reception, Registration and Biochemical Parameters investigated	5
3. Glassware and Plasticware used in a Biochemical laboratory	15
4. Instrumental methods of Biochemical Analysis	39
5. Basic Lab Operations	59
6. Water, Chemicals and related substances	76
7. Prevention, Safety and First-Aid in lab accidents	92
8. Collection of Specimens	108
9. Urine Biochemical parameters	124
10. Units of measurements	141
11. Solutions	148
12. Carbohydrates and Lipids	171
13. Amino Acids and Proteins	183
14. Diagnostic Tests	194
15. Vitamins and Minerals	226

1. INTRODUCTION TO BIOCHEMISTRY INCLUDING CODE OF ETHICS FOR MEDICAL LAB TECHNICIANS AND MEDICAL LAB ORGANISATION

Biochemistry : Biochemistry is the science of study of chemical reactions taking place in living cells. It explains the complex processes of life from the smallest virus to the most complex and highly evolved human being. It explains the composition of living cells, functions of different components of the cells. Chemical constituents in the cell are both organic and inorganic. Determination of those substances in different body fluids is needed to assess the functioning of body organs and systems. For the state of normal functioning, values of the constituents such as Glucose, Urea, Uric acid in blood will be within certain limits. In case of abnormal functioning, their values in blood and other body fluids will deviate from normal.

Clinical Biochemistry is the application part of Biochemistry for diagnosis of the clinical condition by determining various constituents in different body fluids. Determination can be qualitative or quantitative. Different body fluids used for diagnosis include Blood / plasma / serum, urine, C.S.F., sputum, stools, semen etc. For example, quantitative determination of glucose in blood, its qualitative identification and quantitative determination in urine help in the diagnosis of diabetes mellitus. Quantitative determination of urea and creatinine in blood and urine help in the assessment of kidney functioning.

Study of Biochemistry requires base in inorganic, organic and physical aspects of chemistry since the cellular components are inorganic and organic substances. Entry of these substances into and out of cell involve physico chemical principles and hence basic knowledge in these areas is also essential. Firm base in analytical chemistry is also a requisition for a Clinical Biochemist since clinical part of Biochemistry is analysis of biological fluids.

Bio chemistry has applications in various fields - Medicine, Pharmacy, Veterinary Science, Dentistry, Agriculture, Dairying etc. Biochemical approaches are strengthening different disciplines as Micro biology, Botany, Zoology, Genetics etc.

Code of ethics for Medical Lab Technicians :

Lab technician should follow certain ethics and abide by the code of conduct to discharge his duties perfectly.

1. **Punctuality :** Lab worker should maintain punctuality in attending the duty. In case of emergency calls, maintenance of punctuality is quite essential as it saves the life of the patient.
2. **Promptness :** Lab worker should be prompt in his work. Postponement of the work delays diagnosis and thus treatment.
3. **Accuracy :** Lab workers should maintain accuracy and correctness in reporting. Guessings and assumptions should not be done in reporting. Exhaustive methods be followed for accuracy in analysis.
4. **Confidentiality :** Clinical revealings should be maintained confidential with the Doctor. They should not be disclosed to the patient, patients relations or others.
5. **Courtesy :** Courteous, kind and sympathetic approach should be followed towards the patient and patient's attendants.
6. **Technician should be loyal and obedient to the superiors -** Superintendent, Deputy superintendent, Pathologist, Biochemist & Micro Biologist, Blood bank medical officer and Medical officer to discharge the duties correctly.
7. **Harmony :** Technician should maintain good relations and work in harmony with colleagues - specialists, nursing staff, pharmacy staff and office staff.
8. **Generosity :** Technician should be generous and kind to the subordinates - lab attendants, ward boys so as to extract their services promptly.
9. **Sincerity :** Technician should maintain sincerity in the profession. Unlawful methods of earning should not be followed.
10. **Acquaintance with safety procedure :** Technician should be acquainted with the safety procedures to be followed in the lab for preventing lab accidents and first aid measures in case of lab accidents. It will help the personal safety as well as safety of fellow technicians.

11. Continuing education : Technician should always be knowing the advancements through journals, books and literature so as to be able to perform advanced methods, when the need arises. Improvement of professional knowledge will help in delivering the duties more accurately and to elevate professional status.
12. Standards : Technician should maintain high standards in work to elevate the status of profession and reputation.

Medical Lab Organisation :

Medical Laboratory in big hospitals is divided into different specialities. They are 1) Clinical Pathology 2) Haematology 3) Biochemistry 4) Micro Biology and Serology 5) Histo Pathology and Cytology 6) Blood Bank and Immuno Haematology.

Basically all these specialities require technicians. In general, they are called Medical Lab Technicians. Lab technicians working in Histopathology lab is called Histo technician. Lab technician working in Blood Bank is called Blood Bank technician.

Biochemical Lab work is supervised by Biochemist. Microbiological work is supervised by Microbiologist. Blood Bank work is supervised by Blood Bank Medical Officer. All these specialities on the whole are supervised by Pathologist, whose qualification should be MD (Pathology) or relevant.

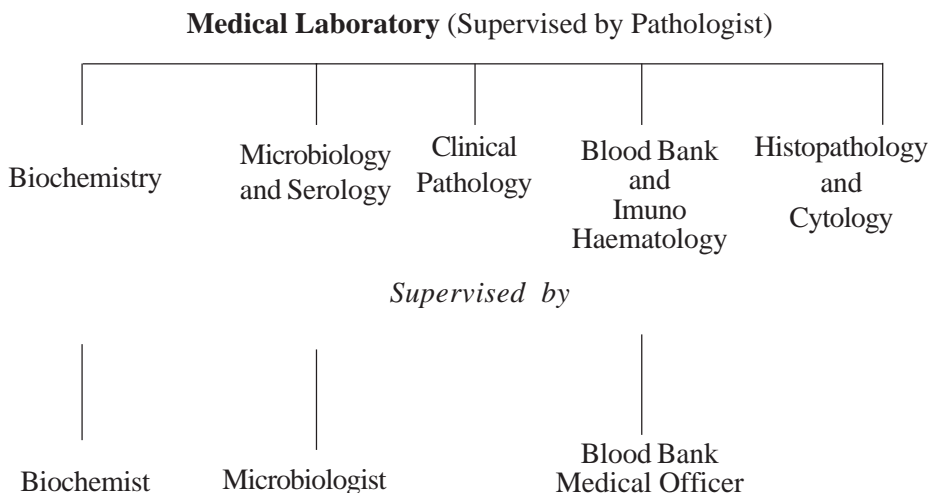

SUMMARY

Biochemistry is the science of study of Biochemical reactions taking place in living matter. Application part of biochemistry for diagnosis of diseases is called as clinical biochemistry. Biochemistry finds application in the fields of Medicine, Pharmacy, Veterinary science, Dentistry, Agriculture etc. Biochemical aspects enrich different disciplines as Microbiology, Botany, Zoology, Genetics etc.

A lab technician has to follow certain ethics and abide by the code of conduct. Discipline is requisite thing for a lab worker. Requisite qualities in ethical professional conduct of a lab technician are 1) Punctuality 2) Promptness 3) Accuracy 4) Confidentiality 5) Courtesy 6) Loyalty 7) Harmony 8) Generosity 9) Sincerity 10) Acquaintance with safety procedures 11) Continuing education 12) Maintaining standards.

Medical Lab is divided into different specialities like Bio-Chemistry, Micro Biology and Serology, Clinical Pathology, Blood Bank and Imuno Haematology and Histopathology - Cytology.

Essay Questions

- 1) Write about introduction of biochemistry.
- 2) Discuss the code of ethics for medical lab technicians.
- 3) Write about medical lab organisation.

Short Questions

- 1) Define biochemistry.
- 2) Define clinical biochemistry.
- 3) What are the fields of application of bio-chemistry?
- 4) Mention the disciplines which are enriched with biochemical approaches.
- 5) Mention any two things of requisition in the code of Ethical Professional conduct for a lab technician.
- 6) What is a histo-technician ?
- 7) What is the role of pathologist ?
- 8) Who will supervise a) biochemical work? b) Microbiological work?
- 9) Who will supervise Blood Bank work?

2. RECEPTION, REGISTRATION AND BIOCHEMICAL PARAMETERS INVESTIGATED

Reception and Registration:

When a patient approaches a doctor, patient is examined by the doctor. Doctor records clinical history, notes the findings of his examination and orders diagnostic tests. Diagnostic tests ordered to be conducted are written over a format called as lab order form / lab requisition form. In this country, it is part of the out patient slip for out patients and as part of case sheet for inpatients.

Out Patient : A patient whose clinical condition does not need hospitalisation and is given treatment by patient staying at home itself and visiting the hospital as decided by the doctor is called as out patient.

In Patient : A patient whose clinical condition needs hospitalisation and is given treatment by patient staying in the hospital ward is called as inpatient.

Lab order form / Lab requisition form : The form on which lab tests are written by the doctor is called as lab order / requisition form.

Contents of lab order form : Details such as hospital address, name of the patient, age of the patient, sex, date, O.P.no./I.P. no., Unit etc. are written on the upper column of the lab order form. Investigations to be ordered are written in the lower column of the lab order form.

When the lab order form is received in the lab, details are entered into lab register, tests are distributed between different sections such as Haematology, Pathology, Biochemistry, Microbiology etc.

Lab register : Register into which details such as date, I.P./O.P. no., name of the patient, age, sex, ward, nature of the test, name of the specimen, report findings are entered is called as lab register.

After recording the data in the register, technician collects specimen from patient. Each specimen is labelled for identification and specimen label contains details as name of patient, O.P./I.P. no., name of the test, type of specimen etc. After testing the specimen, report is submitted to the referring doctor and findings of the tests are entered into the lab register and signed by the technician.

PROFORMA OF A LAB ORDER FORM:

SAROJ HOSPITALS, WASHINGTON	
Name
Age	Sex Date
O.P. / I.P. No.	Unit .:
Investigations Ordered :	

PROFORMA OF A LAB ORDER FORM as part of Out Patient Slip:

RAJ HOSPITALS, KHAMMAM.	
OUT-PATIENT SLIP	
Name
Age	Sex Date
O.P. / I.P. No.	Unit .:
Clinical History :	
Examination Findings :	
Provisional Diagnosis :	
Investigations Ordered :	

LAB ORDER FORM as part of CASE SHEET :

Front page of Case Sheet containing details of the patient admitted is given below.

SAI SAMRAT INSTITUTE OF MEDICAL SCIENCES,

HYDERABAD.

CASE RECORD

Regd. No. _____ Ward _____ Received at { Date
Time

Service _____

Name _____ Bed No. _____ Serial No. _____

Father / Husband _____ Diagnosis { Provisional
Final

Age _____ Sex _____

Occupation _____ Date of Admission _____

Religion _____ Date of Operation /Delivery _____

Address _____ Date of Discharge _____

_____ Result _____

Phone No. (Nearest) _____

Admission { Date
Time

Clinician's Notes

Notes of the Head of Dept.

Inner page of the Case Sheet containing Lab Tests ordered is given below.

Date	Blood	Date	Urine	Date	X-Ray	Date	Special Investigation

Proforma of Lab Register Form :

CHANDRAKANTH HOSPITALS, WARANGAL

LAB DIAGNOSTIC SERVICES REGISTER

Date	I.P./O.P.No.	Name	Age	Sex	Ward	Nature of the Test	Name of the Specimen	Reports Finding with Sign.

Biochemical parameters are physical characteristics, concentrations of chemical constituents like glucose, creatinine in biological fluids like Blood / serum / plasma, urine, C.S.F. etc. Deviation from these ranges indicates diseased condition.

1. Fasting Blood sugar :
80-120 mg / 100 ml.(Folin and wu method)
Fasting Blood sugar :
70-110 mg/100 ml.(O-Toluidine method)
75-115 mg/100 ml. (Glucose Oxidase - Peroxidase method)
Post Prandial Blood Sugar (2 hours after lunch):
up to 130 mg/100 ml. (O-Toluidine method)
2. Urine glucose (Benedict's quantitative): 50-200 mg/24 hrs.
3. Glycosylated Haemoglobin - Normal range : 4-7%
4. Serum urea Nitrogen (DAM method):
Normal range 7-23 mg/dL.
5. Urine urea Nitrogen (DAM method):
10-15 g in 24 hours.
6. Serum urea Nitrogen by Berthelot reaction method: 5-21 mg/ dL
7. Serum creatinine by Alkaline picrate method : 0.7 - 1.7 mg./dL
8. Urine creatinine by Alkaline picrate method : 1.5 to 3 g / 24 hrs.
9. True creatinine (serum) by alkaline picrate method: 0.6-1.2 mg/dL
10. Serum uric acid by Henry-Caraway's method: 3-7 mg%
11. Urine uric acid by Henry-Caraway method: 0.6-1 g/24 hrs.
12. Serum proteins (Total) by Biuret method : 6-8 g/dL.
13. Serum albumin by Bromocresol green method : 3.3-4.8 g%
14. Serum globulin by Bromocresol green method : 1.8 - 3.6 g%

15. Normal range of A/G ratio (Albumin-Globulin ratio): 12:1 to 2:1
16. Normal range of CSF proteins by turbidimetric method : 15-45 mg%
17. Normal range of urinary proteins by turbidimetric method:
chemically detectable proteins are absent in urine of normal individual.
18. Normal range of alpha-1-globulin by Biuret method : 0.2-0.4 g%
19. Normal range of alpha-2-globulin by Biuret method : 0.4-0.8 g%
20. Normal range of Beta-globulin by Biuret method : 0.6-1.2 g%
21. Normal range of Gama-Globulin by Biuret method: 1-1.8 g%
22. Normal range of Serum acid phosphatase by Gutman & Gutman method: -
1-3.5 KA units%
23. Total acid phosphatase by PNP method : 0.9-12 I.U.
24. Prostatic acid phosphatase by PNP method : 0-4 I.U.
25. Normal range of Serum Alkaline phosphatase: 3-13 K.A. units %
26. Normal range of Serum alkaline phosphatase by PNP method:
20-90 I.U. % (Adults) ; 93-221 I.U % (Children)
27. Normal range of SGOT 8 to 40 K.U.
28. Normal range of SGPT 5 to 35 K.U.
29. Normal range of serum amylase by Amyloclastic mehtod(Iodometric): 60-
180 C.U.
30. Normal range of serum lactate dehydrogenase (SLDH) by King's
colorimetric method : 70-240 I.U.
31. Normal range of serum bilirubin (Malloy - Evelyn) method Total bilirubin:
upto 1 mg%
32. Normal r l ange of serum bilirubin (Malloy - Evelyn) method Direct bilirubin:
upto 0.5 mg%
33. Normal range of serum indirect bilirubin (Malloy - Evelyn): upto 0.5 mg%

34. Icterus index: 4-6.
35. Normal range of serum total cholesterol by watson method :150-250 mg%
36. Normal range of serum HDL cholesterol:
Men - 30-60 mg% , Women - 40-70 mg%
37. Normal range of serum triglycerides by Acetyl-Acetone method : 10-190 mg%
38. Normal range of serum total lipids by Sulphoso vanilline method (fasting): 400-1000 mg%
39. Normal range of serum creatine phosphokinase by modified Huge's method:
Men : 20-50 I.U. Women : 10-37 I.U.
40. Normal range of serum inorganic phosphorous by Gomorri's method:
Adults - 2.5-4.5 mg% Children - 4.0 - 7.0 mg%
41. Normal range of urine inorganic phosphorous by Gomorri's method: 1g/24 hrs.
42. Normal range of serum calcium by Cresolphthalein complexone method : 9-11 mg%
43. Normal range of urinary calcium by Cresolphthalein complexone method :
100-300 mg per 24 hrs.
50 - 150 mg per 24 hrs.
44. Normal range of serum sodium by flame photometric method :133-148 meq/L.
45. Normal range of serum potasium by flame photometric method : 3.8-5.6 meq/L
46. Serum lithium (FPM) : 0.003 meq/L.
47. Urinary sodium (FPM) : 120 meq/L in 24 hrs.
48. Urinary potassium (FPM): 40 me/L in 24 hrs.
49. Serum chlorides (FPM): 95-106 meq/L.

50. CSF chlorides (FPM): 700-750 meq/L.
51. Urinary chlorides(FPM) :120-250 meq/L.
52. pH of peripheral blood : 7.36 to 7.42.
53. pH of Arterial blood :7.40.
54. Oxygen tension in alveolar air : 107 mm Hg.
55. Oxygen tension in venous blood : 40 mm Hg.
56. CO2 tension in venous blood: 46 mm Hg.
57. Serum bicarbonate : 21-28 meq/L.
58. Testosterone secretion - Males : 0.6 m g% ; Females : 0.03 m g%
59. Growth hormone : 0-5 ng/ml plasma
60. Tri Iodothyronine : 0.7-2ng/ml.
61. Thyroxine : 48-115 ng/ml.
62. TSH: 0-10 M.I.U./ml. Neonates by third day after birth
<25 m.I.U./ml.
63. FSH - Male : 2-25 m.I.U. / ml. Female 40-30 m.I.U. / ml.
Postmenopausal women : 40-250 m.I.U. / ml.
64. LH: 7-24 m I.U. / ml. men; 6-30 m.I.U. / ml. women
65. Prolactin : Male : 5-18 ng./ml. Female: 6-22 ng./ml.
66. Insulin: 30 min. after glucose - 25-231 mcU/ml.
60 min. after glucose - 18-276 mcU/ml.
120 min. after glucose - 16-166 mcU/ml.
67. Renin - 0.4-4.5 ng/ml.
68. Progesterone - Male < 100 ng%
Female < 150 ng% (Follicular phase)
300 ng% (Leutal phase)
1,500-5,000 ng% (First trimster)

Rise is observed during gestation and in third trimester.

Conditions of deviation: Conditions of deviation of the normal ranges of the biochemical parameters indicate certain disorders.

For ex: 1. In jaundice, bile is obstructed from being secreted into intestines and thus it goes into blood and increases serum bilirubin values above the normal limit.

2. In diabetes mellitus, glucose is not properly utilised by the cells of body and thus its value increases above normal value in blood, the condition being called as hyperglycaemia.
3. Condition of decreased value of glucose below the normal range is called as hypoglycaemia.
4. Condition of increased uric acid level in serum above the normal value is hyperuricaemia, which is seen in Gout, Renal failure and leukaemia.
5. Serum creatinine is increased in renal failure, congestive cardiac failure, shock and mechanical obstruction of urinary tract.
6. Elevated levels of blood urea are observed in diabetes mellitus. Cardiac failure, dehydration, kidney diseases, prostate enlargement, stones in urinary tract etc., where as decreased values are observed in severe liver disease, protein malnutrition and pregnancy.

SUMMARY

Biochemical parameters are normal ranges of physical characteristics, concentrations of chemical constituents in body fluids. Deviation of these ranges indicates diseased condition. For example: Serum bilirubin values are increased above normal range in jaundice. Blood glucose values are increased above normal values in diabetes mellitus. In hypoglycaemia blood glucose values are decreased below normal.

Essay Questions

- 1) Write about reception and registration.
- 2) What is a biochemical parameter? What does the deviation of a parameter indicate?

- 3) Exemplify some conditions causing deviations of biochemical parameters.

Short Answer questions:

- 1) Give the normal values of blood sugar in fasting and postprandial blood specimens.
- 2) Give the normal values of serum urea nitrogen by DAM method.
- 3) What is the normal range of serum bilirubin (direct) by Malloy and Evelyn method?
- 4) Give the range of Icterus index.
- 5) What are the normal ranges of serum HDL cholesterol in men and women?
- 6) Give the normal range of serum sodium by flame photometric method.
- 7) Mention oxygen tension and CO₂ tension in venous blood.
- 8) Mention the normal values of chlorides in serum, C.S.F. and urine.
- 9) What are normal values of Triiodo thyronine and thyroxine?
- 10) What is the normal range of specific gravity of urine?
- 11) What is lab order form?
- 12) Define lab register?
- 13) Define a) out patient b) in-patient

3. GLASS WARE AND PLASTIC WARE USED IN A BIOCHEMICAL LABORATORY

Different glass and plastic containers and apparatus are used in a laboratory. They are used for various purposes as measuring, transfer of substance from container to container, filtration etc.

1. Glass ware : Glass ware are used for different purposes as measuring, transfer of substances from container to container, filtration, boiling, condensation etc. During these operations they are exposed to the chemicals contained in them. Glass used for manufacture of these glass ware must be resistant to the action of chemicals - Acids, alkalies, etc. They must also withstand the mechanical rigors during handling, operation and the effect of sudden changes of temperature during boiling, refluxing etc.

Composition of glass :

Pure silica	Sodium carbonate
Broken glass	Boron oxide
Lead	Alumina

Broken glass acts as fusion agent. Reduction in the quantity of sodium ions renders the glass chemical resistance. Without alkalies, melting the glass is expensive and difficult task. Boron oxide reduces the temperature required for melting the glass. Trace quantities of lead gives clarity and brilliance. Alumina imparts hardness, increased resistance to chemical action and durability.

Types of glass:

1. Borosilicate glass
2. Treated soda lime glass
3. Regular soda lime glass
4. General purpose soda lime glass

1. Borosilicate Glass:

Glass ware used in laboratory is generally manufactured with Borosilicate glass. It is resistant to the action of chemicals and effects of sudden changes of temperature during boiling, refluxing etc. However it is not resistant to the action of hydro fluoric acid. This highly resistant glass is made by replacing alkali and alkaline earth cations by boron / aluminium and Zinc. It is chemically more resistant than soda-lime glass. It is composed of silica - 80.6%, boron

oxide 12.6%, sodium oxide 4.15% and Alumina - 2.2% .Addition of boron reduces leaching action.

2. Treated Soda Lime Glass:

Soda lime glass subjected to the treatment by an atmosphere containing water vapour and sulphur dioxide at elevated temperature is called as Treated Soda lime Glass. This type of treatment is called as sulphur treatment and it protects the glass from blooming or weathering.

Blooming : When glassware is exposed to the atmosphere of dampness and extreme temperature variations, moisture condensing on the surface of the glass subjects the glass to continuous and prolonged wetting causing salts to come out of glass giving the appearance of fine crystals on the glass. This effect is called as blooming or weathering.

Regular Soda-lime Glass :

This is commercial glass. It is not subjected to sulphur treatment. It has average to better than average chemical resistance.

General purpose Soda lime Glass :

This is soda-lime glass used for general purpose.

Types of laboratory glassware:

1. Graduated glassware
2. General glassware

Graduated glassware:

1. Graduated flasks
2. Pipettes
3. Burettes
4. Weight burettes
5. Measuring cylinders

General Apparatus :

1. Beaker
2. Flasks
3. Tubes
4. Syringes
5. Separating funnels
6. Funnels
7. Condensers
8. Dessicators

- | | |
|-------------------|----------------------|
| 9. Bottles | 10. Wash bottles |
| 11. Stirring rods | 12. Weighing bottles |
| 13. Watch glass | 14. Weighing funnel |

Graduated glassware :

Glassware which have graduations on them and intended for purposes as containing, delivering etc. and which are used in accurate measurements for use in volumetric analysis are called as graduated glassware.

Types of graduated apparatus :

In Great Britain two grades of apparatus are available. They are

- | | |
|------------|------------|
| 1. Class A | 2. Class B |
|------------|------------|

Class A apparatus is used in work of highest accuracy. Class B apparatus is used in routine work.

Graduated flasks : They are also known as Volumetric flasks. They are two types. 1. To contain (TC) type 2. To deliver (TD) type. TC type flasks are accurate for quantitative work.

1. It is flat bottomed.
2. It is pear shaped.
3. It has a long narrow neck.
4. A thin line is etched around the neck. It indicates the volume it holds at definite temperature - usually 20°C.
5. It has a glass stopper.

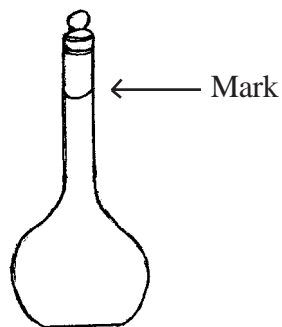

Uses : They are used in making up final volume of standard solutions.

Pipettes : Pipettes are of two kinds.

1. Transfer pipettes
2. Measuring pipettes

Transfer pipettes :

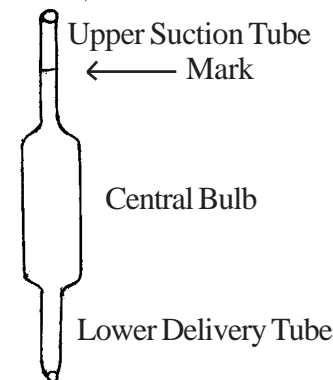

They are also called as Volumetric Pipettes.

Transfer pipettes consist of a central cylindrical bulb joined at the both ends to narrow tubing. It has three parts 1. Upper suction tube 2. Central cylindrical bulb 3. Lower delivery tube.

Upper suction tube contains a mark etched around. When a liquid is pipetted up to this mark, liquid will be of the volume, the pipette is specified to contain. Lower tube is drawn out to a fine tip. Transfer pipettes are constructed with capacities of 1, 2, 5, 10, 20, 25, 50 and 100ml.

Uses : These pipettes are useful for delivering specific quantity of liquid. They are very accurate in quantitative work.

Handling of Corrosive / Toxic liquids with transfer pipettes : Some attachments consist of a rubber or plastic bulb with glass ball valves. Valve can be operated between thumb and finger. Griffin pipette filler provides this type of arrangement.

In some devices, piston control is provided. In exelosafety pipette, barrel control is provided.

Measuring pipettes: They are also called as graduated pipettes. They do not contain a central bulb. There are three types of graduated pipettes



1. Type 1 graduated pipettes
2. Type 2 graduated pipettes
3. Type 3 graduated pipettes

1. Type 1 graduated pipettes : They deliver required volume from top zero mark to selected graduation.
2. Type 2 graduated pipettes : They deliver measured volume from selected graduation to the tip of delivery.
3. Type 3 graduated pipettes : They are designed to remove selected volume of solution, thus to contain the capacity from tip of delivery to the selected graduation.

Uses: They can be used to deliver variable volume of liquid in the range of volume specified for the pipette. However they are not employed in accurate work where burette is preferred.

Serological Pipettes : Serological pipettes are graduated pipettes used for pipetting serum, blood, plasma, standard solutions, distilled water etc. They are marked upto the tip. 0.1 ml. & 0.2 ml. pipettes are used for pipetting serum, blood, plasma etc

Mohar pipettes: Mohar pipettes are pipettes graduated above the tip. So that they can be used even the tip is broken. They have similar applications as serological pipettes. However they are not as accurate as serological pipettes.

Folin-Ostwald Measuring (Vol) pipettes : They are volumetric / Transfer pipettes for measuring specific volume of liquid. They are useful in accurate quantitative works.

Blood pipettes:

They are:

1. R.B.C. pipette used in Erythrocyte count.
2. W.B.C. pipette used in T.C. of Leucocytes
3. Hb - pipette used in H.b estimation
4. E.S.R. pipette used in determination of erythrocyte sedimentation rate.

1. R.B.C. Pipette :

It is a pipette with a red bead in the central bulb. There are two marks etched around the lower tube - below the bulb - 0.5 & 1. The mark etched around upper tube above the bulb is 101. Rubber tube connected to the upper suction tube aids in pipetting.

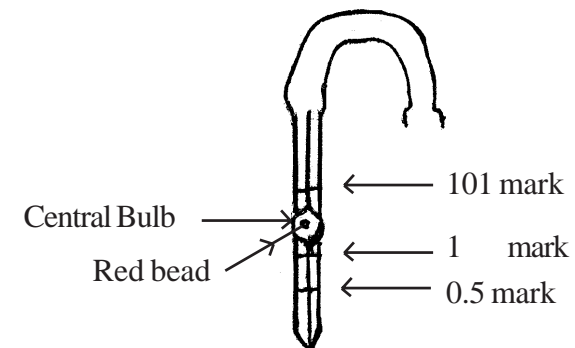

Blood is sucked up to 0.5 or 1 mark and diluting fluid is sucked up to 101 mark. Red bead helps in identification of the pipette and also in uniform mixing of blood and diluting fluid. When clotting of blood occurs in the lower delivery tube, a fuse wire may be used to remove the clot.

Uses : It is used in R.B.C. count.

2. W.B.C. Pipette :

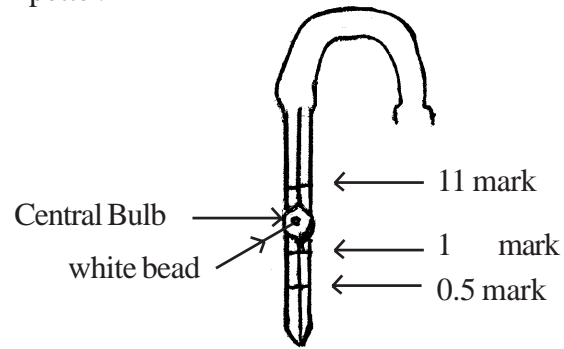

It is a pipette with a white bead in the central bulb. There are two marks etched around the lower delivery tube - below the bulb - 0.5 & 1. There is a mark etched around the upper suction tube- 11. Rubber tube connected to the upper suction tube aids in pipetting.

Blood is sucked upto 0.5 or 1 mark. diluting fluid is sucked up to 11 mark. white bead helps in identification and uniform mixing of blood with diluting fluid. Any clot in the lower delivery tube can be removed by a fuse wire.

Uses : It is used in 1. W.B.C. count 2. Sperm count

3. Hb pipette :

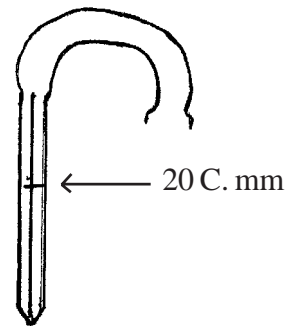

It is a pipette without bulb used in Hb estimation. The mark etched around the tube is 20 micro litres (0.02 ml) suction tube is attached at the top to aid in pipetting. Clot can be removed by a fuse wire.

Uses : This pipette is useful in determination of Hb by Sahli method and Cyanmethaemoglobin method.

4. E.S.R. Pipette :

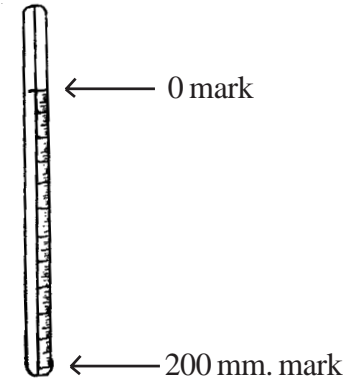

It is a graduated pipette with graduations from 0 to 200 mm.

Uses : It is used in E.S.R. determination by Westergren method.

Burettes:

Burettes are long cylindrical tubes of uniform diameter. Bottom of the burettes is narrow and provided with stopcock. They are available from 5 to 100 ml. There are two classes of burettes - Class A, Class B

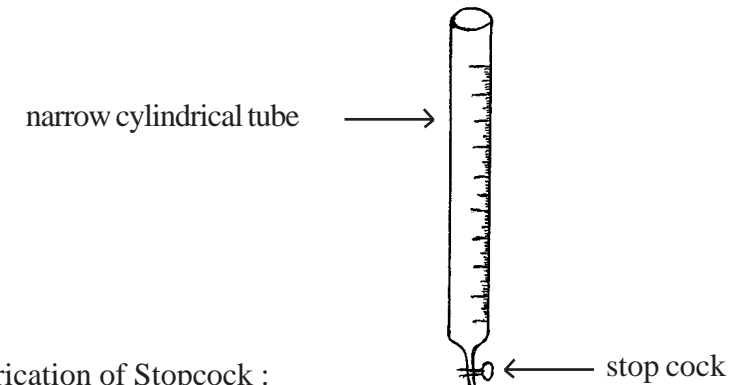

Lubrication of Stopcock :

For smooth functioning of stopcock without friction or freezing, lubrication with pure vaseline helps.

- Uses :
1. They are used in titrations.
 2. They are used in measurement and transfer of liquids.

Weight burettes : Weight burettes are used to measure the weight of the liquid, they transfer.

Measuring Cylinders :

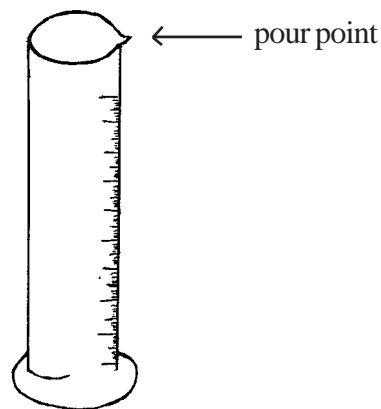

They are cylindrical in shape with flat bottom attached to provide base for resting vertically. They have pour point. There are graduations on the cylinder. They are available in capacities of 2 to 2000 ml. Since the area of surface is more than in volumetric flasks, measuring is less accurate with these cylinders.

General Apparatus :

Beakers :

Beakers are flat bottomed, broad based cylindrical vessels with a spout. They are available in capacities from 5 to 5000 ml. The most useful sizes are from 250 to 600 ml.

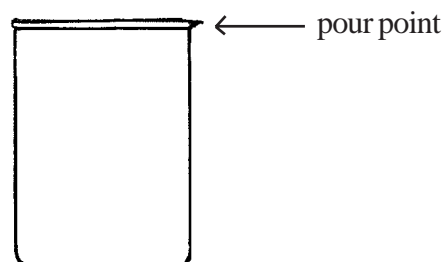

Advantages of the pour point are 1. Convenience in pouring 2. Providing vent for steam during boiling with the beaker covered by ordinary clock glass. 3. Providing convenience for protrusion of stirring rod when the beaker is covered.

Uses : 1. They are mainly useful for preparation of solutions.
2. They are useful in boiling the solutions.

- Flasks :
1. Conical Flasks
 2. Round bottom flasks
 3. Flat bottom flasks

Conical Flasks :

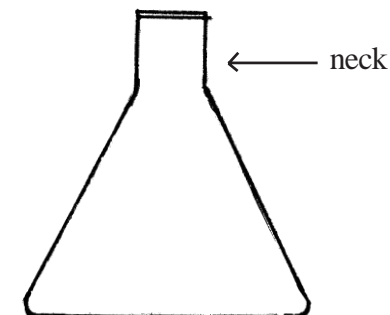

They are conical shaped with broad flat base. They are available in different sizes 200-500 ml. sizes have many applications.

Uses :

1. They are useful in conducting titrations.
2. They are useful in boiling solutions. Their conical shape minimises evaporation.

Round bottom flasks:

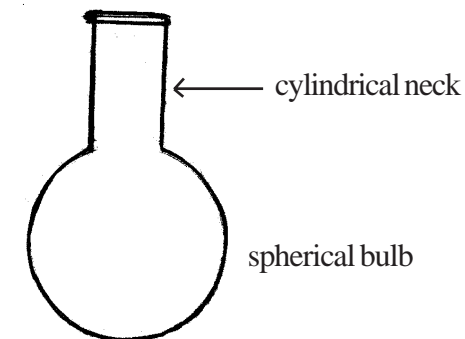

They have spherical bulb with a cylindrical neck. They can withstand high temperature.

- Uses :
1. They are used for making solutions.
 2. They are used for boiling the solutions.

- They are used in reflux condensations.
- They are used for distillation purposes.

Flat bottom flasks:

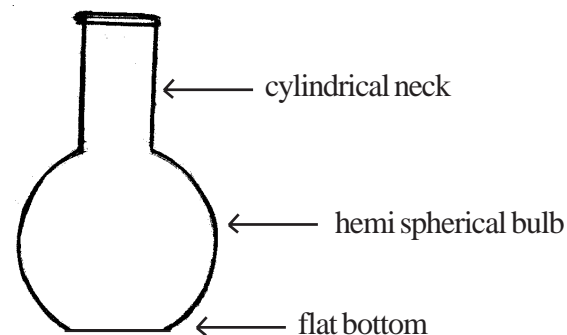

This is similar in shape to RBF except that it has flat bottom. It is mainly used for boiling the solutions, liquids etc.

Tubes : 1. Test tubes. 2. Centrifuge Tubes 3. Boiling tubes 4. Digestion tubes.

Test Tubes :

Test tubes are two types.

- Test tubes with rim
- Test tubes without rim.

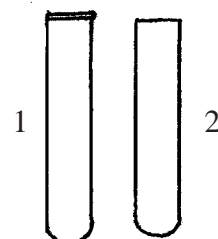

Test tubes with rim are used when reagent is heated on a flame directly. Rim provides grip for holding with a test tube holder.

They are available in different sizes. Commonly used test tubes are

- Small size
- Medium size
- Big size

- Small size test tubes have dimensions of 10 x 75 mm.

diameter length

They are used in qualitative testing procedures. They can also be used in place of centrifuge tubes.

- Medium size test tubes have dimensions of 15 x 125 mm. They find

application mainly in Biochemical estimations .

- Big size test tubes have dimensions of 18 x 150 mm. They find application in heating directly on flame.

Centrifuge tubes :

They are similar in shape to the test tubes except that bottom portion is conical.



Uses : They are useful for centrifugation and thus separation of solid from a liquid in which it is insoluble.

Boiling tubes :

They are bigger than test tubes. They have similar shape as test tubes. They are used for boiling small quantities of chemicals in qualitative testing procedures.

Digestion tube :

It is a narrow long test tube with slightly more than 50 ml. capacity. They have graduations 25 ml. and 50 ml. etched around.

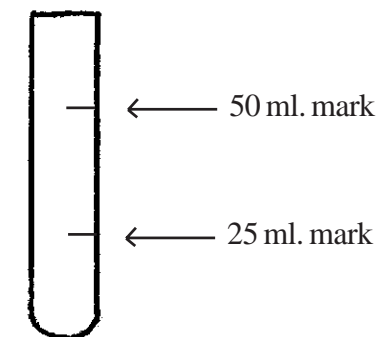

Uses : They are used for conversion of organic matter into inorganic matter. This conversion is affected in presence of digestion mixture.

Composition of digestion mixture :

It is composed of 50% sulphuric acid and 50% SeO_2

Syringes:

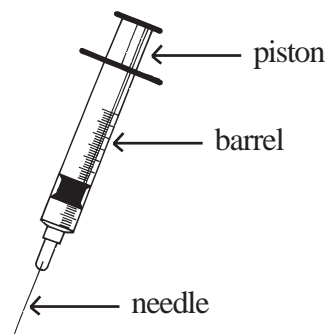

Syringes have three parts

1. Barrel
2. Piston
3. Needle

They are usually available in 2, 5, 10, 20 ml. capacities.

Uses :

1. They are used for collection of venous and arterial blood specimens.
2. They are useful for administration of drugs by parenteral route.
3. They are also useful for administration of drugs in kymographic experiments.

Funnels :

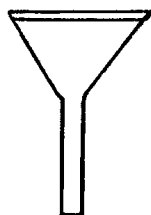

It has conical top attached to a narrow stem. They are available in different sizes. Common sizes are 50, 65, 75 ml. They are useful in

1. Transfer of liquids from one container to another container.
2. Transfer of finely divided solid from one container to another container
3. Separation of solid from liquid in which the solid is insoluble. This process is called as filtration. Filtration is setup using filter paper,

funnel, tripod stand and receiving container.

Separating funnels:

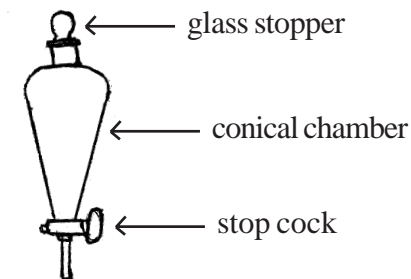

It contains a conical chamber with a narrow neck into which a glass stopper fits. Conical chamber is attached to a narrow stem which has a stopcock. Stopcock helps in controlled delivery of the liquid contents taken in the chamber.

Uses :

It is useful for separation of immiscible liquids. For separating immiscible liquids, stop cock is released until one liquid is delivered. Another liquid remains in the chamber which can be delivered into another container.

Condensers :

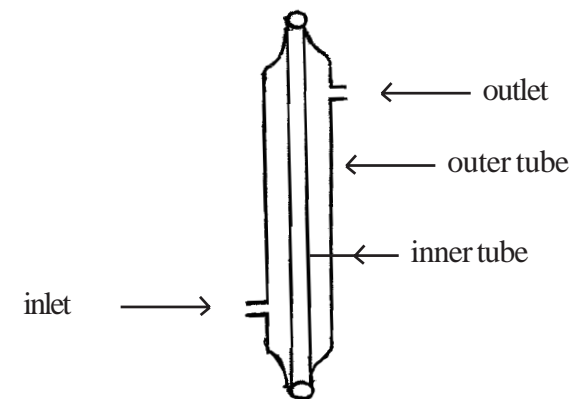

Condenser is a long narrow tube within a broad tube fused at the edges. It is arranged with inlet and outlet to the outer tube at opposite ends.

Uses :

They are useful in reflux condensation and distillation processes. It is used for refluxing by attaching its one end to an R.B.F, connecting the

condensor to water circulation and boiling the contents of the flask.

Dessicators :

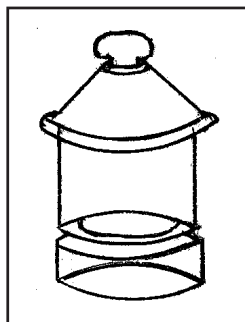

Dessicator is a glass container. Dessicant substances are charged into the shallow dish at the bottom of the container. Substances to be protected from atmospheric moisture are taken in crucibles, kept on a platform above the shallow dish and lid is closed.

Examples of dessicants are Silicagel, Alumina, Calcium Sulphate impregnated with cobalt salt. Cobalt salt provides self indicating character to the dessicant. When the dessicant is exhausted, colour changes from blue to pink. Regeneration of the dessicant can be done in a hot air oven.

Silica gel - 150-180°C

Activated alumina - 200-230°C

Vacuum Dessicator :

Drying is hastened by evacuating the dessicator. Evacuation can be accomplished by attaching to efficient water pump.

Bottles :

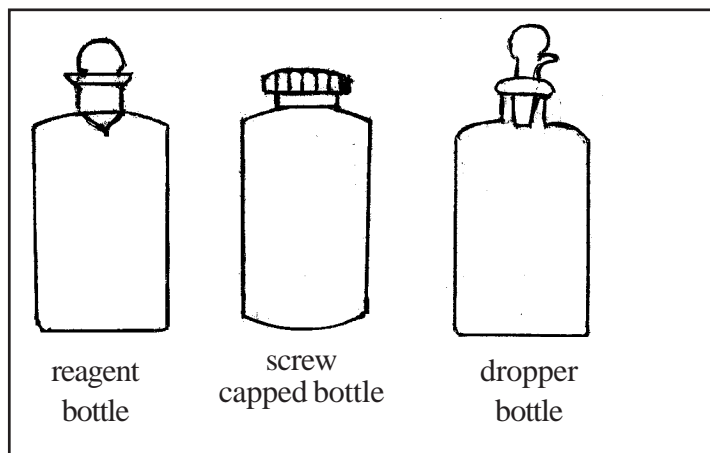

Reagent bottles : They are cylindrical shaped with narrow necks fitted with stoppers. They are available in different sizes. They are available in the range of 25-5000 ml. capacities.

Amber coloured bottles provide screening of u.v. light present in the sunlight and prevent entry into the bottle. Thus photo sensitive chemicals like silver nitrate can be stored in such bottles.

2. Screw capped bottles : They are available in 5-1000 ml. capacities. They are closed by screw caps made of metal or plastic.

Uses : They store hygroscopic substances.

3. Winchester quart bottles : They are cylindrical with narrow neck. They are fitted with glass stoppers. They are white or amber coloured available in 2 litres capacity.

Uses :

1. They are useful for storing reagents.
2. They are useful for collection of 24 hrs. urine specimen.
4. Drop bottles are bottles containing slotted glass stoppers. Slotted glass stoppers help in delivery of stains and indicators in form of drops.

Wash bottles :



Wash bottle is a flat bottom flask, that delivers distilled water or other liquid for use in the transfer and washing of precipitates. It is fitted with a rubber bung with three holes. By mouth, air can be pumped in to force the liquid through the other tube. Third tube will be open at both ends and should be closed by thumb while water is being blown out. It should be removed when the mouth pressure is released. It is used when organic

solvents have to be used for washing precipitates since polyethylene wash bottles cannot with stand organic solvents.

Stirring rods :



They are made from 3-5 mm diameter glass rods cut into suitable length. Both ends can be rounded in Bunsen flame. For use in a beaker, it should be of such length that it should come 2-3 cm. out beyond the spout.

Weighing bottles :

Bottles used for weighing chemicals are called as weighing bottles. They are used when substance is affected by atmosphere during weighing. External cap is preferable over internally fitting cap. Cap is made of glass, polyethylene or polycarbonate.

Chemical is placed in weighing bottle and weighed. Required quantity of substance is transferred into reaction vessel and then bottle reweighed. Difference gives the weight of the chemical used in the reaction process.

Watch Glass : Substances unaffected by atmosphere are weighed using watch glass.

Weighing funnel :



Weighing funnel is a funnel with scoop shaped end. After weighing on

a balance, narrow stem of the funnel is inserted into the neck of the flask and the contents of the funnel are washed into the flask with water / solvent from a wash bottle.

Cleaning, maintenance and storage of glassware:

All the glassware must be thoroughly clean and dry before using, otherwise results will be unreliable.

Tests for Cleanliness :

1. Fill the glass apparatus with distilled water.
2. With draw the water.
3. Observe for unbroken film of water.

Presence of unbroken film of water is indicative of thorough cleanliness. Collection of water in drops is indicative of presence of grease and dirt.

Aims of Cleaning :

1. Chemical cleanliness : Glassware should be free from all traces of cleaning agents and chemicals.
2. Freedom from particulate matter:
Glassware should be free of particles and fibres.
3. Freedom from pyrogens : Pyrogens are products of bacterial metabolism capable of increasing body temperature above normal. Glassware should be free from pyrogens also.
4. Freedom from Grease : Glassware should be free from grease.

Cleaning Agents :

There are four kinds of cleaning agents for glass ware.

1. Organic cleaning agents
2. Soap flakes and powders
3. Inorganic cleaning agents.
4. Chromic acid

i) Organic cleaning agents:

They may be strongly adsorbed on to glass. For this reason cationic detergents which are strongly anti bacterial cannot be used for bacteriological glassware . Use of excessive amounts of any detergent

is unwise.

ii) Soap flakes and powders :

Precipitation of Ca and Mg soaps takes place in hard water. Precipitated deposits on glass surface and impairs brilliance. Water softener such as sodium hexameta phosphate eliminates this problem.

iii) Inorganic cleaning agents :

Ex: Sodium metasilicate, sodium hexameta phosphate. Sodium hexameta phosphate is used alone or with soaps and gives brilliance to glassware. They are easily removed from the surface of the glassware.

iv) Chromic acid :

Chromic acid cleaning solution is made by dissolving 70 grams of sodium or potassium dichromate in 40 ml. of water using heat and then diluting to 1 litre with conc. sulphuric acid with constant stirring. Solution must never be added to acid. Gloves and rubber apron should be worn while preparing this solution.

v) Mixture of concentrated sulphuric acid and fuming nitric acid :

Mixture of concentrated sulphuric acid and fuming nitric acid is more efficient cleaning liquid. This may be used if the vessel is greasy and dirty. It must be handled with extreme caution.

vi) 10% KOH in methylated spirit :

100 g of KOH dissolved in 50 ml. of water and diluted to 1 litre with industrial methylated spirit is a very effective degreasing agent. It is claimed to be quicker than cleaning mixture.

vii) Teepol :

Teepol is relatively mild and inexpensive detergent. 10% solution in distilled water is laboratory stock solution. For cleaning a burette, 2 ml. of stock solution diluted with 40 ml. distilled water is poured into the burette, allowed to stand for 1/2 to 1 minute, the detergent run off, burette rinsed thrice with tap water, several times with distilled water. 25 ml. pipette may be cleaned in similar way. 1 ml. stock solution is diluted with 30 ml. distilled water for routine use.

Basic steps in cleaning :

General procedure: Different steps in cleaning are 1. Soaking 2. Brushing 3. Rinsing 4. Draining 5. Drying 6. Inspection 7. Storage.

1. Soaking : Apparatus are filled with and immersed in hot cleaning solution and left overnight.
2. Brushing: Hand brushing can be done. For bottles, brushing machine may be used.
3. Rinsing : Rinsing has to be done with tap water followed by rinsing with distilled water.
4. Draining : Water remaining on the surface of the glassware should be drained.
5. Drying: It can be done by keeping in a hot air oven. Temperature of drying is 60°C. Duration of drying is 15 minutes. Vent should be kept open during drying.
6. Inspection : Dried glassware should be inspected for presence of any dirt or fibres.
7. Storage : They should be stored in a cupboard until used.

II. Plasticware :

Plastic is widely employed for number of lab ware like Beakers, conical flasks, Bottles, centrifuge tubes, measuring cylinders, weighing bottles, stoppers, funnels, aspirators, spatulas, scoops etc. They are cheaper than glass articles. They are inert towards many chemicals. However certain limitations are there.

Different materials used for making plastic Labware are:

1. Polyethylene 2. Polypropylene 3. Polyvinyl chloride 4. Polystyrene 5. Poly amide (Nylon) 6. Polycarbonate 7. Teflon.
1. Poly ethylene : High density polyethylene is mostly used. It is a good barrier against moisture, relatively poor against oxygen and other gases. It is unaffected by strong acids and alkalies.
2. Polypropylene : It has good features of polyethylene. Poly propylene does

not undergo stress crack under any conditions. Lack of clarity is a drawback. Its biggest disadvantage is its brittleness at lower temperatures.

3. Polyvinylchloride : It is crystal clear. It must not be over heated. It starts degrading at 280^o F. PVC becomes yellow on exposure to UV light and heat.
4. Polystyrene : It is a rigid crystal clear plastic. It has low melting point 190^o F and cannot be used for high temperature applications. It is resistant to acids. It is not resistant to strong acids and alkalies. It is attacked by many chemicals.
5. Poly amide (Nylon) : Nylon can be autoclaved. It is extremely strong. It is quite difficult to destroy mechanically.
6. Poly Carbonate : Clear transparent containers can be made with it. It can be sterilised repeatedly. It is only moderately chemically resistant. It is resistant to dilute acids, oxidising or reducing agents, salts, oils, greases, aliphatic hydrocarbons and some alcohols. They are inexpensive and used in speciality containers.
7. Teflon : Teflon is of extremely inert character. It is used as liner, where heating with hydrofluoric acid or concentrated nitric acid is involved.

Cleaning, maintenance and storage of plastic articles :

Plastic articles require one or more of the following treatments.

1. Boiling in weak detergent. Concentration of detergent should be about 1%.
2. Boiling in dilute alkali. 1% sodium carbonate is enough.
3. Boiling in dilute acid. 1% HCl is enough.
4. Boiling in solution of sodium hexameta phosphate or EDTA.

15 minutes boiling in each case is enough. It should be followed by washing in running water. It should be followed by boiling in distilled water. Finally three more rinses in distilled water should be given.

5. After cleaning, they should be drained.
6. They can be air dried or dried in oven at 65^oC for 15 minutes with vent open. Oven should be used if the container material is thermostable enough.

7. After these steps, they can be used in different procedures.
8. After usage in different procedures, they have to be cleaned suitably.
9. Then they have to be kept in cup board and cleaned as above before using them again.

SUMMARY

Different glass and plastic apparatus are used in a laboratory for various purposes as measuring, transfer, filtration, storage etc. Glass used for lab purpose must be resistant to the action of chemicals. They also must withstand mechanical rigors during handling, effect of high temperatures and sudden changes in temperatures. Borosilicate glass is glass of choice for lab ware.

Laboratory glassware can be classified into 1) Graduated glassware 2) General glassware. Graduated glassware include graduated flasks, pipettes, burettes, weight burettes, measuring cylinders etc. General glassware include tubes, syringes, funnels etc. graduated glassware can be classified into 1) Class A apparatus which are used in works requiring highest accuracy 2) Class B apparatus which are used in routine work.

Glassware and plastic ware used in lab must be thoroughly clean and dry before use. Several cleaning agents are available. Different steps in cleaning are 1) Soaking 2) Brushing 3) Rinsing 4) Draining 5) Drying 6) Inspection 7) Storage.

Essay Questions

1. Give the composition of glass. Write about types of glass.
2. What are the types of laboratory glassware? Write about pipettes.
3. Mention the types of graduated apparatus. Write about graduated flasks.
4. Mention different general apparatus used in the lab. Write about a) Flasks b) Separating funnels.
5. What are the aims of cleaning? Classify cleaning agents. Write about the procedure of cleaning.

6. Write about plastic ware.

Short Questions

1. Write the composition of glass.
2. Mention types of glass.
3. Give the composition of borosilicate glass.
4. What is blooming?
5. Mention types of lab glassware.
6. Mention types of graduated apparatus on the basis of accuracy.
7. What are the types of graduated flasks?
8. Give the uses of a) Volumetric flasks b) Pipettes.
9. Mention types of pipettes.
10. How do you handle corrosive / toxic liquids?
11. What are different types of graduated pipettes?
12. What are serological pipettes?
13. Mention different blood pipettes and their uses.
14. What are weight burettes?
15. Write the uses of beaker.
16. What is Pour point?
17. Write the uses of conical flasks.
18. Differentiate between Round bottom flask and Flat bottom flask.
19. Write the construction of separating funnel.
20. Give the uses of funnel.
21. What is a condenser?
22. Mention types of dessicators.
23. Exemplify dessicants.

24. Mention different types of bottles.

25. What is a weighing bottle?

26. What is a weighing funnel?

27. Give examples of inorganic cleaning agents.

4. INSTRUMENTAL METHODS OF BIOCHEMICAL ANALYSIS

I. COLORIMETRY

Colorimetry : It is the method of analysis of determination of concentrations by visual comparison of colour intensities or by measurement of relative absorption.

Colorimeters : Colorimeters are instruments used in colorimetric analysis for determination of concentrations by visual comparison of colour intensities or by measurement of relative absorption.

Types of colorimetry: These are two types

1. Visual colorimetry
2. Photo electric colorimetry

1. Visual colorimetry : Visual colorimetry is the method of colorimetric analysis in which natural or artificial white light is generally used as light source and eye is used for colour comparison.

Ex: Determination of haemoglobin by Sahli method.

2. Photo electric colorimetry : Photo electric colorimetry is the method of colorimetric analysis in which light of narrow range of wavelength within visible range is used and eye is replaced by photocell for comparison of colour intensities.

Laws of colorimetry :

Lambert's Law :

This law is related with change of absorption of light with thickness of the medium (length of the light path in the medium). It was originally developed by Bouger and extended by Lambert. Hence it is also called as Lambert-Bouger's law.

Lambert-Bouger's law states that when monochromatic light passes through a transparent medium, intensity of emitted light decreases exponentially as the thickness of the absorbing medium increases arithmatically.

It is expressed by

$$\frac{I_e}{I_o} = e^{-Kt}$$

Where 'I_e' is intensity of emitted light, 'I_o' is intensity of incident light, 'e' is exponential, 'K' is constant and 't' is thickness of absorbing medium i.e. length of the light path through the medium.

Beer's Law :

Second law governing colorimetry was developed Beer and hence it is called as Beer's Law. It is related with change of absorption of light with concentration of coloured component.

Beer's law states that when monochromatic light passes through a transparent medium, intensity of emitted light decreases exponentially as the concentration of the coloured component in the medium increases arithmatically.

$$\frac{I_e}{I_o} = e^{-Kc} \quad \text{where 'c' is the concentration.}$$

Where I_e = Intensity of emitted light.
I_o = Intensity of incident light.
e = exponential
k = constant
c = concentration.

In the combined form these two laws are called as Beer-Lambert law.

$$\frac{I_e}{I_o} = e^{-Kct} \quad \text{or} \quad \log \frac{I_o}{I_e} = Kct$$

Where I_e = intensity of emitted light,
I_o = intensity of incident light
e = exponential
K = constant
c = concentration and
t = thickness (length of the light path through the absorbing medium).

Different instruments used for measurement of colour intensity. :

Instruments used in colorimetric analysis for measurement of colour intensity are called colorimeters.

Instruments used in visual colorimetry :

Instruments used in visual colorimetry are called as comparators or colorimeters.

Name of the visual method	Instrument /Apparatus used
1. Standard series method	1. Modified test tube rack 2. BDH Lovi bond Nessleriser mark 3 3. Lovibond 1000 comparator and Nessler tubes
2. Duplication method	Nessler tubes
3. Dilution method	Nessler tubes
4. Balancing method	1. Hehner cylinders 2. Duboscq colorimeter.

Instrument used in photo electric colorimetry : Photo electric colorimeter is the instrument for measurement of colour intensity of emitted light. In this instrument, eye is replaced by photo cell for comparison of colour intensities by measurement of relative absorption.

Visual colorimetric methods :

1) Color comparison by standard series method :

Test solution is taken in Nessler tube and diluted to mark. It is compared with a series of standard solutions containing the component. If exact matching is not obtained, further series of standard solutions within a narrow range are prepared and matching is done. Concentration of the test solution is that of the standard solution with which, colour matching takes place.

Ex: Concentrations in the series of standard solutions are 4%, 5%, 6%, 7%, 8% and colour matching is in between 5 and 6, another series in between 5 and 6 i.e. 5.2%, 5.4%, 5.6%, 5.8% concentrated solutions are made and matching done.

If exact matching takes place with 5.4%, concentration of the test solution is taken as 5.4% .

Different instruments available for determination in this method are

1. Modified test tube rack (for pH)
2. BDH Lovi bond Nessleriser mark-3
3. Lovi bond 1000 comparator.

Modified test tube rack : It is the simplest apparatus constructed with wood and used for comparison of colours in Nessler tubes. It is provided with glass reflector or mirror arranged to reflect light up through the tubes. Unknown and standard are placed adjacently and compared by looking vertically down through them.

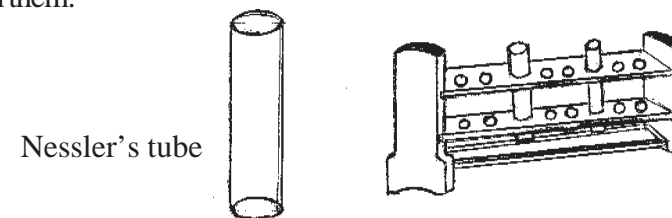

Colorimetric determination of pH can be done by this method employing series of standard buffer solutions and indicators. Test solutions are treated with indicators as done for standard solutions and pH of test is determined by comparing colour with colour of standard buffer after addition of indicator. If colour is in between two pH values, then another series between those two values can be obtained for comparison.

BDH Lovi bond Nessleriser Mark-3 : It is one of the simplest instruments employing permanent glass standards. It is used in number of determinations. It consists of a plastic case.

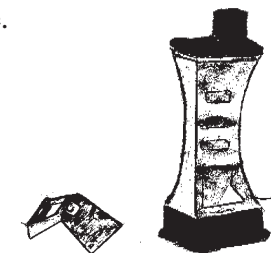

This plastic case holds two nessler tubes between a reflector and a detachable rotating disc.

It has nine apertures containing series of graded, permanent glass standards. Each disc contains a series of standards designed for one particular test. Discs for ammonia by nessler reagent, dissolved oxygen with indigo carmine, copper with dithio-oxamide, nitrate with phenol 2,3-disulphonic acid and chlorine with para amino N : N - diethyl aniline sulphate are available.

Lovi bond 1000 comparator : It is a device suitable for wide range of determinations such as pH determinations, concentrations of metal ions, detergents and organic compounds.

It also uses a series of permanent glass colour standards. Disc can revolve in the comparator. Each standard passes in front of aperture through which test solution can be observed. Value of the colour standard which matches with test solution appears in aperture.

2. Colour comparison by duplication method :

Test solution is taken in a nessler tube, colour developed with appropriate colour reagent and diluted up to mark. Standard solution is prepared in another nessler tube, and it is added to the reagent until colour matching takes place with test solution. It is less accurate than standard series method.

3. Dilution method :

Test and standard solution are taken in two nessler tubes of same size. Standard solution is diluted until colour matching takes place with test solution. It is the least accurate method.

4. Balancing method :

- a. Hehner cylinder
- b. Duboscq colorimeter

a) Hehner cylinder :



They are pair of cylinders employed in matching colours by balancing method. Each cylinder has a glass stop cock about 2.5 cm. from the bottom. Through the stop cocks liquid can be withdrawn until colours in the two cylinders match on observing vertically. They are graduated in ml.s and have capacity of approximately 100 ml.

b) Duboscq Colorimeter :

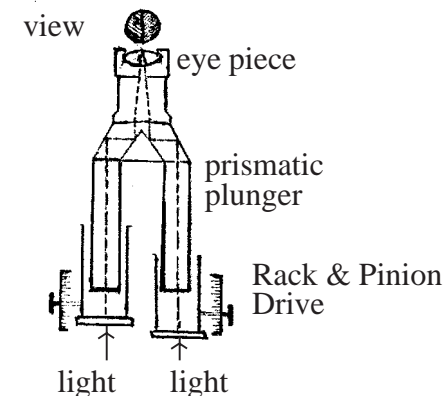

It is used for colour comparison by balancing method. It is plunger type instrument. It consists of two tubes. Test solution is taken in one tube and standard solution is taken in another tube. Light beams enter the tubes and presented to an eye piece where they are viewed in juxtaposition as semi circles. It is possible to change the length of the light path through each of the solution by means of rack and pinion movement to get a correct matching. When correct matching takes place, dividing line between the two semi circles disappears.

$$c_1 l_1 = c_2 l_2 \quad \text{Let } c_1 = \text{Concentration of test solution}$$

$$l_1 = \text{Length of light path in test solution}$$

$$\text{Let } c_2 = \text{Concentration of standard solution.}$$

$$l_2 = \text{Length of light path in test solution.}$$

$$\text{Then } c_1 = \frac{c_2 l_2}{l_1}$$

Photo Electric Colorimeter :

Visual colorimetric methods have various disadvantages. Colour matching

by eye is not perfect. Eye is not as perfect as photocell. Photo electric colorimeters measure the intensity of the emitted light after absorption of the incident light has taken place while passing through the solution. Hence they are called as photo electric photometers or absorptiometers.

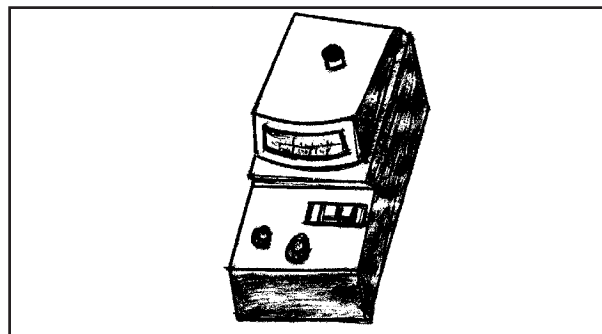

Photo electric colorimeter uses light of wave length in the visible range i.e. 380-760 millimicrons approximately as incident light. Spectro photometer uses ultra violet, visible and infrared spectra.

Principle :

When monochromatic light passes through a solution, some part of the light is absorbed by the solution and intensity of emitted light will be less than intensity of incident light. This is in accordance with Beer-Lambert's law as per which intensity of emitted light decreases exponentially as 1. the thickness of the absorbing medium 2. concentration of the coloured component in the medium increase arithmatically.

Construction :

Various parts of a colorimeter are :

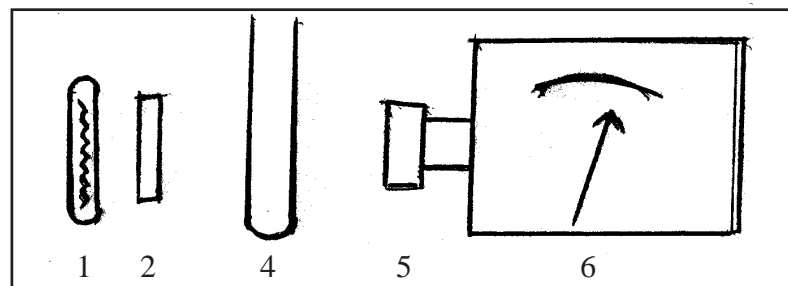

1. Light source

- 2. Wave length selector
- 3. Lenses
- 4. Cuvette
- 5. Photo cell
- 6. Galvanometer

1. Light source : Requirements -

- a. It must generate beam with sufficient power.
- b. It must be stable
- c. It should produce continuous radiation.

Most common source of radiation in the visible range is incandescent tungsten filament lamp. It emits light in the range of 400 to 760 milli microns wave length.

2. Wave length selector :

Reason for selection of particular wave length range in quantitative determinations is

- a. Employing the radiation of wave length, which is absorbed to the maximum extent by the component to be determined as it enhances sensitivity of determination of the component.
- b. Other substances present in the specimen / solution which absorb radiation of other wave length region are less likely to interfere.

In the case of a photometer, a filter is used as wave length selector. Choice of a filter for any particular component is to give maximum absorption for unit change in concentration.

Filters are of two types.

- i) Absorption filters
- ii) Interference filters

i) Absorption filters : These emit desired wave length by absorbing certain portions of spectra. Most common types of absorption filters are

- a. Filters made of coloured glass

b. Coloured gelatin films sandwiched between glass plates.

Various filters supplied by manufactures are

- a. No. 601 - spectrum violet (380-470 nm)
- b. No. 602 - Blue spectrum (440-490 nm)
- c. No. 603 - Blue-Green spectrum (470-520 nm)
- d. No. 604 - Green spectrum (500-540 nm)
- e. No. 605 - Yellow-Green spectrum (530-570 nm)
- f. No. 606 - Yellow spectrum (560-610 nm)
- g. No. 607 - Orange spectrum (570nm with absorption increasing 600 nm onwards)
- h. No. 608 - Red spectrum (620 nm into infrared)

Interference filters :They rely on optical interference to emit narrow range of radiation. An interference filter is transparent CaF_2 or MgF_2 solution between two semi transparent metal films (usually silver) coated on inner side surfaces of two glass plates.

4. Cuvettes : Cuvette is a cell for containing the solution, optical density of which is to be determined. Cuvette should be made of such a material that it is unable to absorb the selected range of radiation. For visible range, a cuvette should be of glass, silica or plastic. Cuvettes are round tube type (cylindrical) or rectangular or cylindrical with flat end.

Lenses : Simple lenses are used to focus light beams.

5. Photo cell : It is the detector of intensity of light emitted from cuvette. It is also called as detector or photo detector. It produces a signal proportionate to the intensity of light emitted from the cuvette and incident on it. Thus they convert light energy into electrical energy.

There are three types of photocells used in photo electric colorimeters. They are

- 1. Barrier layer cells
- 2. Photo emissive tubes (vacuum tubes)
- 3. Photo multiplier tubes.

6. Galvanometer : A Galvanometer is used to detect and measure electrical current produced by photo detectors. It contains a coil in between the poles of a permanent magnet. When electrical current passes through it, magnetic field sets up 90° away from permanent magnet's poles causing the coil twisted. Reading will be in the form of optical density or percent transmission or mg %.

Types of photo electric colorimeters on the basis of photo cell employed:

On the basis of photocells used, they can be classed into

- 1. Photometers employing barrier layer cells (voltaic cells)
- 2. Photometers employing vacuum tubes
- 3. Photometers employing photomultiplier tubes

Types of photo electric colorimeters based on number of beams.

They are classed as

- 1. Single beam instruments : They contain one optical path.
- 2. Double beam instruments : They contain two light beams.

Types of photo electric colorimeters on the basis of number of photo cells

They are classed as

- 1. Single cell instruments : They contain one photo cell.
- 2. Double cell instruments : They contain two photo cells.

Operation of single cell photometer:

- 1. Take similarly treated test, standard and blank solutions.
- 2. Switch on the power supply to the colorimeter and then light source.
- 3. Set the colorimeter to zero optical density or 100% transmittance using blank at wave length specified to the determination.
- 4. Determine the optical densities of similarly treated test and standard solutions.
- 5. Calculate the concentration of unknown by using the formula

Concentration of unknown =

$$\frac{\text{Optical density of test}}{\text{Optical density of standard}} \times \text{concentration of standard}$$

6. Set the colorimeter to zero optical density with distilled water and switch off the power supply.

Basic steps involved in a colorimetric estimation :

Basic steps involved in a colorimetric estimation are :

1. Separation of interfering substances
2. Colour development
3. Determination of optical densities
4. Calculation

1. Separation of interfering substances :

In a specimen, along with the component to be determined, other components also will be present. They may also absorb the incident radiation and if so, true concentration of the component in the specimen cannot be got. Thus, such substances which absorb the radiation at wave length (specific to the component to be determined) along with the component to be determined are said to be interfering in the estimation and leading to false results.

To determine the true concentration of the component, substances interfering in the absorption of the radiation at the particular wave length have to be eliminated. for ex: Deproteinisation step in blood sugar determination by Folin & Wu method, blood urea by diacetyl monoxime method and serum creatinine by alkaline picrate method.

2. Colour development :

Colorimetric analysis is determination of concentration based on colour intensity of the component to be determined. Relation between the concentration and colour intensity of the component is direct. When the component is not originally coloured, colour intensity based analysis is not possible. In such cases, colour development has to be done using appropriate reagent. The appropriate reagent which reacts with the substance being determined and gives a coloured complex is called as colour developer. Colour developed will be proportionate to the concentration of the substance.

Ex. 1. In serum creatinine determination by alkaline picrate method, picric acid is the colour developer. It gives reddish yellow coloured complex with

creatinine in the presence of alkaline medium.

Ex. 2. In serum uric acid determination by Henry-Caraway method, phospho tungstic acid is the colour developer. It reacts with uric acid in alkaline medium to form a blue coloured complex.

3. Determination of optical densities :

Optical densities of similarly treated test and standard have to be determined using photoelectric colorimeter. Prior to this, instrument has to be set to zero optical density or 100% transmission at the wave length using similarly treated blank. Wave length selected shall be such that radiation of that wave length will be absorbed to the maximum extent by the component being determined. This will enhance sensitivity of concentration determination.

4. Calculation :

Concentration of component in the specimen can be calculated by using the optical densities of test and standard. It can be calculated arithmetically using the formula.

$$\text{Concentration of unknown} = \frac{\text{optical density of unknown}}{\text{optical density of standard}} \times \text{concentration of standard}$$

It can also be got from the graph. Graph has to be prepared plotting optical densities / % transmissions of different standards on Y axis and their concentrations on X axis. For this, different standard solutions have to be similarly treated as test solution and their optical densities have to be determined.

Care and maintenance :

1. Keep a plastic cover on the photo electric colorimeter when not in use.
2. Keep the power supply and light source switched off, when not in use.
3. Put the proper filter and cuvette filled with distilled water in their positions before putting on the colorimeter.
4. Check the sensitivity of galvanometer occasionally using a standard dichromate solution.

- Maintain the instrument clean.
- Do not keep the instrument nearer to vibrating instruments and heating apparatus etc.

Applications :

1. Photo electric colorimetry is the most important tool in a biochemical laboratory. It is useful in determination of components of biological fluids such as blood / serum / plasma, urine, sputum, cerebrospinal fluid etc.

Ex.: Blood sugar, serum cholesterol, blood urea, serum uric acid, serum creatinine etc.

2. It is useful in pharmaceutical analysis, research and clinical studies.

3. Photometric titrations have been useful in locating end point in a titration. These titrations are called as photometric titrations. Photometric titrations have been used in several reactions.

Ex: Amino acids, potassium permanganate, potassium dichromate, iodine etc. Photometric titrations are excellent for weak acids. Strong acids cannot be titrated by this way.

II. Spectro Photometry :

Spectrophotometry : Spectro photometry is method of analysis in ultra violet range, visible range and infrared range.

Spectro photometers are the instruments used in spectro photometry. They are more precise than photo electric colorimeters. There are certain disadvantages of photoelectric colorimeters.

- True absorption curve cannot be obtained.
- Beer's law is not followed. Absorptivity changes from colorimeter to colorimeter.
- Photo electric colorimeters work in the visible range only.

Electro magnetic radiation : Electro magnetic radiation can be conveniently divided into

- X-rays - 10^{-1} to 10^1 A⁰
- Ultraviolet range - 10 - 400 nm.
- Visible range - 400 - 800 nm.

- Infrared 0.8 - 1,000 microns
- Microwaves 0.1 - 100 cms.
- Radio waves 1 - 100 mts.

Ultraviolet region : It is region of the electromagnetic spectrum below 400 millimicrons wavelength. It can be divided into

- Far ultraviolet region (extending from 10-200 millimicrons)
- Near ultraviolet region (extending from 200-400millimicrons)

Visible region : It is the region of electro magnetic spectrum between about 400 millimicrons to 800 millimicrons wavelength.

Infrared region : It is the region of electromagnetic spectrum extending above 800 millimicrons wavelength. Infrared region can be divided into three regions.

- Near infrared region.
- Mid infrared region.
- Far infrared region

Principle : Beer - Lambert's law is followed. Measurement of absorptivity of the radiation by the component to be determined forms the basis of spectrometry. Colorimetry covers only visible range whereas spectrometry covers ultraviolet, visible and infrared ranges of electromagnetic spectrum.

Parts of spectro photometer :

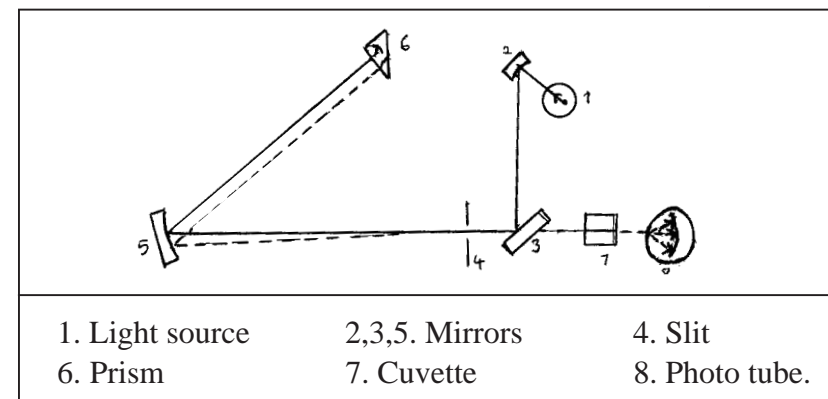

- Light source
- Monochromators and slits

3. Associated optics

4. Cuvettes / sample holders

5. Photocells

6. Galvanometer

1. Light source : For work in the ultra violet region, ordinary tungsten lamp is not useful. High pressure hydrogen or deuterium discharge lamps are useful. They are useful from 160-360 millimicrons. In infrared spectroscopy, Nernst Glower and Globar are the most common sources of radiation. Nichrome wire heated by passage of current and Rhodium wire heater sealed in a cylinder are also employed. Tungsten lamp is also useful for near infrared.

2. Monochromators and slits :

Monochromators for radiation of ultra violet range require quartz or silica prisms or gratings. For infrared range also prism or grating type of monochromators are employed. Quartz is used for 0.8 to 3 microns range. Crystalline sodium chloride is the prism material between 5 and 15 microns range. Crystalline potassium bromide and cerium bromide are satisfactory for far infrared region (15-40 microns). Lithium fluoride provides prism materials in the near infrared region (1-5 microns)

Slits : Two slits are usually there. They are entrance slit and exit slit. Desired wave length may be selected by adjustment of exit slit.

3. Associated optics :

Simple lenses are used to focus light beams. In special spectro photometers mirrors coated with magnesium fluoride are employed to reduce light scattering.

4. Cuvettes / sample holders :

Cuvettes in ultra violet region are made of quartz or fused silica for region below 50 millimicrons. Silicate glasses between 50 millimicrons and 2 microns. Best cells have windows in order to minimise reflection effect.

5. Photo Cells :

Photo emissive tubes or photo multiplier tubes are used. Photo multiplier tube is the most widely employed detector in untra violet range. Detectors suitable for infrared range are of two types.

1. Thermal detectors

2. Photo detectors

Thermo couple is the most widely used infrared detector. Bolometer and Thermister also have been used. Golay cell is also widely used. successful infrared detectors are made from crystals as triglycine sulphate, barium titanate and lithium niobate. Photo detectors for infrared take form of small wafe of semiconducting material such as lead sulphide, indium antimonide. Lead sulphide can be used in near infrared at room temperature.

6. Instrument for measurement of response of detector :

They measure the response of the photocells. Electrical current is measured by Galvanometer.

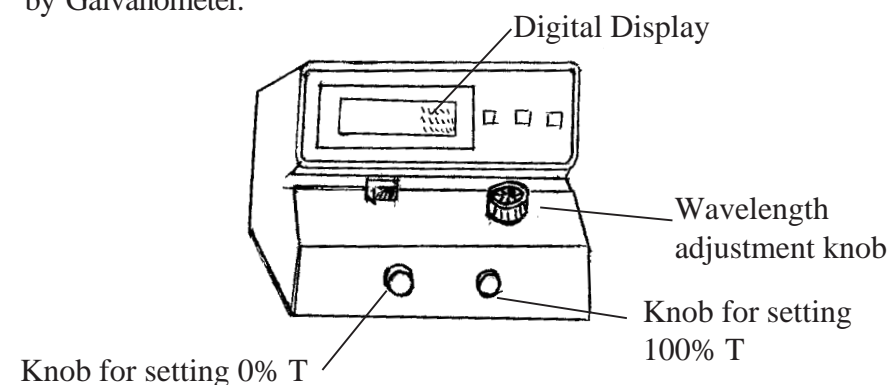

Types of Spectrophotometers :

They can be divided into two groups.

1. Manual spectrophotometers
2. Recording spectro photometers

Manual spectrophotometers consist of

1. Wave length controll knob.
2. Adjustable mechanical slit.
3. Dark curent control knob with detector in darkness (for setting 0% transmittance reading)
4. Sensitivity controll knob (for setting 100% transmittance reading)
5. Balance Potentio meter

Recording spectrophotometers consist of

1. wavelength control knob
2. Adjustable mechanical slit
3. Dark current control knob
4. Sensitivity control knob
5. Switch to start, stop and reverse scan drive
6. Scanning speed selection control.
7. Paper speed control, pen control, range control etc.

Types of Spectrophotometers on the basis of number of optical paths:

1. Single beam spectrophotometers consisting of one optical path.
2. Double beam spectrophotometers consisting of two optical paths.

Solvents used in UV spectrophotometry :

Acetone, Benzene, Pyridine, Water, Acetic acid, Butanol, Toluene, Xylene etc.

Care and maintenance :

1. Place a plastic cover, when not in use.
2. Check the sensitivity occasionally.
3. Maintain the instrument clean.
4. Do not keep the instrument nearer to vibrating and heating instruments.

Applications :

1. Visible spectrophotometry has wide range of applications. Ex: Determination of Salicylic acid, urea, glycine etc.
2. UV spectrophotometry finds applications in identification of Hydrocarbons, vitamins, steroids, heterocyclics and conjugated aliphatics. UV spectrophotometry is also used for identification of degradation products and for testing the purity in biological and pharmaceutical research.
3. U.V. spectrophotometry is used for determination of unsaturated hydrocarbons, alcohols, ethers and amines.
4. Steroids, enzymes and many other substances can be determined by UV spectrophotometry.
5. Vitamin A can be assayed by measuring the absorbance at 334 nm.
6. Aspirin extracted from acidified aqueous solution with chloroform can

be measured at 277 nm.

7. Caffeine and Phenacetin can be determined at 25 and 275 nm.
8. U.V. spectrophotometry is applicable for determination of inorganic substances such as Lead in bone ash, Mg, As, Br, Ca, Cl_2 , Cl^- , CO, Cu, Fe, I^- , K etc.
9. U.V. and visible spectrophotometry prove useful in elucidation of structures of organic compounds.
10. U.V. spectrophotometry is useful in determination of tetracycline at 220, 268 and 355 nm.
11. Spectrophotometry can also be useful in deciding constitution of compounds, confirming constitution of compounds, measuring concentrations of solutions.
12. H^+ ion concentration can be determined by using spectrophotometry with suitable indicators.
13. Spectrophotometry is also used in locating equivalence point in titrations. These titrations are called as spectrophotometric titrations.
14. I.R. spectrophotometry is useful in qualitative analysis of natural products and when combined with gas chromatography, it is useful for identification of compounds separated by that technique.
15. A quantitative determination can be carried by comparison of absorbance of unknown at suitable wavelength with that of standard in I.R. spectrophotometry.
16. Structural diagnosis is the most important application of I.R. spectrophotometry and it is thus of great value in checking the synthesis as well as elucidating unknown structures of natural products.

SUMMARY

Colorimetry and Spectrophotometry are important methods of instrumental analysis in any biochemical work.

Colorimeters are used in colorimetry. Colorimetry is two types 1) Visual colorimetry 2) Photo Electric Colorimetry. Colorimetry is based on Beer-Lambert's Law. Spectrophotometry is more accurate than colorimetry. It is a method of analysis with light source in 1) uv-range 2) Visible range 3) I.R. range.

Essay Questions

1. Classify colorimetric procedures. Mention the colorimeters used in various colorimetric procedures.
2. Write about Beer - Lambert's Law.
3. Classify visual colorimetric procedures. Mention different visual colorimeters. Write about Dubosq colorimeter in detail.
4. Give the principle, construction, operation and care and maintenance and applications of photo electric colorimeters.
5. Classify photo electric colorimeters.
6. Write about the steps involved in photo electric colorimetric procedure.
7. Give the principle, construction, care and maintenance of spectro photometer.
8. Give the applications of spectrophotometry.

Short answer questions

1. Define colorimetry.
2. Mention the types of colorimetry.
3. Differentiate between visual and photo electric colorimetry.
4. Give Beer-Lambert's Law.
5. Write Beer's Law.
6. Write Lambert's Law.
7. What are the visual colorimetric procedures employing nessler tubes?
8. Mention the instruments used in standard series method.
9. What is Hehner cylinder?
10. Write the disadvantage of visual colorimetric procedures.
11. What is the most common source of radiation in photoelectric colorimeter? Give its wave length range.
12. What is the purpose of filter in a photo electric colorimeter? Mention the types of filters.
13. Mention the materials of construction of Cuvette used in photo electric colorimetry.
14. What are different types of photocells?

15. Write the applicatonn of Photo Electric Colorimeter in Biochemical laboratory.
16. What are the disadvantages of photoelectric colorimeter?
17. Give the division of U.V. range.
18. Divide I.R. region.
19. What are different parts of Spectrophotometer?
20. Mention the prism materials in Spectrophotometry.

5. BASIC LAB OPERATIONS

Lab Technician should be well verse in basic lab operations like I) Separation of solids from liquids a) Centrifugation b) Filtration using funnel II) Weighing III) Evaporation IV) Distillation V) Refluxing VI) Drying different salts and dessication.

I. Separation of Solids from Liquids :

a. Centrifugation :

Centrifuges are used for 1. Separation of solids from liquids in which solid is insoluble. 2. Separation of immiscible liquids. In a biochemical laboratory, they are useful in separation of cells from plasma, clotted blood from serum and precipitate from liquid.

Principle of Centrifuges:

Centrifuges work on the principle of centrifugal force to separate insoluble solid from a liquid. Centrifugal force needed to affect the separation process is provided by mechanical energy.

Centrifugal force:

In a circle, force acting away from the centre of the circle is called as centrifugal force where as force acting towards the centre of the circle is centripetal force.

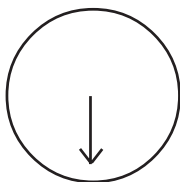

centrifugal force

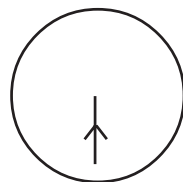

centripetal force

Types of Centrifuges :

1. Hand centrifuge
2. Electrical centrifuge
3. High speed centrifuge
4. Ultra centrifuge
5. Refrigerated centrifuge

1. Hand Centrifuge : Hand centrifuge is a device operated by hand which can give upto 2,000 to 2,500 R.P.M.

Principle : 1. It works on the principle of centrifugal force to separate insoluble solid from a liquid.

2. Mechanical energy which provides the centrifugal force is got by hand.

Construction : Hand centrifuge consists of

1. Bucket assembly consisting of two or four aluminium or plastic buckets for holding the tubes
2. Central pillar
3. Handle to cause revolutions

Operation :

1. Fit the centrifuge to any table top.
2. Place the tube / tubes to be centrifuged in the buckets.
3. Rotate the handle to cause revolutions.

Precautions:

1. Tubes must be balanced. Otherwise tubes may be broken.
2. Increase or decrease of speed should be gradually done.

Maintenance :

Parts of the hand centrifuge may be disassembled after routine work in a day and kept in a cupboard.

Applications and uses :

They are mainly useful in qualitative tests to separate precipitate formed in a chemical reaction from a liquid. They find application in a chemistry laboratory, Pharmacy laboratory, Medical laboratory and a Biochemical laboratory.

2. Electrical centrifuge :

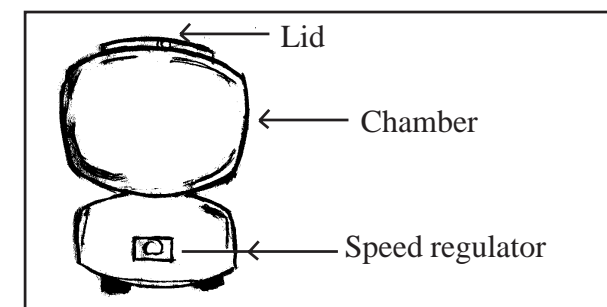

Electrical centrifuge is a device operated by an electric motor which can give up to 4,000 RPM. Two types of centrifuges used in laboratory are 1. Swing out head type 2. Angle head type.

Principle :

1. It works on the principle of centrifugal force to affect separation of insoluble solid from a liquid.
2. Mechanical energy which provides the centrifugal force is got by electrically operated motor.

Construction :

Electrical centrifuge consists of

1. Rotor with tubes

2. Motor
3. Chamber to enclose the internal parts.
4. Lid on the top to close the chamber during centrifugation.
5. A multistage speed regulator to obtain desired speed
6. Timer
7. Tachometer to read the speed
8. Graphite brushes to provide electrical contact to the rotor.
9. Power switch.

Operation :

1. Place the tubes to be centrifugated in the buckets following balancing of the tubes.
2. Close the lid.
3. Put on the power switch.
4. Increase the speed gradually with speed regulator.
5. After centrifugation is over, decrease the speed gradually.
6. Put off the power switch.
7. Open the lid and remove the tubes.

Precautions :

1. Keep the centrifuge on a firm base.
2. Balance the tubes properly. Otherwise tubes may be broken.
3. Increase or decrease speed gradually.
4. Keep the lid closed during centrifugation.
5. Do not open the lid until the rotor comes to a stop.

Maintenance :

1. Keep the chamber clean.
2. Keep the plastic cover on the centrifuge when it is not in use.
3. The graphite piece should be replaced by a new one, if it wears out.
4. Check the electrical connections at regular intervals of time.
5. Lubricate the moving parts at regular intervals of time.

Uses and applications:

It is useful in

1. Separation of insoluble solid from a liquid.
2. Separation of immiscible liquids.

In a medical laboratory, it has different applications. Some of them are-

1. Separation of serum from clotted blood.
2. Separation of plasma from cells.
3. Separation of urinary sediment for preparation for microscopic examination.
4. Separation of precipitate or supernatant as required.

Ex:a) Separation of precipitate after addition of 10% Barium chloride solution in Fouchet's test.

b) Supernatant liquid is required for preparation of protein free blood filtrate, which is required when interference of proteins is needed to be eliminated as in the case of blood sugar determination by Folin and Wu method.

It also finds applications in Pharmacy laboratory and chemistry laboratory.

3. High speed centrifuge:

High speed centrifuge is an electrical centrifuge with capacity of up to 20,000 RPM. High speed can be achieved by angle head rotor units due to very low friction. Maximum tube size is 200 ml. It has applications in Medical and Pharmaceutical research.

4. Ultra Centrifuge : Ultra centrifuge is an electrical centrifuge with a capacity of upto 1,00,000 RPM.

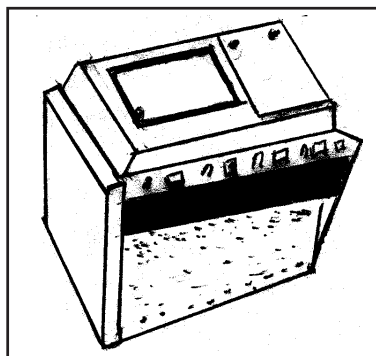

5. Refrigerated centrifuge : Refrigerated centrifuge is provided with refrigeration in the main cabinet. Refrigeration is achieved by means of a compressor, located in the main cabinet. Temperature control is provided by thermostat. Temperature regulator is dial type of regulator. Temperature is indicated by thermometer.

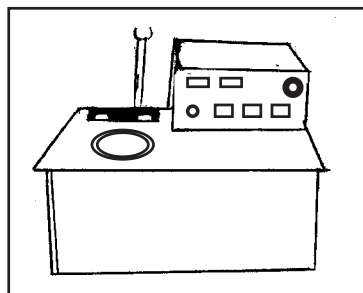

It finds application in biologicals such as vaccines and blood products.

b. Filtration using Funnel

Filtration can be done most simply using filter funnel and filter paper. Filter funnel for this purpose should have an angle close to 60°. Stem should be about 15 cm long. Filter paper is the filter medium. Liquid and solid insoluble in this liquid mixed together is called slurry. Funnel provides support for filter medium. Solid part separated after filtration is called residue. Clear liquid collected after

filtration is called filtrate.

Process of filtration can be set up as follows. A tripod stand should be placed over a working bench. Funnel should be placed over tripod stand with its stem into receptacle (generally a beaker or a conical flask). Filter paper should be folded. Folded filter paper should be placed over the funnel. Slurry should be poured into the fluted filter paper using glass rod.

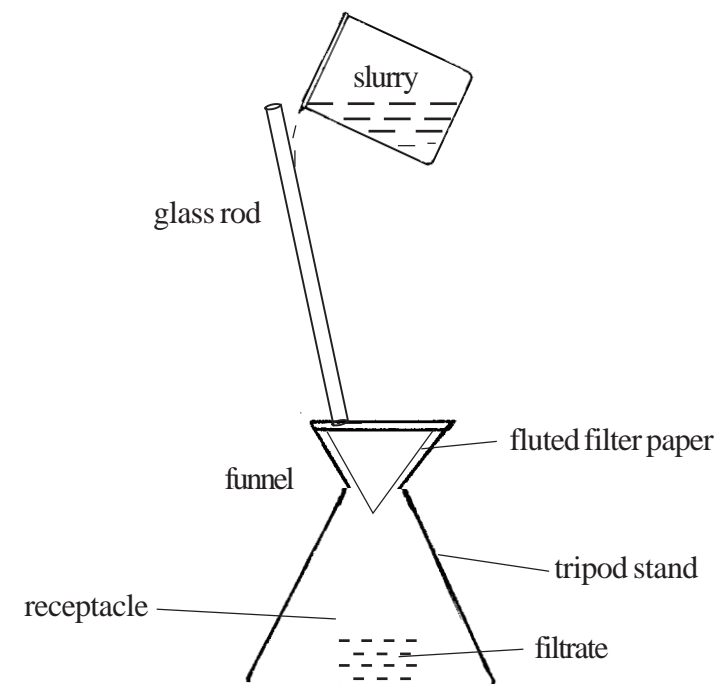

Filtration setup using filter funnel

Large quantities of material can be filtered using Buchner funnel.

II) Weighing : Different types balances used, care and maintenance.

Weighing is an important activity in a laboratory. Weighing of chemicals is required for preparation of reagents, standard solutions etc. Weighing for qualitative analysis can be approximate. Weighing for quantitative determinations must be accurate. Weighing requires balances. Accurate weighing can be done with analytical balances. Balance is one of the most important tool of an analytical chemist.

Balances : Balance is a device to measure mass. Mass is an intrinsic property of matter which is constant through out universe. Weight is the force with which a body is attracted by gravitational force.

Different types of Balances :

1. Simple balance.
2. Two knife single pan balance.
3. Top loading balance.
4. Electronic balance
5. Miscellaneous
 - a) Torsion suspension balance
 - b) Electro balance
 - c) Torsion balance

Classification of balances according to capacity

1. Analytical balances:
 - Capacity : 150 to 200g.
 - accuracy upto 0.1 mg.
2. Semimicro balances :
 - Capacity : 75 to 100g.
 - accuracy upto 0.01 mg.
3. Micro balances :
 - Capacity : 10 to 30g.

accuracy upto 0.001 mg.

Requirements of a good balance :

1. Good reproducibility and precision

Good reproducibility and precision depend on -

- a) skill of the operator
- b) Environment free from vibrations, protected from air currents and corrosive fumes.
- c) Construction requirements such as arms of equal length, rigid beam etc.

2. Stability : Beam must return to horizontal position after swinging.

3. Balance must be sensitive i.e. 0.1 mg. should be readily detectable.

Simple Balance : It is also called as analytical balance, analytical 2 pan balance, chemical 2 pan balance.

Principle : Simple balance works on balancing of the forces with which the bodies in the two pans are attracted by gravity. Ratio of the forces with which the bodies in the two pans are attracted by gravity is equal to the ratio of the two masses. $F_1/F_2 = M_1/M_2$. Where F_1 and F_2 are the forces with which bodies in the first and second pan are attracted by gravity and M_1 and M_2 are masses of the bodies in first and second pans.

Construction :

Components of the simple balance:

1. Brass beam with an agate knife edge in the centre and two other knife edges at the two ends. Beam carries a scale divided into 100 equal parts. Beam is provided with adjusting screws at the ends to compensate slight inequalities between two sides
2. Tall hollow pillar
3. Board supported on levelling screws
4. Glass case with two glass doors on both sides
5. Two equal stirrups supported by the knife edges at the two ends of the brass beam to suspend the pans

6. Two equal scale pans suspended from the stirrups
7. Long thin metallic pointer fixed to the centre of the beam
8. Graduated ivory scale fixed near the lower end of the pillar
9. A support in the hollow pillar which is movable slightly up or down by means of a lever handle
10. A lever handle in front of the board with which balance can be set into action or arrest
11. Special hook and carriage arrangement for moving the rider.

Operation :

- Requirements :
1. Simple Balance
 2. Box of standard weights and a rider
 3. Forceps
 4. Body or sample to be weighed

Weight Box : Ordinary set of analytical weights

Weights in grams : 100, 50, 30, 20, 10, 5, 3, 2, 1.

Fractional weight box: Weights in milligrams.

Rider : For adjustments of weight of less than 10 mg., rider is used. Rider consists of a small piece of gold or platinum wire. It is bent into such a shape that it will rest on the scale. Movement of the rides is carried out by a special hook and carriage attachment. Adjustments below 10 mg. can be done by moving the rider along the along the scale, which is divided into 100 equal parts.

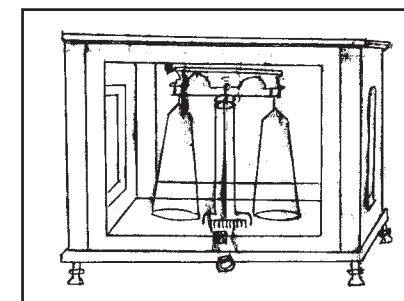

Procedure:

1. Sit opposite to the centre of balance.

2. Clean the pans with camel hair brush.
3. Check the balance for equal sliding of the pointer on both sides by operating the handle lever.
4. Arrest the movements of the beam by operating the handle lever.
5. Place the body / sample to be weighed on the left pan and weights on the right pan.
6. Set the balance to movement and check for equal movement of pointer on the both sides of ivory scale. Arrest the movements of beam every time, a weight is removed or added to the pan.
7. Move the rider along the scale for adjustment of weight less than 10 mg.
8. When weighing is completed, arrest the beam and record the weight.
9. Clean any accidental spillages and close the balance case.

Care and maintenance :

1. Balance should be placed on a firm base, free from mechanical vibrations.
2. Balance room must be separate in order to protect from fumes and balance should be located in a draught free position away from direct sun light.
3. When not in use, balance beam should be raised in order to protect the knife edges.
4. Doors of the balance must be kept closed whenever possible.
5. Pillar should be arranged vertically by adjusting the levelling screws and observing the plumb line.
6. Pans should be maintained clean and dry.
7. To release the balance, beam should be lowered gently.
8. Objects / substances to be weighed must attain the temperature of the balance before weighing. This will prevent the air currents to be produced inside the balance, thus preventing the weighing errors by the air currents.
9. Chemicals which can injure the pans should not be directly kept on the pans. Weighing bottles or watch glasses or weighing funnels should be used for the

purpose. Liquids, volatile solids and hygroscopic solids should be weighed in stoppered weighing bottles.

10. Objects or substances to be weighed must be kept on the left pan and weights on the right pan.
11. Weights should not be touched by hand. Forceps must be used for the purpose.
12. Beam should be arrested while changing or when not in use.
13. Doors should be closed while observing the movements of the pointer on the ivory scale.
14. Balance should not be over loaded above specifications.
15. After weighing is completed, spillings on the pan or floor of the balance must be removed. Pans should be cleaned at regular intervals with a camel hair brush to remove the dust being collected.
16. A beginner should seek the help from a skilled operator.

Application : It is used for measurement of mass in quantitative analyses. .

Two knife single pan balance

Two knife single pan balance was introduced by E. Mettler in 1946. Important developments culminating in the development of two knife single pan balance are

- a) A periodic balances
- b) Dial controlled weight loading
- c) Controlled release mechanism
- d) Preweighing devices

Principle : Weighing is accomplished by substitution. Weight of the object on the pan is substituted for the weights removed from the carrier.

Construction: Two knife single pan balance consists of

1. Unsymmetrical balance beam
2. One balance pan with suspension replaced by a counter poise
3. Dial operated weights suspended from a carrier
4. Optical scale

Operation :

1. Sit opposite to the centre of the balance.
2. Clean the pan with camel hair brush.
3. Carefully replace the beam and check for zero reading.
4. Place the object at room temperature on the pan and close the balance case.
5. Remove the weights from the carrier to compensate for the weight of the object.
6. Allow the beam to take up resting position and read the weight of the object from optical scale.

Care and maintenance :

1. Balance should be kept on a firm base, free from mechanical vibrations.
2. Balance room must be separate.
3. Case must be closed, when not in use.
4. Objects to be weighed must attain the temperature of balance before weighing.
5. Chemicals which can injure the pan should not be directly kept on the pan.
6. Balance should not be over loaded above specifications.
7. After weighing is completed, spillings on the pan or floor of the balance must be removed. Pans should be cleaned at regular intervals with a camel hair brush to remove the dust, being collected.
8. A beginner should seek the help from a skilled operator.

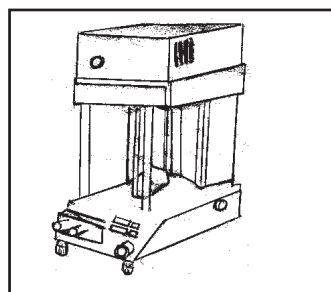
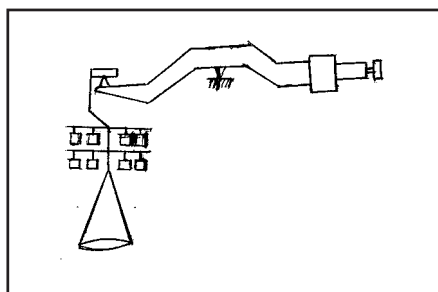

Application and Use : It is used in accurate weighing for quantitative determinations.

Electronic balance

Electronic balance is modification of two knife single pan balance. In this type of balance, optical readout system is replaced by electrically operated measuring system.

Principle : 1. Weighing is accomplished by substitution principle.

2. Fractional part of the weight is determined with the aid of electrical sensor. Electrical sensor responds to the deflection of the beam and modulates amplifier. As the result, produced current in the compensation system current gives rise to a magnetic field. It maintains the beam in equilibrium. Magnitude of the current necessary to produce requisite magnetic field is proportional to the weight being determined.

Construction : Unsymmetrical balance beam

2. One balance pan
3. Dial operated weights with a carrier
4. Electrical sensor to determine fractional weight
5. Digital display to give the weight of the object / substance
6. Print out unit to give the weight in printed form

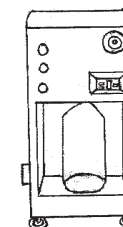

Application and Use : It is used for accurate weighing in quantitative determinations.

Top loading balance:

Top loading balance can measure masses upto 1 kg. rapidly with accuracy of 0.1g. Models to weigh upto 5kg. masses with accuracy of 0.1g., upto 200 g. with accuracy of 0.01 g. or 0.001 g. are also available.

In this model, for weighing upto 1 kg., weights moving in steps of 100 g. are controlled by a knob at the side of the balance. Weight selected appears on optical read out panel. Remaining weights (Tens, units, tenths of gram) appear on same read out panel. They are obtained from magnified image of graticule attached to balance.

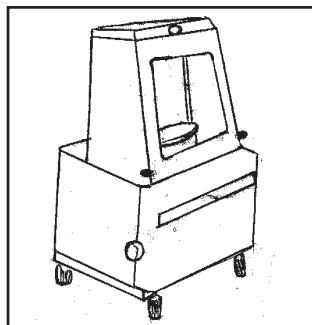

Balances of this type contain special knife suspension system. Speed of weighing is achieved by magnetic damping device. It reduces oscillations of beam. A taring device is useful to weigh out given quantity of material.

Torsion suspension balances:

In this model beam is replaced by two comparatively slender, parallel beams.

There are no knife edges. Beam need not have to be arrested. Speed of weighing is thus enhanced.

Torsion Balances :

In this type, a fine wire is stretched taut. Horizontal beam is attached to its mid point. If weight is placed at one end of the beam, wire is twisted. With the help of a graduated dial, attached to one end of the wire, it can be rotated manually until the beam is returned to horizontal position. Dial can be calibrated against known weights so as to read the weight directly.

Electro balance :

Electro magnetic force is used to counter act deflection of balance beam which is caused by adding a weight to one side. A wire coil is attached at right angles to the fulcrum of the beam. Coil is mounted between the poles of a permanent magnet. If a current is passed through coil, resulting electromagnetic interaction applies a torque to the beam. Current is adjusted by means of a potentiometer until the beam is restored to zero position. Sensitivity of 0.1 to 0.02 micrograms can be achieved.

III) **Evaporation :** Evaporation is the process of conversion of liquid into vapour at temperatures below boiling points. This technique can be used for purification of substances. Substance to be purified can be dissolved in a suitable

solvent. Solvent on evaporation removes sum of the impurities. Evaporation is allowed to take place by taking the solution in porcelain crucible. Solvent on evaporation leaves purified substance in the crucible. This process can be used for obtaining purest substance in volumetric analysis. It can also be used for preparation procedures. This can also be useful for recrystallisation.

IV) Distillation :

Distillation is the process where in liquid is boiled and its vapours are condensed to collect the liquid. By this process liquid is cleared off from the impurities soluble in the liquid.

Distillation is used in labs for preparation of distilled water. It can be done in a lab using any of the following methods.

- 1) Glass assembling
- 2) All glass distillation apparatus
- 3) Stainless steel distillation apparatus

Process of distillation consists of

- 1) Boiling the liquid
- 2) Condensing the vapours
- 3) Collecting the distillate

Distillate is the liquid formed by condensation of vapours of the boiled liquid.

Simplest process of distillation is using glass assembling. It consists of assembling round bottom flask, bent glass tube, condenser and receptacle. In this process, liquid is taken in round bottom flask. It is boiled with the help of Bunsen burner. Liquid on boiling forms vapours. These vapours pass into condenser. These vapours condense in the condenser due to continuous cooling provided by continuous circulation of water. Continuous circulation of water is provided by inlet and outlet attached to the condenser. Vapours condensed in condenser are collected into the receptacle. It is called as distillate.

V) Refluxing : During some chemical reactions, a volatile solvent may have to be subjected to boiling continuously for some hours. In such instances volatile solvent gets evaporated. It is necessary in such instances to recover the solvent being evaporated again into the reaction vessel. This can be done by taking the reactive substances in the reacting vessel, arranging the condenser at the neck of

the vessel (round bottom flask), providing constant circulation through the inlet and outlet of the condenser and heating the liquid by means of Bunsen burner. © Constant water supply provides constant cooling to continue condensation for recovery of solvent being evaporated.

VI) *Drying different salts and desiccation:* In quantitative determinations, accuracy of results is dependent on the purity of the reagents. In some cases, anhydrous salts are used as standards. When product of guaranteed quality is not available, salt has to be dried at recommended temperature. Drying is carried in hot air oven. It is again cooled to room temperature. During this period, there is a chance of salt becoming hydrous again by taking moisture from surrounding atmosphere. This can be prevented by cooling the dried salt in a crucible in a desiccator.

Ex: 1) Potassium hydrogen phthalate used for standardisation of sodium hydroxide is dried at 120°C for 2 hours. It is allowed to cool in desiccator.

Ex: 2) A.R. quality anhydrous sodium carbonate is 99.9% pure. It contains little quantity of moisture. It is used in standardisation of hydrochloric acid solution. Before use salt should be heated at 260-270°C for half an hour. Then it should be allowed to cool in a desiccator and then it should be used in volumetric analysis.

SUMMARY

Centrifugation, filtration, weighing, evaporation, distillation, refluxing, drying and desiccation of salts are some of the lab operations, a lab technician has to be well-versed with. Centrifugation requires centrifuges. Filtration is simply done using funnel and filter paper. Weighing is accomplished using different types of balances. Evaporation helps in purification. Distillation is useful for preparation of distilled water and purification. It requires distillation apparatus. Refluxing reduces loss of volatile solvent and it requires round bottom flask and condenser. Drying is done in a hot air oven and desiccation requires desiccator.

Essay Questions

1. What are different types of centrifuges? Write about electrical centrifuge in detail.
2. Write about high speed centrifuge, ultra centrifuge and refrigerated centrifuge.
3. Mention different types of balances. Write about simple balance in detail.
4. Write principle, construction, operation, care and maintenance of Two Knife Single Pan balance.

5. Explain a) Filtration using funnel b) Evaporation
6. Write about a) Distillation b) Refluxing

Short Answer Questions

1. Give the principle of centrifuge.
2. Mention different types of centrifuges.
3. What are the applications of centrifuges in a medical laboratory?
4. Mention the types of balances on the basis of accuracy in weighing.
5. Give the principle of simple balance.
6. Write the principle of two knife single pan balance.
7. What is the principle of electronic balance?
8. Explain the terms a) Slurry b) Filtrate
9. Define a) Evaporation b) Distillation
10. What is refluxing?
11. Write the purpose of drying salts and desiccation.
12. Mention the types of distillation apparatus used in lab.

6. WATER, CHEMICALS AND RELATED SUBSTANCES

WATER :

Formula : H₂O

Molecular weight : 18.02

Water is the most important constituent of all forms of life. It constitutes 70-90% of living forms. It is bland liquid. It is present in salts as water of hydration or as adsorbed superficially. Water is highly reactive. Structure of water is H-O-H. It has higher melting point, boiling point, heat of vapourisation, heat of fusion and surface tension. H-O-H bond angle in water is 104.5°. Water molecule is formed by overlap of 1s orbitals of hydrogen atoms with two sp³ orbitals of oxygen. Water molecules are bonded together by hydrogen bonds.

Ionisation of water : Water dissociates into hydrogenium ion (H⁺) and hydroxide (OH⁻) ion.

Ionic product of water : Dissociation of water is an equilibrium process.

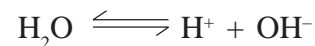

Equilibrium Constant :

$$(\text{K}_{\text{eq}}) = \frac{[\text{H}^+][\text{OH}^-]}{[\text{H}_2\text{O}]}$$

Solvent property : Water is a better solvent than many other liquids. Many salts and ionic compounds dissolve readily in water.

Purified water : Water for laboratory use is purified water. Purified water for laboratory use is prepared by any of the following process.

1) Distillation 2) Ion-exchange 3) Reverse Osmosis.

Water purified by distillation is called distilled water. Water obtained by percolation through Ion-exchange resins is called De-ionized water. Distilled water is usually prepared employing electrically heated glass distillation assembling or stainless steel distillation still. De-ionized water is obtained by percolating tap water through ion-exchange resins. Strong acid resins will remove anions

from water. Commercially available units are permutit, Elgastat etc. In reverse osmosis, an aqueous solution is separated from pure water by semi-permeable membrane and sufficient pressure is applied to solution. This causes water to flow from aqueous solution into pure water instead of from pure water into aqueous solution as happens in osmosis. This principle of reverse osmosis is adopted in Milli-Q3 system of Millipore corporation.

Standards laid down for purified water : Indian Pharmacopoeia prescribes limits for albuminoid ammonia, ammonia, oxidisable matter, non-volatile matter, copper, iron and lead, chloride and sulphate. pH of water is 4.5 to 7.0. British pharmacopoeia prescribes limits for non volatile residue as 0.005% W/V, residue after ignition as 0.002% W/V, 5 to 7.5 for pH, 10 meq ohm⁻¹ per cm. for conductivity.

PURITY OF CHEMICALS :

Substances used in the analysis for diagnosis must be pure so as to get results with accuracy and precision. It is quite difficult to get an almost pure substance. We get chemicals of varying degrees of purities. For example: Glucose, Sodium Chloride and many salts are available with over 99% of purity while many others contain traces of impurities.

Purity : Purity means state of not containing any impurities.

Impurities : Impurities are foreign substances present along with the chemical, which may affect the result of analysis.

Accuracy : Accuracy is defined as nearness of the measured values of a physical quantity to its true value.

Precision : Precision can be defined as nearness among the measured values of a quantity.

Analysis : Resolution of a chemical compound / specimen into its proximate or ultimate parts and determination of its elements or of the foreign substances (impurities) it may contain.

Qualitative analysis : Qualitative analysis is ascertaining the nature of the substances or impurities present in a specimen or chemical substances.

Quantitative analysis : Quantitative analysis is determination of how much of each component or components is present in the chemical compound or specimen.

Partial analysis : Partial analysis is determination of selected constituents in the sample.

Trace constituent analysis : Trace constituent analysis is determination of specified compounds present in a compound in minute quantities.

Complete analysis : Complete analysis is determination of each component of the sample.

Trace constituent : Trace constituent is one, present to an extent of less than 0.01 per cent of the sample.

Minor constituent : Minor constituent is one which is present in quantities from 0.01 to 1% of the sample.

Major constituent : Major constituent is one which is present in above 1% of the sample.

Grading of Reagents :

The purest available reagents should be employed in analysis to get results with accuracy and precision. Reagents supplied by the manufacturers are graded as per purity into -

1. Analytical reagent quality (AR) or Anala "R"
2. Guaranteed reagent quality (GR)

Anala "R" and GR chemicals are highly pure qualities and are mainly used for the preparation of quantitative reagents.

3. General purpose reagent quality (GPR) :

Where AR & GR quality is not needed and when purity within certain limits is required, GPR quality is used.

4. Laboratory reagent quality (LR) :

This quality is used for preparation of qualitative reagents such as Fehling's

solution, Selvinoff's reagent, Benedict's reagent, Fouchet's reagent etc.

Sources of Impurities :

Type and amount of impurities present in the chemicals depends upon several factors.

Some of them are

1. Raw materials employed in the manufacture
2. Method or process used in the manufacture
3. Chemical processes employed in the processes.
4. Plant materials employed in the process
5. Container materials used for storage of final products
6. Decomposition during keeping
7. Adulteration

1. Raw materials employed in the manufacture:

If the Raw materials employed in the manufacture of chemicals contain impurities, they get incorporated into the final product. Impurities like arsenic, lead, heavy metals etc. will be present in raw materials and hence found in the final product.

2. Method or process used in the manufacture :

For certain chemicals, a multi step synthesis procedure is involved during which, intermediate compounds are produced. If these intermediates are not purified, they will enter into the final product. Impurities in such cases depend on the method followed.

3. Chemical processes employed :

In the synthesis of chemicals, many chemical reactions like oxidation, reduction, hydrolysis, nitration and halogenation etc. are involved. In these processes, several solvents and chemicals related to these processes are employed. They may be incorporated into the final product. Ex: Chlorides may be incorporated if HCl is used. Sulphates may be incorporated if H_2SO_4 is used.

4. Plant materials employed in the process :

Chemical reactions are conducted in reaction vessels or containers to manufacture the chemicals needed for use in the diagnosis. Materials of construction of these vessels like Iron, Copper, Tin, Aluminium etc. or the products of their reaction with raw materials or intermediates may be incorporated into the final product. Thus, presence of impurities such as Iron, Copper, heavy metals is due to above mentioned reason.

5. Container materials used for storage of final products :

Final products are stored in different containers made of different types of materials such as Plastic, Polyethylene, Iron, Stainless steel, Aluminium, Copper, Glass etc. Due to reaction between the contents and the containers, those reaction products may be coming as impurities.

Ex: Alkalies stored in glass containers extract lead from it.

Strong chemicals stored in Iron containers extract Iron.

6. Decomposition during keeping :

Some substances decompose on keeping and the decomposition is greater in the presence of light, air or oxygen. A number of organic substances get spoiled because of decomposition on exposure to atmosphere. Ex: Amines, Phenols etc. Decomposition products thus appear as impurities in the substances.

7. Adulteration :

Deliberate adulteration using similar materials also accounts for the presence of impurities in the substances.

Ex: Adulteration of sodium salt with potassium salt, calcium salts with magnesium salts etc.

Effects of Impurities :

1. Impurities may bring about changes in physical properties of the substances like colour, odour, taste etc.
2. Impurities may bring about chemical changes rendering the chemical reagent useless.

3. Impurities may act as interfering substances, thus affecting the accuracy of the result adversely.

4. Impurities may affect active strength of the substance influencing the result accordingly.

5. Impurities may lower the shelf life of the substance.

Tests for Purity :

Tests for purity are tests for detecting impurities in the substances. Governing factor for these tests is to determine how much impurity is likely to bring about technical and other difficulties, when the substance is used in analysis. Certain tests which are carried out on the substances are 1. Colour and Odour 2. Physico chemical constants 3. Reaction and pH. 4. Semi micro analysis 5. Insoluble residue 6. Ash, water insoluble ash.

1. Colour, Odour etc. :

When other tests for purity are not available, tests of colour, odour may be employed. Though they have limited value, they are useful in determining whether the substance is reasonably pure.

2. Physico Chemical Constants :

Solubility in various solvents, determination of melting and boiling points for organic substances, optical rotation for optically active substances and refractive index for liquids are some tests of purity. Determination of acid value, saponification value, iodine value, acetyl value etc are for oil. However, low concentrations of impurities may not alter these constants and thus remain undetected unless tested specifically.

3. Reaction and pH :

Solutions of certain substances have a definite pH at a given concentration. Presence of impurities will change the pH. In this way, tests for reaction and determination of pH are of great value in estimating the extent of impurities if they can affect reaction.

4. Semi micro analysis :

Organic and inorganic substances prepared by using strong acids like HCl

and H_2SO_4 contain impurities as chloride and sulphate ions (anions). Tests for cations like sodium, ammonium are often carried out. Tests for heavy metals like Lead, Iron, Copper and Mercury are also carried out as these are the very common impurities in the substances.

5) Insoluble residue :

Pure substances give a clear solution in a given solvent. When insoluble impurities are present in the substances, solution appears cloudy or opalescent. Measurement of opalescence or turbidity helps in determination of impurities. If the insoluble residue is high, it can be filtered, dried and weighed.

6. Ash, water insoluble ash :

Determination of ash in crude vegetable drugs, organic compounds and some inorganic compounds gives a good indication about the extent of impurities of heavy metals or minerals. In certain cases, water insoluble ash is also determined to find out water insoluble heavy metals & mineral type of impurities.

CORROSIVES

Corrosive chemicals are those substances which can cause destruction of living tissues.

Different chemicals of corrosive nature have to be handled by a technician in a laboratory. Acids and alkalies have to be used for acidimetry and alkalimetry. They also find application for providing acidic medium and alkaline medium for facilitating qualitative and quantitative determinations.

While handling these substances, they can cause corrosion, if they fall on any part of the body. A technician should be well-versed with the measures of preventing accidental happenings, first aid measures on such happenings, precautions to be followed during dilution of concentrated acids and alkalies and their storage aspects.

Accidental happenings by corrosives may be due to

1. Spilling of splashes on the skin during handling
2. Spilling of splashes into the eye
3. Swallowing in to the mouth during pipetting

Classification of corrosive substances: Corrosive substances can be classified into categories on the basis of degree of corrosiveness, they can cause.

1) Substances with high degree of corrosiveness

- a) Strong acids
- b) Strong alkalies

2) Substances with lesser degree of corrosiveness

- a) Weak acids
- b) Weak alkalies
- c) Phenols and cresols having weakly acidic nature

Strong acids :

Strong acids are the substances which are ionised to the extent of 100%. Examples are Hydrofluoric acid, Hydrochloric acid, Sulphuric acid, Nitric acid etc.

Strong alkalies :

Strong alkalies are those, which are ionised to the extent of 100%. Examples are NaOH, KOH and $\text{Ba}(\text{OH})_2$.

Weak acids:

Weak acids are those, which are ionised to the extent of less than 100%. Ex. Glacial acetic acid, Phosphoric acid, Nitrous acid etc.

Weak alkalies:

Weak alkalies are those, which are ionised to the extent of less than 100%.

Phenols and Cresols :

Phenols are aromatic hydroxy compounds in which OH group is directly attached to the Benzene ring.

Ex: Phenol, Nitrophenol, Picric acid.

Cresols are the next homologues of phenol. They have resemblances with phenols in most of their characteristics.

Hydrochloric acid:

Formula : HCl , Molecular weight: 36.5 .Concentrated hydrochloric acid is a preparation of hydrogen chloride in water. It contains not less than 35.0% w/w and not more than 38% w/w of HCl. It is available commercially in the concentration of 10.5 - 12 M (10.5-12N).

Properties : It occurs as a colourless fuming liquid with pungent odour. It is miscible with water and alcohol. Its specific gravity is 1.18. It is a strong acid and attacks metals.

Dilution of the concentrated acid : While diluting the concentrated HCl acid, it is gradually added to water, mixed and cooled.

Safe handle the acid to avoid corrosion to the body parts -skin, eyes,mouth,tongue and lip.

Storage : Store in well closed containers. Store at low levels.

Sulphuric acid :

Formula : H_2SO_4 , Mol weight: 98,

It contains not less than 95.0% w/w of H_2SO_4 . It is available commercially in strength of 18 M (36N).

Properties : It is a colourless fuming acid. It has oily consistency. It is miscible with water. Specific gravity is 1.84.

Dilution of the concentrated acid : While diluting, add acid gradually to water, mix and cool.

Safe handle to avoid corrosion to the body parts like skin,eyes,mouth,tongue and lips.

Storage : Store in well closed containers. Store at low levels.

Phosphoric acid: It is also called as orthophosphoric acid. Molecular weight is 98. Formula is H_3PO_4 . It contains 88% to 90% w/w of H_3PO_4 . It is commercially available in strength of 17N.

Properties : It is a colourless syrupy liquid. It is miscible with water and alcohol. It loses water on heating and finally converted to meta phosphoric acid, which forms a transparent mass on cooling.

Storage : Store in well closed containers. Store at low levels.

Sodium Hydroxide :

Formula : NaOH Molecular weight : 40

It is also called as caustic soda. It contains not less than 95% of total alkali calculated as NaOH and not more than 2.5% of Na_2CO_3 .

Properties : It is available as pellets, flakes or sticks. It is extremely hygroscopic. It absorbs atmospheric CO_2 and partially converted to Na_2CO_3 . It is freely soluble in water, alcohol and glycerine. Heat of solution is produced during dissolution.

Safe Handling : 1. Handle carefully 2. Handle the concentrated solutions to avoid spilling on to skin, into eye and swallowing into mouth.

Storage : It must be stored in air tight containers. Its concentrated solutions must also be stored in air tight containers. Exposure to atmosphere causes absorption of atmospheric CO_2 partially converting to Na_2CO_3 .

Potassium hydroxide :

Formula : KOH Molecular weight : 56.1

It contains not less than 85% of KOH and not more than 4% of K_2CO_3 .

Properties : It is available as dry hard, brittle, white flakes, sticks or fused masses. It is highly hygroscopic.

Handling : 1. Handle carefully

2. Handle the concentrated solutions to avoid spilling on to skin, into eye and swallowing into mouth.

Storage : It must be stored in air tight containers. Its concentrated solutions also must be stored in air tight containers. If they are exposed to atmosphere, partially it will be converted into K_2CO_3 by absorbing atmospheric CO_2 .

Acetic acid :

Formula CH_3COOH Molecular weight : 60

It is also called as glacial acetic acid. It is commercially available in strength of 45N.

Properties : It is a colourless liquid, It is soluble in water. It has a specific gravity of 1.71. It has oily consistency.

Dilution : Add gradually to water, mix and cool.

Handling : Handle carefully.

Storage : Store in well closed container.

Ammonium hydroxide :

Formula : NH_4OH Molecular weight :35

It contains not less than 27% and not more than 30% w/w of NH_3 .

Properties : It is a clear colourless liquid having a strong pungent odour and a characteristic taste. It is miscible with water.

aqueous solution is strongly alkaline.

Handling : Handle carefully.

Storage : It is stored in a well closed container in a cool place. It is stored in amber coloured bottles with a rubber stopper.

Phenols and Cresols :

Phenols are colourless crystalline solids or liquids with characteristic odour. They darken in air due to oxidation. Phenols and cresols are sparingly soluble in water. Di and trihydric phenols are fairly soluble. They dissolve readily in alcohol and ether. Phenols are weakly acidic.

Phenol :

Hydroxy Benzene, $\text{C}_6\text{H}_5\text{OH}$

It is also called as carbolic acid

It produces painful blisters on the skin.

Properties : 1. Phenol is available as colourless needle like crystals.

2. It is extremely hygroscopic.

3. It turns to pink when exposed to air and light.

4. It has a strong carbolic odour and burning taste.

5. It is sparingly soluble in water but dissolves readily in alcohol, ether and benzene.

6. It is weakly acidic.

Cresol :

$\text{CH}_3\text{C}_6\text{H}_4\text{OH}$

There are three forms " o ", " m ", and " p " cresols. They are prepared from coaltar.

Properties : 1. They have most of the properties similar to phenol.

2. They are less toxic than phenol.

Solids and Hygroscopic substances :

Solids : Various solid chemicals are used in biochemical analysis. They are used as solutions or added during a chemical reaction. As solutins, they are either used in quantitative determinations or qualitative identification.

States of matter :

There are three states of matter. They are 1. Solids 2. Liquids 3. Gases

Solids are characterized by a definite shape, incompressibility, rigidity and mechanical strength. Constituent particles of solids are closely packed, held together by strong cohesive forces and cannot move at random.

Characteristics of Solids :

1. Solids have definite shape and size.
2. Solids are rigid and incompressible.
3. Most important property of solid is regularity of form.
4. They have high density.
5. Solids convert to liquid state at melting point.
6. Molecular motion in solids is vibratory motion.

Classification of solids :

Solids are classified into two categories based on the regular or irregular distribution of building particles. They are 1. Crystalline solids 2. Amorphous solids.

Crystalline Solids : Crystalline solid is a solid substance whose constituents are arranged in an orderly manner to give a definite geometrical form.

Ex: Sodium chloride, sugar, diamond, potassium chloride etc.

Amorphous solids : Amorphous solid is a substance whose constituent particles are not arranged in an orderly manner. Amorphous solids do not have definite geometrical form. They are also incompressible and rigid to a certain extent.

Ex: Glass, rubber and plastics.

Characteristics of Crystalline Solids and Amorphous Solids :

1. **Characteristic Geometry** : Crystalline Solids have definite and regular geometric shape. Amorphous solids have no definite geometrical shape.
2. **Melting Points** : A crystalline substance has a sharp melting point, where as amorphous solids do not have sharp melting point. This is due to variation in atomic distances between different atoms and hence different bond strengths. When such solids are heated, all the bonds do not break at a single temperature and hence there is no sharp melting point.
3. **Isotropy and anisotropy** : Amorphous solids are isotropic all the properties like refractive index, electrical conductivity, thermal conductivity and mechanical strength are same in all directions. Crystalline solids are anisotropic. Properties like refractive index, electrical conductivity etc. depend on the direction along which they are measured.
4. **Cleavage planes of crystalline solids** are well defined where as amorphous solids do not have well defined cleavage planes.
5. **Crystal Symmetry** : Amorphous solids do not have crystal symmetry.

Hygroscopic Substances : Hygroscopic substances are those which absorb moisture from atmosphere.

Ex: Aluminium Chloride (AlCl_3), Concentrated H_2SO_4 , Calcium Oxide (CaO), Magnesium trisilicate, Ethanol, Sodium Bromide (NaBr) etc.

Deliquescent substances : Deliquescent substances are those which absorb moisture from atmosphere and become aqueous solutions. Ex: Sodium hydroxide (NaOH), Potassium Hydroxide (KOH), Magnesium Chloride ($\text{MgCl}_2 \cdot 6\text{H}_2\text{O}$), Calcium Chloride ($\text{CaCl}_2 \cdot 6\text{H}_2\text{O}$), Zinc Chloride ($\text{ZnCl}_2 \cdot 6\text{H}_2\text{O}$), Sodium Nitrate (NaNO_3).

Both hygroscopic and deliquescent substances possess one property in common - Absorption of water from atmosphere on exposure to air.

Efflorescent substances: Efflorescent substances are those which lose water on exposure to air.

Ex: Sodium citrate, Epsom salt ($\text{MgSO}_4 \cdot 7\text{H}_2\text{O}$), Sodium carbonate ($\text{Na}_2\text{CO}_3 \cdot 10\text{H}_2\text{O}$), Sodium thiosulphate ($\text{Na}_2\text{S}_2\text{O}_3 \cdot 5\text{H}_2\text{O}$), Copper sulphate ($\text{CuSO}_4 \cdot 5\text{H}_2\text{O}$), Glauber's sulphate ($\text{Na}_2\text{SO}_4 \cdot 10\text{H}_2\text{O}$), Ferrous Sulphate ($\text{FeSO}_4 \cdot 7\text{H}_2\text{O}$).

Hydrous Salts : Salts which usually exist as hydrates i.e., containing water molecules in their structure are called as hydrous salts or hydrates.

Ex: Copper Sulphate ($\text{CuSO}_4 \cdot 5\text{H}_2\text{O}$), Epsom Salt ($\text{MgSO}_4 \cdot 7\text{H}_2\text{O}$).

Anhydrous salts:

Salts which usually exist as non-hydrates i.e., not containing water molecules in their structure or whose water molecules are removed by heating are called as Anhydrous salts.

Ex: Anhydrous Aluminium Chloride.

Aluminium Chloride :

Formula : AlCl_3 Molecular weight 133.48

It is a hygroscopic salt. On exposure to air, it absorbs moisture. It is prepared from Alumina. Alumina, when mixed with charcoal and heated in atmosphere of dry chlorine gas yields anhydrous aluminium chloride. It exists as dimers (Al_2Cl_6). It becomes monomeric (AlCl_3) only at 400°C . It is soluble in organic solvents like alcohol, ether, nitro benzene, etc. It has ready volatility and hydrolysis due to which it fumes in warm air liberating hydrogen chloride.

Concentrated H_2SO_4 : See corrosives

Magnesium tri silicate :

Formula : $2\text{MgO} \cdot 3\text{SiO}_2 \cdot 3\text{H}_2\text{O}$ (or $4\text{H}_2\text{O}$)

It is slightly hygroscopic substance. It is prepared by running a solution of sodium silicate into equimolar solution of magnesium sulphate or magnesium chloride. It is a white or nearly white fine powder. It is odourless, tasteless. It is insoluble in water and alcohol. It can be readily decomposed by mineral acids.

SUMMARY

Water is the most important constituent of all forms of life. It is highly reactive. It ionises as hydronium ions and hydroxyl ions. Water is a good solvent. Presence of water also has effect on chemical and microbial stability of many substances. Purified water is water for laboratory use. It is prepared by distillation, ion exchange, reverse osmosis etc. Indian Pharmacopoeia and British Pharmacopoeia prescribe standards for purified water.

Chemical substances used in diagnostics should be pure to get results with accuracy. Reagents are graded into Anala "R" quality, guaranteed reagent quality, general purpose reagent quality and laboratory reagent quality according to purity. Quantitative work requires the purest possible reagents i.e. AR. For qualitative work, laboratory reagent quality is enough.

Purity means freedom from impurities. Sources of impurities are raw materials employed in the manufacture of reagents, method or process used in manufacture, chemical processes employed, plant materials employed, container materials used for storage, decomposition, adulteration etc.

Tests for purity of chemical reagents are colour, odour, physico chemical constants, reaction and pH, semimicro analysis, insoluble residue, ash, water insoluble ash etc. Limit tests are conducted to know if impurities are present in limits. Limit tests are conducted for chlorides, sulphates, iron, heavy metals, lead, arsenic etc. Impurities can be removed by some processes as recrystallisation from a solvent, sublimation, zone retining etc.

Corrosives are the substances which can cause destruction of living tissues. Strong acids, strong alkalies, weak acids, weak alkalies, phenols and cresols can cause corrosion in varying degrees.

Solids are characterised by definite shape, incompressibility, rigidity and mechanical strength. Solids are classified into crystalline solids and amorphous solids. Hygroscopic substances are those which absorb moisture from atmosphere. Examples are Sodium hydroxide, Potassium hydroxide etc.

Essay Questions:

1. Write about water for laboratory use.

2. What are the sources of impurities? Discuss.
3. Give the effects of impurities and write about tests for purity.
4. How are impurities removed? Give some procedures.
5. Classify corrosives.
6. Write about strong acids and strong alkalies.
7. Write characteristics and classification of solids.
8. What are the characteristics of crystalline and amorphous solids?
9. Write about hygroscopic substances.

Short Answer Questions

1. Write a) structure of water b) H–O–H bond angle
2. Mention ions of dissociation of water.
3. Write the formula of equilibrium constant of dissociation of water.
4. Write about solvent property of water.
5. What is water for laboratory use?
6. How is purified water prepared?
7. What is ion exchange?
8. Define reverse osmosis.
9. What are the limits prescribed for purified water?
10. Define a) Strong acids b) Weak acids
11. Define a) Strong alkalies b) Weak alkalies
12. Write the properties of HCl.
13. Write the properties of NaOH.
14. Mention states of matter.
15. Exemplify crystalline solids.
16. Give examples of Amorphous solids.
17. What is hygroscopic substance?

7. PREVENTION, SAFETY AND FIRST-AID **IN LAB ACCIDENTS**

A lab worker should be well-versed in laboratory safety procedures. Alertness and cautiousness are the things of requisition for any one concerned with laboratory. One is surrounded by many dangers from corrosive substances, poisonous chemicals, explosive chemicals, inflammable chemicals etc. Almost all the chemicals except a few used in a clinical laboratory are lethal poisons. Appropriate methods of safe handling, handling the situations, rendering the first aid in case of accidental happenings are to be well known to technicians working in different areas of diagnostics such as Biochemistry, Micro Biology, Serology, Clinical pathology, Haematology, Blood banking and Histopathology.

One must be familiar with safety procedures for personal safety as well as fellow technicians. Safety procedures are also required for workers in chemical laboratory, Biochemical and Microbiological laboratories not related with diagnostics also.

Accidental happenings in a laboratory can be caused by

- | | |
|---------------------------------------|--|
| 1) Acids and alkalis. | 2) Toxic, harmful and irritating chemicals |
| 3) Oxidising chemicals | 4) Carcinogenic chemicals |
| 5) Infectious specimens and materials | 6) Glass ware |
| 7) Heat | 8) Fire |
| 9) Explosion | 10) Electrical shock. |

1) Acids and Alkalies :

Acids, Alkalies and phenols which are corrosive in nature are used in a laboratory. Corrosives cause damage to the living tissues with which they come into contact. They can cause bodily damage due to a) Spilling of their splashes on skin b) Spilling of splashes into eye. c) Swallowing during mouth pipetting d) Contact with lip and tongue.

Acids : Acids are capable of causing corrosion when they come into contact with body parts. Different Acids used in a laboratory are, Hydrochloric acid, Sulphuric acid, Nitric acid, Acetic acid, Trichloro acetic acid etc.

Precautions for preventing spilling on the skin :

- 1) Wear cotton apron while handling. Cotton is the fabric of choice for apron. Cotton has great absorptive capacity.
- 2) Wear rubber gloves.
- 3) Direct the mouth of the vessel away from you and your fellow technicians while heating.
- 4) Do not lean over the vessel.

First aid in case of spilling of Acid splashes on the skin :

- 1) Wash the affected part with plenty of water.
- 2) Apply cotton wool soaked in 5% sodium carbonate solution over the affected part.
- 3) Consult a physician.

Precautions for preventing spilling of acid splashes in to the eye :

- 1) Handle well below the eye level.
- 2) Wear protective eye glasses or shields while opening the container.
- 3) Do not look into the container through the mouth while heating.

First aid in case of Spilling of Acid splashes into the eye :

- 1) Wash the eyes immediately with plenty of tap water. Water can also be sprayed from a wash bottle or rubber bulb. Squirt water into the corner of the eye near the nose.
- 2) Instill four drops of 2% sodium bicarbonate.
- 3) Consult ophthalmologist immediately.

Precautions to be taken to prevent swallowing :

Avoid mouth pipetting or use rubber or plastic tubing for safe mouth pipetting.

First aid in case of Swallowing :

- 1) Make the victim drink 5% soap solution or 8% $\text{Mg}(\text{OH})_2$ or white portion of two eggs combined with 500 ml. of water or atleast plenty of ordinary water.
- 2) Make the victim gargle with soap solution.

Precautions to be taken to prevent contact with lip and tongue :

Avoid mouth pipetting or use rubber / plastic tubing for safe mouth pipetting.

First Aid in case of contact with lip and tongue :

- 1) Immediately rinse in tap water.
- 2) Bathe the affected area with 2% aqueous solution of sodium bicarbonate.

Precautions to be taken during dilution of concentrated acids :

Dilute by adding acid to water gradually and stirring constantly. Addition of even small quantity of water to concentrated acid will produce large quantity of heat and vessel will break.

Akalies : Alkalies are more corrosive than or as corrosive as acids. Sodium hydroxide, Potassium hydroxide, Ammonium hydroxide etc. are the alkalies used in a laboratory.

Prevention of spilling of Alkali splashes on the skin :

- 1) Wear a cotton apron while handling.
- 2) Wear rubber gloves.
- 3) Direct the mouth of the vessel containing alkali away from your self and fellow technicians.
- 4) Do not lean over the vessel while reaction is going on.

First aid in case of spilling of Alkali splashes on the skin :

- 1) Wash the affected skin with plenty of tap water.
- 2) Bathe the affected area with cotton wool soaked in 5% acetic acid.
- 3) Consult a physician

Prevention of spilling of Alkali splashes into eye :

- 1) Handle below the eye level.
- 2) Wear Protective eye shields
- 3) Do not look in to the container while heating.

First aid in case of spilling of Alkali splashes into eye :

- 1) Wash immediately with plenty of water holding the eye lids apart by spraying into the corner of the eye near the nose.
- 2) Rinse with saline water.
- 3) Instill the drops of saturated solution of boric acid repeatedly.
- 4) Consult an ophthalmologist immediately.

Prevention of slallowing of alkalis :

Do not attempt mouth pipetting or attempt to safe mouth pipetting with the help of rubber or plastic tube.

First aid in case of accidental swallowing :

- 1) Rinse the mouth with tap water and make the patient drink 5% acetic acid solution or lemon juice.
- 2) Make the victim drink 3-4 glasses of water.
- 3) Consult a physician.

Prevention of Contact with Lip and tongue :

Avoid mouth pipetting or attempt to safe mouth pipetting using rubber or plastic tube.

First aid in case of contact with lip and tongue :

- 1) Rinse immediately with plenty of water.
- 2) Bathe the affected part with 5% acetic acid solution.
- 3) Consult a physician.

First aid in case of contact of skin with phenol :

- 1) Wash the contacted area with large quantities of water.
- 2) Spray the aqueous solution of polyethylene glycol (PEG) over the affected area of the skin.
- 3) Consult a physician.

Storage of Corrosive chemicals :

Bottles of corrosive chemicals should be stored at lower shelves of the cup boards. Acids and alkalies should not be stored in bottles containing ground glass stoppers. Ground glass stoppers may get stuck. They should not be stocked in the laboratory in large quantities.

2. Toxic, harmful and irritating chemicals :

Toxic and harmful chemicals are those which can cause death or serious illness. Irritating chemicals are those which irritate skin, mucous membranes or respiratory tract. Potassium cyanide is well known and the most lethal poison. Xylene, Formaldehyde and Ammonia vapours are skin and mucous membrane irritants. Phenyl hydrazine, Aniline, Nitro compounds, Aromatic hydrocarbons etc are harmful to respiratory ducts, skin and whole body. Iodine, sulphamic acid, chloroform, sodium nitroprusside, mercuric nitrate, sodium azide, Barium chloride and methanol etc. also fall into the category of toxic, harmful and irritating chemicals.

Prevention of accidents with these substances :

- 1) Wear protective gloves while handling.

- 2) Wash the hands after handling.
- 3) Do not attempt to mouth pipetting.

First Aid :

- 1) If some substance falls on the hands, wash thoroughly with a brush.
- 2) When liquid bromine spills on skin or clothes or working benches, pour 20-40% Hypo solution and rinse with plenty of water. Apply vaseline to skin.
- 3) If a noxious gas like Cl_2 or Br_2 vapour is inhaled, breathe in a dilute solution of NH_3 .
- 4) A lethal poison like Potassium cyanide causes immediate death. However, when not so lethal poisons are accidentally swallowed,
a) Spit immediately b) Rinse with lot of tap water. c) Induce vomiting by drinking warm salt water.

Storage :

- 1) Store lethally toxic chemicals like potassium cyanide in locked cup board.
- 2) Stock solutions should also be kept in cup board, but not openly.

3) Oxidising chemicals :

Oxidising chemicals can produce heat on contact with other chemicals. Examples of oxidising chemicals are Potassium Dichromate, Potassium Permanganate, Potassium Iodate, Chromic acid etc.

Safe handling :

Handle with care to avoid contact with skin, eyes etc.

Storage : Keep away from flammable chemicals.

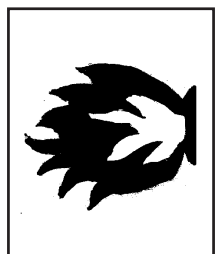

Inflammable

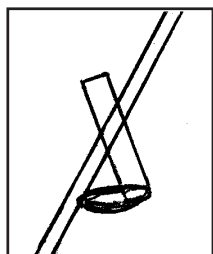

Naked Flames Prohibited

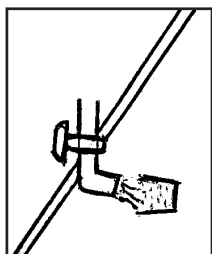

Not Drinking Water

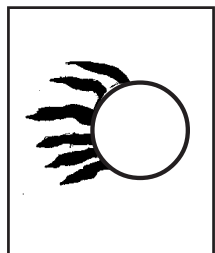

Oxidising

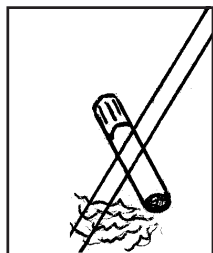

No Smoking



No Entry

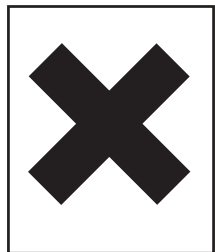

Harmful/Irritant

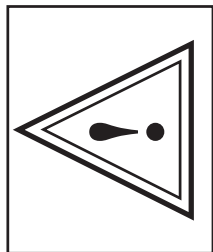

Risk of Danger

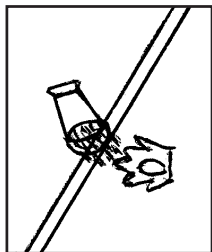

Do not extinguish with water

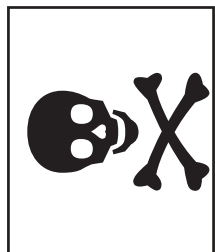

Toxic

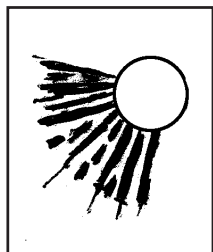

Explosive

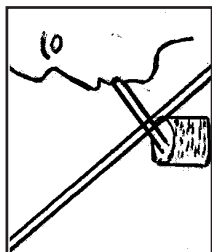

Not to be mouth Pipetted

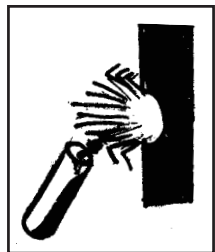

Corrosive

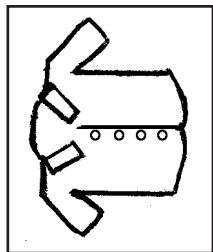

Lab Coat Mandatory

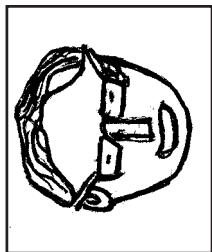

Eye Sheild Mandatory

4) Carcinogenic Chemicals :

Carcinogenic chemicals are the agents which are capable of causing cancer by ingestion, inhalation or contact with skin. Benzidine, Toluidine, 0-Dianisidine, Nitrosophenols, Alpha Naphthylamine, Beta-Naphthylamine, Selenite etc. are examples of carcinogenic chemicals.

Precautions in handling :

- 1) Wear rubber or plastic gloves.
- 2) Wear face mask.
- 3) Wear eyeshields.
- 4) Wear an apron.
- 5) Wash the apparatus, bottles, working bench and protective gloves after handling.
- 6) Change overall.
- 7) Rinse hands in cold running water.
- 8) Apply soap after rinsing hands in cold water.
- 9) Safety measure in case of contact with skin: Wash the affected part in cold running water for 10 minutes.

Storage :

- 1) Label as 'Carcinogenic'.
- 2) Give the precautions on the label for safe handling.

5) Infectious specimens and materials :

Infectious specimens are the specimens of body fluids of patients with infectious diseases like Tuberculosis, AIDS etc. Infectious materials are those, contaminated with infectious agents.

Precautions :

- 1) Wear apron.
- 2) Wear rubber or plastic gloves.
- 3) Wear face mask.
- 4) Wash the apparatus, working bench, gloves and hands after use.
- 5) Change overall.

First Aid in case of contact with skin : Touch the part with pure carbolic acid.

First Aid in case of injury by broken glass ware containing infectious specimens :

1. Wash the wound immediately.
2. Squeeze to bleed for several minutes.
3. Bathe the wounded area with antiseptic lotion.
4. Wash thoroughly with soap water.
5. Bathe second time with antiseptic lotion.
6. Consult a physician.

First Aid in case of accidental sucking into mouth or swallowing :

1. Spit it out immediately.
2. Wash the mouth with tap water.
3. Gargle the mouth with dilute antiseptic lotion.
4. Wash the mouth with large amounts of water.
5. In case of swallowing, induce vomiting with warm solution of salt.
6. Consult a physician.

6. Glassware :

Glassware can cause injury due to

- a) Breakage during handling
- b) Breakage during heating
- c) Breakage during centrifugation

If broken glassware containing infectious specimens cause injury, procedures of precautionary measures and first aid measures are as

given in the above paragraph. In case the glassware is not containing infectious specimens also, the wound should be cleaned with dilute disinfectant solution and to be covered with gauze and adhesive tape. T.T.injection can be given.

General precautions for prevention of injuries by glassware :

- 1) Do not use broken, cracked or chipped glassware.
- 2) Use pyrex glassware only for heating purposes. Do not use ordinary glassware for this purpose as they will break.
- 3) While heating a test tube, heat the middle of the test tube and not the bottom directly. Direct the mouths of the test tubes away from yourself and fellow technicians while heating.
- 4) Wipe the glass vessels before heating. Heat them gradually.
- 5) Handle small bottles and small vessels with solutions holding the entire vessel in the hand rather than the neck only. Handle the big bottles with neck in one hand and bottom supported by palm of other hand.

7. Heat : Contact with heated articles or spilling of boiling liquids or contact with heated substances can cause burns. These burns fall in to two categories.

- 1) Severe burns.
- 2) Minor burns.

Severe burns are those which affect large surface area of skin. Minor burns are those which affect a small surface area of skin. Severe burns are caused by boiling liquids. Minor burns are caused by hot glassware or bunsen flame.

Precautions :

1. Place pieces of porcelain or broken glass rod in the boiling liquids

to prevent bumping.

2. Do not heat the bottoms of test tubes. Heat in the middle portion of the solution. Direct the mouths of the vessels away from yourself and fellow technicians.
3. Remove the sterilised instruments or glassware from an oven / autoclave after lab temperature is reached. In case of drying of the glassware also, remove them from the oven after reaching of the lab temperature.
4. Use heat proof gloves fabricated from asbestos fibres in case very hot articles have to be handled.

First Aid in case of minor burns :

1. Pour cold water or ice cold water over the affected part.
2. Apply mercurchrome or acriflavine ointment to the affected part. Glycerol or cotton wool soaked in alcohol can also be used.
3. Apply a dry gauze dressing loosely.
4. Do not tear the blisters formed over burns.
5. Consult a physician.

First Aid in case of severe burns :

1. Lay the victim on the ground.
2. Do not remove clothing.
3. Cover him if the victim is cold.
4. Do not apply any treatment to the burns.
5. Inform the physician on duty.

8. Fire : Sources of fire in a laboratory are

1. Inflammable liquids
2. Gas
3. Electricity.

Inflammable liquids are those which have low flash points. Ex: Ether, Acetone, CCl₄, Alcohol, Benzene, Toluene etc. Gas supply can be source of fire accidents due to a) Leakage in the gas pipe line b) Gas cylinders left unturned off. c) Gas delivery points unturned off. Electricity is the source of fire due to short circuiting in the pipe line.

Prevention of fire accidents due to inflammable liquids :

- 1) Inflammable liquids should be stocked in the lab in small quantities.
- 2) Do not keep the bottles of inflammable liquids near the open flames, where heating procedures are conducted. Especially ether will ignite at a distance of several metres from a flame.
- 3) Heat the inflammable liquids on the baths with closed heater elements.

Prevention of fire accidents due to gas :

1. Turn off the main valves of cylinders.
2. Replace the rubber tubing once a year.
3. Turn off the gas taps each time after use.
4. Turn off the main supply points of gas to the gas pipe line in the evening hours.
5. Check for leakages in the gas supply pipelines to the lab at timely intervals.
6. Light the match stick and hold it near the flame point of the burner and then release gas.

Prevention of fire accidents due to electrical short circuiting :

Electrical wiring should be checked at timely durations.

Extinguishing of fire :

1. Water should not be used to extinguish fire caused by inflammable liquids. Sand can be used. Do not try to blow off such a fire. Use fire extinguishers in case of a big blaze.
2. If inflammable liquid in a vessel takes flame, a) Immediately disconnect supply of fuel to flame b) Make non available, the oxidant gas i.e. air to the fire in the vessel by closing with porcelain plate, metal plate, wooden plate, glass plate or towel.
3. If burning liquid spills on the floor, extinguish the fire with sand.
4. If fire happens in a laboratory, immediately turn off gas supply, electrical heaters and use fire extinguishers. If fire *has not caught organic liquids*, water can be used.
5. If fire is due to electrical short circuiting, immediately put off the main switch and use sand, carbondioxide fire extinguisher to extinguish fire. Do not use water to extinguish electrical fire.
6. Extinguish the fire on a man by means of a woolen blanket. Wrap the victim and hold for 1-2 minutes.

Fire Escape : During fire escape, one has to crawl with damp cloth covering the mouth. Covering the mouth by damp cloth filters some of the fumes and prevents inhalation of flames.

Burns caused by fire : They are two types :

- 1) *Minor burns :* Burns caused by Bunsen flame fall in to this category.
- 2) *Severe burns :* They are caused by spilling of burning ether or other inflammable organic solvent.

First Aid in case of minor and severe burns : Same as given for Heat.

9. Explosion :

Explosion causes fire and devastating damage. Explosion is caused in the laboratory by explosive chemicals and heat. Explosive chemicals are those which can explode on heating or exposure to flames or friction. Ex: Picric acid.

Storage : Picric acid should be stored under water. If it dries, it can cause explosion.

Heat produced enormously during chemical reactions can cause explosion.

Ex: Heat produced when sodium reacts with water. In such cases, continuous circulation of water should be provided to cause cooling. In a chemical laboratory, explosion occurred in 1984 due to stoppage of water supply in the middle in a similar type of reaction. Heat is also produced enormously when water is added to acid instead of acid to water during dilution of concentrated acids.

10. Electric Shock :

Electric shock is caused by faulty equipment. Particularly when they are handled by wet hands electric shock is caused. Since low-voltage alternating current (220 V) is used in a laboratory, electric shocks are rare.

Prevention :

1. Timely checking of the instruments.
2. Earthing of the instruments.
3. When electrical shock takes place, some one has to put off the main switch.

First Aid :

1. Lay the victim on the ground.
2. Give mouth to mouth respiration if necessary.
3. Send for a physician.

SUMMARY

A laboratory worker is required to be acquainted with measures to prevent accidents and first aid measures in case of such accidental happenings. Different dangers surrounding a lab technician in a laboratory are due to a) Acids and alkalies b) Toxic, harmful and irritating chemicals c) Oxidising chemicals d) Carcinogenic chemicals e) Infectious specimens and materials f) Glass ware g) Heat h) Fire i) Explosion j) Electrical shock.

Cautiousness and alertness are requisite qualities if one has to safeguard oneself and fellow technicians.

Essay Questions

1. What are different accidents possible in a laboratory? Write about preventive and first aid measures for corrosives.
2. Write about the storage aspects of different chemicals capable of causing accidents. Write about Toxic, harmful and irritating chemicals.
3. Classify burns. Mention the accidental conditions causing burns. Write about first aid measures.
4. Write about infectious specimens and materials.
5. Write about electric shock and electrical short circuiting.

Short Questions

1. Mention different corrosive substances used in a laboratory.
2. What are different possible bodily damages by acids and alkalies?
3. What are the precautions for preventing spilling of acid splashes on the skin?
4. Write about first aid in case of spilling of acid splashes on the skin.
5. How do you dilute a concentrated acid safely?
6. Mention different substances used in the first aid of alkali caused accidental conditions.

7. How do you prevent accidental swallowing of acids and alkalies?
8. Give examples of toxic, harmful and irritating chemicals.
9. How do you safely handle oxidising chemicals?
10. Write the safety procedure followed in case of contact of carcinogenic chemicals with skin.
11. What is the first aid followed in accidental swallowing or sucking of infectious specimens into mouth?
12. Suggest the type of glassware to prevent injury by glassware.
13. Define inflammable liquids and give examples of inflammable liquids.
14. Write about fire escape.
15. How do you store picric acid?
16. Mention the preventive steps of electrical shock.
17. How do you tackle electrical short circuiting?
18. Mention the causes of electric shock in a laboratory.

8. COLLECTION OF SPECIMENS

i) Blood : Types of specimens, collection, precautions during collection, processing and preservation

Specimens of blood are required to be collected for different diagnostic tests. These tests include haematological, biochemical, microbiological, serological aspects of diagnosis.

Types of Blood Specimens :

1. Random specimen
2. Fasting specimen

Random Specimen : Random specimen is one which is collected at any time without any specific instructions to be followed by the patient before the collection.

Fasting Specimen : Fasting blood specimen is one which is collected in the morning after a night's fasting (12-16 hours).

Post prandial specimen is collected 2 hours after taking lunch. Post glucose samples is collected after giving glucose to a fasting patient. Glucose tolerance test requires post prandial, post glucose specimens.

Forms of blood used in diagnostic tests.

Blood is used for diagnostic testing in the forms of

1. Whole blood
2. Plasma
3. Serum
4. Cellular part

Reasons for choice of a form of blood :

Choice of a form depends on the substance being determined.

Whole blood or plasma is generally used when the substance being determined is uniformly distributed between cells and fluid. Whole blood is used if the test can be done with less quantity of blood- 0.2 ml. or less of capillary blood.

Plasma or serum can be chosen when interference by cellular components has to be avoided. Ex: Determination of glucose, uric acid, creatinine etc. When concentrations of components vary from cells to plasma as in the case of inorganic ions, serum or plasma can be used.

Serum rather than plasma is preferable when it is necessary to separate the cells free from haemolysis.

Plasma is used when determination is urgent and also when plasma specific component is to be determined. Ex: Fibrinogen

Cellular part may be required in some cases.

Uses of different forms of blood:

1. Whole blood: It is used in blood cells total and differential counts, haemoglobin estimation, pH, lead, NPN etc.
2. Serum : Amino acids, Free and esterified cholesterol, creatinine, copper, Iron, enzymes etc.
3. Plasma : Fibrinogen, Ascorbic acid, bicarbonate, chloride etc.
4. Cellular part : Glucose - 6PD, abnormal haemoglobins etc.

Different routes of blood collection:

1. Capillary route
2. Venous route
3. Arterial route

Types of blood specimens on the basis of routes of blood collection:

1. Capillary blood : Blood collected from capillaries.
2. Venous blood : Blood collected from veins.
3. Arterial blood : Blood collected from arteries.

Capillary blood or venous specimens are used for almost all determinations with blood. Venous and arterial blood are similar in composition except for a few differences such as O₂ / CO₂ tension. Capillary route is usually used when small volume of blood i.e. 0.2 ml. or less is needed. Venous blood is collected when more blood is needed.

Collection of capillary blood specimen :

Capillary blood is used when small volume of blood is needed. It is used in

blood cell counting procedures, haemoglobin estimation, blood grouping, bleeding time, clotting time etc.

Quantity of blood collected by capillary route :

Volumes upto 0.2 ml. can be collected. A skilled technician can obtain upto 1 ml. Amounts upto 3 ml. can be collected by repeated expressions.

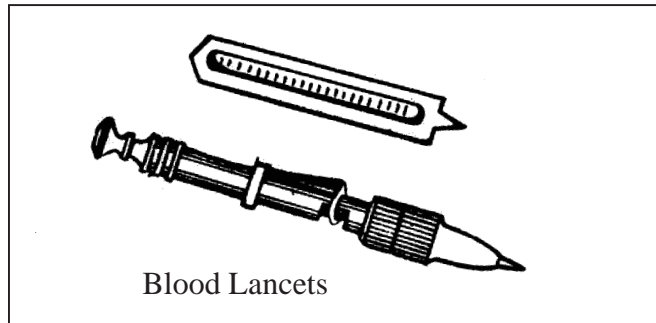

Sites of collection of capillary blood specimen:



1. Tip of a finger
2. Thumb
3. Lobe of an ear or great toe
4. Heel for infants

Requirements :

1. Surgical needle or disposable hypodermic sterile needle or lancet.
2. Cotton
3. Spirit or povidone Iodine (for leukaemic patients)
4. Thin tourniquet.
5. Blood pipettes or slides or small tubes (with or without anticoagulant)

Procedure :

1. Warm the site of collection by massaging.
2. Clean with cotton dipped in spirit or ether.
3. Allow spirit to evaporate completely.
4. Prick smartly.
5. Wrap a thin tourniquet at the base of the finger, if felt necessary.
6. Collect into a blood pipette or over to a slide. If more volume of blood is required, collect in to a small tube with or without anticoagulant.

Precautions : 1. Pipettes used should be clean and dry. Clean and dry pipettes ensure filling with ease. Cleaning of pipettes can be done by washing in chromic acid, washing with water, drying with acetone.

2. It is not desirable to exert undue pressure in case of effect on concentration of blood.

Collection of Venous blood specimen:

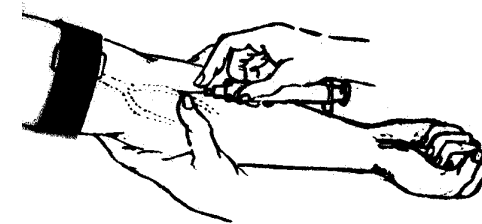

When specimen of blood in volume more than capillary blood is required, venous route is chosen. Venous blood is collected for determinations like E.S.R., Blood sugar, Serum cholesterol, Blood urea etc.

Quantity of blood collected by venous route :

Upto 10 ml. of blood sample is collected by this route. If a number of determinations are to be done, upto 20 ml. of blood can be collected.

Sites of collection of venous blood :

1. Vein on the front of elbow :
2. Vein on the fore arm

- 3. Vein on the ankle
 - 4. Vein on the foot
- } These sites shall not be used in diabetics and patients with CVS disorders.

Requirements :

- 1. Rubber tourniquet or cuff of a sphygmomanometer.
- 2. Sterile syringe with sterile hypodermic needle or disposable syringe with disposable needle (gauge of needle should be less than 22 and 1 to 1 1/2 inches long.).
- 3. Spirit or Ether
- 4. Cotton
- 5. Tubes with or without anticoagulant

Procedure :

- 1) Extend the arm of the patient.
- 2) Apply a tourniquet firmly a few inches above the elbow. This should not obliterate arterial pulse at the wrist.
- 3. Clean the site of collection with cotton soaked in spirit and allow to evaporate.
- 4. Taking the arm of the patient into grip with one hand and holding the skin at the site of collection with the thumb of another hand, penetrate the needle into vein by positioning the needle at 30° to 40° angle.
- 5. When the needle enters into the vein, withdraw the plunger slightly. Penetration into the vein can be felt by relaxation of initially felt resistance.
- 6. Release the tourniquet when blood appears in the barrel. This minimises congestion.
- 7. Place a pad of cotton wool soaked in spirit on the site of insertion of needle into the vein after drawing desired quantity of blood and withdraw the needle.

- 8. Hold firmly for a few minutes until bleeding stops.
- 9. Remove the needle from the syringe and transfer the collected blood into appropriate container.

Precautions :

- 1) Avoid healed burn areas.
- 2) Avoid the area of haematoma.
- 3) Take care to prevent haematoma.
- 4) Take steps to avoid haemolysis.
- 5) Follow the useful techniques when a patient with difficult veins is to be handled.

Preventing Haematoma :

Haematoma can be prevented by

- 1) Puncturing the upper wall of the vein only.
- 2) Release of tourniquet before removing the needle.
- 3) Use of major veins.
- 4) Applying small amount of pressure at the site of collection after withdrawal of blood.

Handling a patient with difficult veins.

- 1) Feel for a fullest vein using tip of the finger.
- 2) Try other arm.
- 3) Instruct the patient to make a fist
- 4) Massage the arm from wrist to elbow.

Collection of Arterial blood specimen:

Arterial blood specimen is rarely examined.

Sites of collection of arterial blood specimen:

- 1) Radial artery
- 2) Brachial artery
- 3) Femoral artery

Arterial blood specimen is collected for blood gas concentrations determination. It is also required for arterial / venous ratio of blood sugar. Arteries are not superficially situated as the veins are. Arterial blood collection is painful and requires skill. It has to be performed under local anaesthesia.

Novel blood collection systems :

1. Venules
2. Vacutainers

1. Venules: Venules are one of the single use type novel blood collection systems working by negative pressure. Venules with or without anticoagulant are available. Venule is a sterile needle covered with a glass tube. It is also supplied with a small file to break the glass tube. Venules for variety of purposes are available.

Procedure of collection : Break the glass tube with the file supplied. Insert the needle into the vein. By manipulating the tube, open the valve in the rubber stopper. Blood collects into the tube by the negative pressure present inside. If the venule is an anticoagulated one, rotate the venule between the palms of the hands to cause proper mixing of blood and anticoagulant.

Vacutainers : Vacutainers are another novel system of blood collection by negative pressure. They are of single use type. Vacutainers for variety of purposes with or without anticoagulant are available.

Description : Different parts of a vacutainer are

1. Disposable needle
2. Holder
3. Evacuated glass tube

When needle is inserted at the site of collection, rear cannula punctures the rubber stopper. Blood fills by negative pressure.

Processing of blood specimens : After collection, blood specimens are

processed to different forms such as whole blood, serum, plasma and cells for their subsequent use in determinations. Protein precipitation is needed when proteins can cause interference in determinations. When whole blood is required for determination, anticoagulant is required to be mixed with blood for preventing clotting of blood. When serum is required, anticoagulant need not be added. When plasma cells are needed, anticoagulant has to be added to prevent clotting of blood. Serum and plasma cells have to be separated by centrifugation.

Requirements for blood processing:

1. Anti coagulants.
2. Tubes / Centrifuge tubes / venules / bulbes vacutainers with or without anticoagulant.
3. Centrifuges

1. Anticoagulant : Anti coagulants are the chemical substances which prevent clotting of blood. They are mixed with blood when whole blood and plasma/ cells are required for determinations. Examples of different anticoagulants / mixtures are Heparin, Potassium or sodium oxalate,

Double oxalate, Sodium citrate, Ethylene diamine tetra acetic acid (EDTA), Sodium fluoride, Acid citrate dextrose (ACD) etc. Double oxalate is a mixture of 3 parts of ammonium oxalate and 2 parts of potassium oxalate.

Anticoagulated bulbs can be prepared. If venules or vacutainers are used for collection, the appropriate variety containing or not containing the anticoagulant can be used.

2. Tubes/Bulbs: They are used for collection of blood. Blood is taken in to the tubes, mixed with appropriate quantity of anti coagulant if whole blood /plasma/cellular part is needed. In case, venules or vacutainers are used for collection ,they may or may not contain anticoagulant. Anticoagulant is mixed or not mixed as per the requirement For serum, anticoagulant is not needed.

3. Centrifuge : Centrifugation requires centrifuges. Centrifugation is necessary for separation of plasma from anticoagulated blood, separation of serum from clotted blood and for cells also.

Procedure :

Processing of blood specimen for whole blood : When whole blood is required for determinations, anticoagulant should be added. This can be done by taking appropriate quantities of anticoagulant in the tube, transferring blood into the tube and mixing. Bulbs with anticoagulants also may be used for this purpose. Venules or Vacutainer with anticoagulant also may be used. Choice of anticoagulant depends also on the constituent to be determined. For example, oxalated./ EDTA added /citrate plasma shall not be used for calcium determinations since oxalates, citrate and EDTA are acting as anticoagulants by virtue of their effect on Ca in blood. Hence it will have effect on determination of the constituent also.

Processing of blood specimens for Serum :

When serum is required for determinations, anticoagulants shall not be mixed to allow clotting. After clotting takes place, loosen the clot slowly and centrifuge to separate serum from the clotted blood. Use a pasteur pipette to transfer serum into another clean & dry test tube or bulb. Serum separating vacutainers contain clot activating material due to which, time of centrifugation is lessened. A gel is formed as barrier between clot and serum.

Time of centrifugation is 15-30 minutes. When clot activating material is contained in the collection tube, time of centrifugation is reduced to 10-15 minutes.

Processing of blood specimen for plasma and cellular part :

For both of these forms, an anticoagulant is needed as in the case of whole blood to prevent clotting of blood. Centrifugation of the anticoagulated blood separates plasma and cellular parts of whole blood.

Differences between plasma and serum :

<u>Plasma</u>	<u>Serum</u>
1. Plasma is the supernatant fluid collected after sedimentation of cells from blood	1. Serum is the supernatant fluid collected after retraction of clotted blood
2. Plasma contains anticoagulant since it is added in the processing.	2. Serum does not contain anticoagulant.
3. Plasma contains fibrinogen.	3. Serum does not contain fibrinogen.

Precipitation of Proteins : Proteins have to be removed in the first stage in majority of determinations made on blood. Protein precipitation is done by agents known as protein precipitants.

Ex. Tungstic acid, Trichloroacetic acid, Alkaline zinc sulphate solution, Cadmium sulphate and Barium hydroxide, Organic solvents.

Preparation of protein free filtrate :

Principle : Tungstic acid is a protein precipitant. Tungstic acid formed by reaction between 10% sodium tungstate and 2/3 N H₂SO₄ precipitates proteins which are removed by filtration.

Requirements :

- | | |
|-------------------------|-------------------------|
| 1. Test tube | 2. Serum or Blood |
| 3. Distilled water | 4. 10% Sodium tungstate |
| 5. 2/3 N sulphuric acid | 6. Centrifuge |

Procedure :

1. Measure 2 ml. of blood or serum into a test tube.
2. Add 4 ml. of distilled water.
3. Mix 1 ml. of sodium tungstate (10% w/w) solution and 1 ml. of 2/3 N H₂SO₄
4. Centrifuge and separate supernatant.

Effects of haemolysis :

Haemolysis means destruction of R.B.C. Haemolysis causes certain changes in the composition of the specimen. This is due to the cellular components coming out due to destruction of cell walls of RBC. There are number of constituents of blood in the determination of which, cellular components behave in similar way as the substances being determined. For example glucose, uric acid, creatinine determinations. Concentrations of inorganic constituents vary from intracellular to extra cellular compartments. Haemolysis causes variations in the extracellular compartment and affects results of analysis. In the case of some enzymes, Intra cellular concentration is much more than extra cellular concentration and hence in such cases, haemolysis affects the results.

Measures to prevent haemolysis : Certain precautionary measures have to be followed to prevent haemolysis in the specimens.

1. Collection tubes must be clean and dry.
2. During collection, minimum amount of constriction should be applied to the arm.
3. Blood should be steadily collected into the collection tubes after removing the needle.
4. During collection of serum, Clot should be loosened with a thin, clean and dry glass rod.
5. Anticoagulant should be added by gentle rotation.
6. Speed of centrifugation has to be controlled.

Preservation of blood specimens :

Certain changes take place if blood specimens are kept. Preservation is the process of prevention of such changes during keeping. If blood is to be kept, it should be collected under aseptic conditions. Serum or plasma have to be separated as soon as possible after collection and kept in refrigerator. Temperature range is 2-8°C or 2-4 °C. This will prevent bacterial growth and hence formation of Ammonia. As preservative for blood sugar determination, a mixture of 3 parts of potassium oxalate and one part of sodium flouride can be used. Sodium flouride can interfere in glucose oxidase methods.

Effects of keeping blood and prevention :

1. Loss of CO₂ : Since CO₂ content of plasma is higher than air, it is lost from plasma to atmosphere. It is prevented by collection of blood under liquid paraffin.
2. Glycolysis : Glycolysis is conversion of glucose to lactic acid. Mixture of 3 parts of potassium oxalate and one part of sodium flouride can prevent glycolysis for 2-3 days. However sodium flouride affects GOD methods. Blood placed in isotonic sodium sulphate- copper sulphate solution will prevent glycolysis at least for 2 days.
3. Increase in plasma inorganic phosphate can be prevented by separation of serum or plasma shortly after collection of blood.
4. Since 4°C causes diffusion of potassium through red cell envelope, for estimation of this component, room temperature is better for preservation than refrigeration.
5. Conversion of pyruvate into lactate can be prevented by protein precipitation.

Hence preservation of the blood specimen is dependent on

1. Constituent to be determined.
2. Method to be followed.
3. Temperature of preservation.

ii. Urine : Types of specimens, collection of 24 hrs. urine and preservation.

Single Specimen : Urine specimen collected any time randomly is called as single specimen. It is useful for qualitative analysis.

Receptacle used: Receptacle used for collection is a clean and dry widemouthed glass or plastic bottle with screw cap top.

Procedure :

1. Instruct the patient to let off the initial portion and to collect mid stream portion directly into the container.
2. For children,fasten a plastic bag so that the child passes directly into plastic bag.
3. For bacteriological examination in case of women, collect catheter specimen.

4. For bacteriological examination in case of men, after washing the urethral orifice with antiseptic solution, midstream urine has to be collected in a sterile container.
5. For fasting urine specimen, after a night fasting (12-16 hrs.), morning specimen has to be collected.
6. For post prandial specimen, urine passed 2 hrs. after lunch or dinner has to be collected.
7. For post glucose specimen in G.T.T., specimen has to be collected at different intervals after giving glucose.
8. Label the bottle with patient's name, o.p or i.p number etc.
9. Keep in a refrigerator or add a preservative if urine has to be kept for some time.

24 hrs. urine specimen : Specimen of urine collected in a period of 24 hours duration is called as 24 hrs. urine specimen. It is required in quantitative determinations. A big container is required for collection. Preservative is needed to prevent any changes. Sometime, say 8 A.M. has to be selected in the morning. At that time bladder has to be emptied and urine passed has to be discarded. Subsequently passed urine specimens up to same time in the next morning have to be collected. Container has to be covered and kept in a cool place during this period.

Preservation : Freshly passed urine has to be examined. On standing, chemical changes take place. Bacterial growth also further causes chemical changes. If urine is to be kept prior to examination, it has to be stored at 2-8°C in refrigerator.

Different urinary preservatives are...

1. Conc. HCl
2. 2N HCl
3. Acetic acid
4. Metaphosphoric acid
5. Formalin
6. Boric acid
7. Thymol
8. Toluol
9. Chloroform

Disposal of (lab waste) specimens : Different methods of disposal 1. Disinfection 2. Incineration 3. Autoclaving.

Disposal of specimens (lab waste) is an important aspect to prevent unhygienic

condition and transmission of diseases. Specimens have to be disinfected by suitable method, discarded and containers have to be washed, cleaned and dried. Infectious material can be disposed in paper or cardboard papers and incinerated. Glasware with infective material can be autoclaved. After this, it can be washed, cleaned and dried usually.

SUMMARY

Blood specimens are required for different diagnostic tests. Different types of blood specimen are 1) Random specimen 2) Fasting specimen. Different forms of blood used in testing are whole blood, plasma, serum and cellular part. Blood is collected from capillary route, venous route and arterial route. Novel blood collection systems are venules and vacutainers. Venule is a sterile needle covered with glass tube. Vacutainer is another type of novel collection system for blood which collects blood by negative pressure. After collection of blood, it is processed into the form in which it is to be tested. Anticoagulants are the substances which prevent clotting of blood. Protein free blood filtrate is the part of blood after precipitation of proteins by protein precipitants. Various transport media like amies transport medium and Cary-Blair transport medium are used for transportation of blood specimens. Time of transportation with amies transport medium is below 24 hrs. Preservation of blood specimens is usually done by refrigerating at 2-8°C or 2-4°C. Different types of urine specimens are single specimen and 24 hrs. urine specimen. Disposal of lab waste can be done after disinfection.

Essay Questions

1. Write about different types of blood specimens. What are different forms of blood used in diagnostic testing? Mention their uses.
2. What are different routes of blood collection? Write about collection of venous blood in detail.
3. Write about novel blood collection systems.
4. Write about processing of blood specimens.
5. What are effects of Haemolysis? Discuss the measures to prevent haemolysis.

6. How do you preserve blood specimens?
7. Discuss different aspects of collection of different types of urine specimens.

Short Questions

1. Mention different blood specimens.
2. What is a fasting specimen?
3. What do you mean by post prandial specimen?
4. Define a) plasma b) serum.
5. When do you prefer to chose whole blood for a determination?
6. When do you chose to use blood in the form of plasma or serum?
7. Why do you prefer to chose serum rather than plasma in some determinations?
8. Exemplify determinations in which whole blood is used.
9. When shall plasma be chosen to be used?
10. Give examples of determinations in which serum is used.
11. What are uses of plasma?
12. Where do you find application of blood in the form of cells?
13. Mention different routes of blood collection.
14. Mention some applications of capillary blood.
15. what are the different sites of capillary blood collection?
16. What is the quantity of blood collected by capillary route?
17. How much quantity of blood is collected by venous route for determinations?
18. What are different sites of venous blood collection?
19. What is the angle of insertion of needle into a vein?
20. How do you prevent haematoma during collection of venous blood?
21. How do you handle a patient with difficult veins?
22. What are the different arteries used for blood collection?

23. What are the applications of arterial blood?
24. What is a) Venule b) Vacutainer?
25. Define anticoagulant
26. Give examples of anticoagulants.
27. Mention the anticoagulants not to be used in calcium determination.
28. Differentiate between serum and plasma.
29. Give examples of protein precipitants.
30. Exemplify transport media.
31. What is haemolysis?
32. How do you prevent loss of CO₂ from blood specimen?
33. What is glycolysis?
34. How do you prevent glycolysis?
35. What is single specimen of urine?
36. What is 24 hrs. urine specimen?

9. URINE BIO-CHEMICAL PARAMETERS

Urine glucose : Small amount of glucose (2-20mg) may be present in fasting urine which can not be detectable by chemical methods.

Urine Protein : Quantities not detectable by chemical methods are present in urine of normal individuals.

Urine creatinine : Normal urinary excretion of creatinine is 1.5 to 3.0 g per 24 hours

Urine Urea : Normal urine urea excretion per 24 hours is 10-15 g.

Urine Uric Acid : Normal uric acid excretion per 24 hours is 0.6 to 1 g.

Urine Sodium : Average value of sodium excreted in 24 hours urine is 120 meq/L.

Urine Potassium : Average value of Potassium excreted in 24 hours urine is 40 meq/L.

Urine Calcium : Excretion of calcium in urine over 24 hours period is 50-150 meq (100-300 mg.).

Urine inorganic Phosphorous :

Average excretion of phosphorous in 24 hours is about 1 g.

Urine Chloride : Average value of chlorides excreted in 24 hours urine is 120-250 meq/L.

Conditions of deviations of biochemical parameters :

Urine Glucose : Condition of presence of chemically detectable quantities of glucose in urine is called as glycosuria. Glycosuria occurs in Hyperglycaemia with values above renal threshold. Hyperglycaemia with Glycosuria is present in Diabetes mellitus, other endocrine disorders, pancreatic disorders etc.

Urine Proteins : When chemically detectable quantities of proteins are present in urine, the condition is called as Albuminuria. Proteins are filtered through glomeruli in kidney diseases due to altered glomerular permeability.

Conditions causing Albuminuria are of three types:

- 1) Pre renal conditions - dehydration, heart diseases etc.
- 2) Renal conditions : All forms of renal diseases.

3) Post renal conditions - Lesions of pelvis, bladder, prostate & urethra etc.

Urinary amylase : High values are observed in acute pancreatitis, carcinoma of pancreas, mumps and renal failure.

Urine creatinine : Excretion rate decreases in all kinds of renal diseases and post renal conditions.

Urine urea : Urea excretion is decreased in pre renal, renal and post renal conditions, pre renal conditions are diabetes mellitus, dehydration, cardiac failure, burns, high fever etc. Renal conditions are kidney diseases. Postrenal conditions are prostate enlargement etc.

Urine Uric acid : High uric acid is excreted in Gout and leukaemia.

Urine sodium : Potassium and chloride excretion of potassium in urine is found in fever, acidosis. In Addison's disease, potassium is retained and sodium chloride is excreted. In Cushing's syndrome, sodium chloride is retained and potassium is excreted. Sodium chloride is excessively lost in salt losing nephritis. Excretion of chlorides is decreased in some types of fevers, chronic nephritis etc.

Urine Calcium : Excretion of calcium in urine is low in rickets. It is high in hyperparathyroidism and hyper thyroidism. In multiple myeloma, it is high. It is frequent in renal stones.

Urine inorganic phosphorous :

Excretion is increased in hyperparathyroidism. Excretion is decreased in hypoparathyroidism and rickets.

Determinations of Biochemical parameters :

Determination of urine sugar : Urine sugar is determined by Benedict's quantitative method and colorimetric methods.

Benedict's Quantitative method :

It is a quantitative method of determination of glucose.

Requirements : 1) Benedict's quantitative solution. 2) Flask 3) Sodium Carbonate 4) Glass beads 5) Burette 6) Bunsen Burner.

Composition of Benedict's quantitative reagent :

Copper sulphate - 18 g.

Sodium Carbonate anhydrous - 100 g.

Sodium citrate - 200 g.
Potassium thiocyanate - 125 g.
5% potassium ferrocyanide solution - 5 ml.
Distilled water to 1000 ml.

Method of Preparation :

- 1) Weigh accurately the substances, calculating for the volume desired to prepare.
- 2) Dissolve carbonate, citrate and thiocyanate in about 100 ml. of distilled water. Heat and filter if necessary.
- 3) Dissolve copper sulphate in about 100 ml. of distilled water taken in another flask or beaker.
- 4) Pour the solution made in step-3 into the solution made in step-2 with stirring with washings.
- 5) Transfer the solution made in step-4 into a 1000 ml. volumetric flask and add 5 ml. of 5% w/v solution of potassium ferro cyanide.
- 6) Dilute to 1 litre with distilled water and filter. Transfer to a reagent bottle. Label neatly and stopper.

Procedure :

- 1) Take 25 ml. of Benedict's quantitative reagent in a flask.
- 2) Add 2g. of Na_2CO_3 .
- 3) Place few glass beads in the flask and boil the reagent.
- 4) Titrate the boiling reagent with urine from a burette until green colour of the reagent disappears. Note the reading.
- 5) Dilute if sugar quantity is very high.
- 6) Calculate the quantity of glucose with formula.

Sugar in mg% = $10 \times 10/\text{ml}$. of urine used.

Colometric methods : Refer to Diagnostic tests.

Determination of urine proteins : Proteins in urine are quantitatively determined by

- 1) Esbach's albuminometer method
- 2) Turbidimetric method

Esbach's Albumino meter method:

Principle : Proteins are subjected to coagulation by the action of picric acid and citric acid.

Requirements : 1) Esbach's reagent(s) 33% Acetic acid.
2. Esbach's albuminometer.

Esbach reagent's Composition : Picric acid 1 g, Citric acid 2 g.

Distilled water up to 100 ml.

Procedure : 1. Acidify urine if it is alkaline or neutral.

2) Take urine in Esbach's albumino meter tube upto "U" mark.

3) Add Esbach reagent upto "R" mark and cork.

4) Mix and allow to stand for 24 hours, keeping the tube vertical.

5) Take the reading on the tube, which gives amount of dry proteins per litre of urine.

Note : Dilution of urine is needed when specific gravity of urine is more than 1.010.

Turbidimetric procedure :

It provides accurate estimation. Turbidity produced by test is compared with standard in this method.

Clinical significance :

Chemically detectable quantities of proteins are not found in urine of normally healthy individuals. In the process of glomerular filtration taking place at the glomeruli, only small quantity of low molecular weight proteins pass into the glomerular filtrate. Higher molecular weight proteins such as albumin and gamma globulin are not filtered at glomeruli. In the process of tubular reabsorption, taking place in the tubules, most of the protein is reabsorbed. However, Tamm-Horsfall protein, a mucoprotein secreted by renal tubules appears in urine, on the whole, <150 mg. of protein per 24 hours is generally excreted, which is not detectable by qualitative / semi quantitative testing procedures.

Urine Amylase : Determination of urinary amylase is useful in assessment of serum amylase. Correlation exists in normal kidney functioning cases.

Principle : Determination of amylase is based on its ability to hydrolyse starch.

Sample : Urine diluted with distilled water.

Requirements : 1) Test Tubes

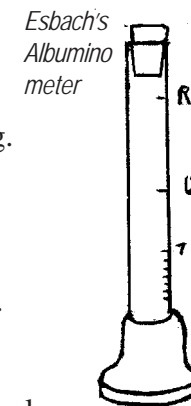

- 2) Serological Pipettes
- 3) Thermostatic water bath
- 4) Photoelectric colorimeter

Reagents :
 1) Buffered substrate
 2) Stock colour reagent

Buffered Substrate :

Composition : Anhydrous disodium hydrogen phosphate - 2.66 g.
 Benzoic acid - 0.86 g
 Starch - 0.04 g
 Distilled water 100 ml.

Preparation : Dissolve anhydrous disodium hydrogen phosphate, Benzoic acid and Starch in distilled water .

Storage : 2-8°C stability : 3 months

Stock colour reagent :

Composition : Potassium Iodate - 0.3567 g
 Potassium Iodide - 4.5 g
 Concentrated Hydrochloric acid 0.9 ml.
 Distilled water 100 ml.

Preparation :

Dissolve Potassium Iodate, Potassium Iodide and Concentrated HCl , in Distilled water.

Storage : 2-8°C stability : 1 year

Working Colour reagent:

Dilute stock colour reagent 10 times with distilled water

Procedure :

- 1) Take two test tubes and label them as control and test
- 2) In one test tube, label as test take 2.5 ml. of buffered substrate incubate for 5 minutes at 37°C. Add 0.1 ml. of serum, incubate 37°C for 7.5 minutes, mix 20 ml. of distilled water and add 2.5 ml. of working colour reagent.
- 3) In another test tube, take 2.5 ml. of buffered substrate, incubate at 37°C for

5 minutes, add 2.5 ml. of working colour reagent and 20 ml. of distilled water.

- 4) Read intensities at 660 nm wave length.

Calculation :

$$\text{Urinary amylase} = \frac{\text{control} - \text{Test}}{\text{control}} \times 400 \times \text{dilution factor}$$

Determination of urine creatinine :

Method : Alkaline picrate method :

Principle : Same as for serum creatinine by Alkaline picrate method.

Requirements :

Same as for serum creatinine by Alkaline picrate method and additional reagent - 3% w/v sulphosalicylic acid.

Procedure :

- 1) Pipette out 5 ml. of urine into a test tube
- 2) Add 2-3 drops of 3% sulphosalicylic acid
- 3) If turbidity is observed, deproteinise by adding 8 ml. of distilled water to 1 ml. of urine followed by 0.5 ml. of 2/3 N sulphuric acid, 0.5 ml. of 10% sodium tungstate, centrifuge for 10 minutes and separate supernatant. If urine is not turbid after adding 3% sulphosalicylic acid, dilute 10 times with distilled water.
- 4) Take 3 test tubes and label them as T (Test), S (Standard) and B (Blank).
- 5) Test : Take 4.8 ml. of distilled water, 0.2 ml. deproteinised / diluted urine and 1 ml. of Alkaline picrate reagent in the test tube labelled as 'T'.
- 6) Standard : Take 4.8 ml. of distilled water, 0.2 ml. of 10 mg% standard solution and 1 ml. of Alkaline picrate reagent in the test tube labelled as "S"
- 7) Blank : Take 5 ml. of distilled water and 1 ml. of Alkaline picrate reagent in the test tube labelled as "B".
- 8) Take O.D. readings of T, S against B at 520 nm wave length.
- 9) Calculate the concentration and quantity excreted in 24 hours.

$$\text{Urine Creatinine mg/dL} = \frac{\text{OD of T}}{\text{OD of S}} \times 10 \times \text{dilution factor}$$

Urine creatinine excreted over 24 hours =

$$\frac{\text{Volume of 24 hours urine in ml.} \times \text{urine creatinine concentration}}{100} \text{ mg.}$$

Determination of Urine Urea :

Method : Diacetyl monoxime method

Principle : Same as for serum urea by DAM method.

Requirements : Same as for serum urea by DAM method.

Specimen : 24 hours urine.

Procedure :

- 1) Dilute the urine specimen 10 times with distilled water.
- 2) Take 3 test tubes and label them as T, S and B (Test, Standard and Blank).
- 3) Take 5 ml. of working reagent, 0.05 ml. diluted urine in the tube labelled as 'T'.
- 4) Take 5 ml. working reagent and 0.05 ml. of 20mg/dl standard solution in the tube labelled as 'S'.
- 5) Take 5 ml. of working reagent and 0.05 ml. of distilled water in the tube labelled as 'B'.
- 6) Keep in boiling water bath for 20 minutes, cool and read ODs at 530 nm wave length against blank.

Calculation :

$$\text{Urine urea concentration in mg/dl.} = \frac{\text{OD of T}}{\text{OD of S}} \times 20 \times \text{dilution factor}$$

$$\frac{\text{Urine urea excreted over 24 hours} = \text{Volume of 24 hours urine in ml.} \times \text{urine urea concentration}}{100} \text{ mg.}$$

Urine Uric acid :

Method : Henry and Caraway

Principle : Same as for serum creatinine by Henry caraway method.

Requirements : Same as for serum creatinine by Henry Caraway method

Specimen: 24 hours urine, preserved by thymol crystals.

Procedure:

- 1) Dilute the urine specimen 200 times.

- 2) Dilute the stock uric acid standard solution 200 times.
- 3) Take three test tubes and label them as T, S and B. (Test, Standard and Blank)
- 4) Take 3 ml of dilute urine, 1 ml of 10% Sodium carbonate solution and 1 ml. of dilute phospho tungstic acid reagent in the tube labelled as T and mix.
- 5) Take 3 ml of dilute standard, 1 ml of 10% sodium carbonate solution and 1ml. of dilute phosphotungstic acid in the tube labelled as S and mix.
- 6) Take 3 ml of distilled water, 1 ml. of 10% Sodium carbonate solution and 1 ml of dilute phospho tungstic acid solution in the tube labelled as B and mix.
- 7) Read the intensities at 660 nm wavelength against blank.

Calculation :

$$\text{Concentration of uric acid (mg\%)} = \frac{\text{O.D. of T}}{\text{O.D. of S}} \times 100$$

$$\frac{\text{Quantity of uric acid excreted in 24 hours} = \text{Volume of 24 hours urine in ml.} \times \text{concentration of uric acid in urine}}{100} \text{ mg.}$$

Determination of Urine Sodium and Potassium :

Method : Flame photometric method

Principle : When a specimen is introduced into flame in the form of a fine spray, solvent evaporates and the electrons in atoms of the solute are subjected to excitation. Electrons being unstable in this state emit excess energy in the form of light. Intensity of this emitted light is called as flame emission intensity and this is proportional to the concentration of the element being determined.

Requirements :

- 1) Test tubes
- 2) Volumetric pipette (10ml),
- 3) Bulbs
- 4) 100 mL push button pipette
- 5) Flame photometer

Reagent : 1) Mixed working standards for sodium and potassium (120/2, 140/4, 160/6).

Specimen for sodium : 24 hours urine (undiluted) .

Specimen for potassium : 10 times diluted.

Procedure :

- 1) Dilute the three standards each with 1 ml. of glass distilled water.
- 2) Introduce glass distilled water into the flame of f .p.m.
- 3) Adjust the filter for simultaneous determination of sodium and potassium.
- 4) Introduce glass distilled water and make zero adjustment.
- 5) Introduce the standard solution and record readings.
- 6) Now introduce the specimen and record the readings.

Calculations :

Sodium excreted in 24 hrs. =

$$\frac{\text{Volume of 24 hours urine in ml.} \times \text{urine sodium concentration}}{1000} \text{ meq.}$$

Concentration of potassium in 24 hrs. urine = Reading x 10.

Potassium excreted in 24 hrs. =

$$\frac{\text{Volume of 24 hours urine in ml.} \times \text{urine potassium concentration}}{1000} \text{ meq.}$$

Determination of urine calcium :

Method : Cresol Phthalein Complexone (CPC).

Calcium can be determined by Cresol Phthalein Complexone method and flame photometric method also.

Specimen : 24 hours urine specimen preserved by few thymol crystals.

Requirements : 1) Colorimeter for reading ODs.

Reagents : 1) Calcium reagent-1 2) Calcium reagent-2 3) Calcium Standard.

1) Calcium reagent-1 :

Composition : CPC - 40 mg.
 Conc. HCl - 1 ml.

8-hydroxy quinoline - 2.5 g.

DMSO - 100 ml.

Glass distilled water up to 1 litre.

Method of preparation : Mix 40 mg. of CPC with 1 ml. of conc. HCl. Add 2.5 g of 8-hydroxy quinoline, 100 ml. of DMSO and dilute to 1 litre with glass distilled water.

2) Calcium reagent-2 :

Composition : KCN - 500 mg.

 Diethylamine - 40 ml.

Glass distilled water upto 1 litre.

Method of preparation : Mix 500 mg. of KCN and 40 ml. of diethyl amine to about 750 ml. of glass distilled water and dilute to 1 litre with glass distilled water.

3) Calcium standard (10 mg/dL i.e., 5 meq/L) :

Composition : Calcium carbonate - 25 mg

 50% v/v HCl up to 100 ml.

Method of preparation : Dissolve 25 mg. of Calcium carbonate in 75 ml. of 50% v/v HCl and dilute to 100 ml. with 50% v/v HCl.

Procedure : 1. Take 6 ml. of working reagent made from equal volumes of calcium reagent 1 and 2 and 0.05 ml. of urine in the tube labelled as 'T' and mix thoroughly.

2) Take 6 ml. of working reagent and 0.05 ml. of 10 mg% standard in the tube labelled as "s" and mix throughly.

3) Take 6ml. of distilled water and 0.05 ml. of distilled water and mix throughly in tube labelled as 'B'.

4) After 10 minutes, read intensities against blank at 575 nm wave length.

Calculation:

$$\text{Urine calcium} = \frac{\text{O.D. of T}}{\text{O.D. of S}} \times 10 \text{ mg\%}$$

$$\frac{\text{Quantity of calcium excreted over 24 hours in mg} = 24 \text{ hours urine volume (in ml.)} \times \text{urine calcium (mg\%)} }{100}$$

Determination of Urine inorganic phosphorous :

Method : Gomori's method :

Principle : Acid molybdate reagent reacts with inorganic phosphate to form phosphomolybdic acid. Colour reagent metol reduces phosphomolybdic acid to give blue coloured compound. Intensity of blue colour is proportional to the concentration of inorganic phosphorous.

Requirements :

- 1) Test tubes.
- 2) Centrifuge tubes.
- 3) 1 ml. and 5 ml. pipettes with graduations.
- 4) Photo electric colorimeter.

Reagents :

- 1) 10% Trichloro acetic acid.
- 2) Acid molybdate reagent.
- 3) Colour reagent.
- 4) Phosphorous standard (5 mg%) reagent.

- 1) 10% trichloro acetic acid :

Composition : Trichloro acetic acid - 10 gms.
Distilled water upto 100 ml.

Method of preparation : Dissolve 10 gms. of trichloro acetic acid in 75 ml. of distilled water and diluted to 100 ml. with distilled water.

- 2) Acid molybdate reagent :

Composition : Ammonium molybdate - 5 g.

10N Sulphuric acid - 100 ml.

Distilled water - 300 ml.

Method of preparation :

- 1) Dissolve ammonium molybdate in 10N Sulphuric acid .
- 2) Add the solution prepared in step-1 to 300 ml. of distilled water gradually with constant stirring and cool.
- 3) Colour reagent :

Composition : Metol - 1 g.

3% w/v sodium metabisulphite solution up to 100 ml.

Method of preparation : Dissolve 1 g. of metol in 75 ml. of 3% w/v sodium metabisulphite solution and dilute to 100 ml. with 3% w/v sodium metabisulphite solution.

- 4) Phosphorous standard (5 mg%) reagent :

Composition : Potassium dihydrogen phosphate - 0.2197 g.

Glass distilled water - 1 litre

Method of preparation : Dissolve 0.2197 g. of Potassium dihydrogen phosphate in 1 litre of glass distilled water.

Storage : 1) Store the reagents 1,2 and 3 at room temperature. 2) Store the Phosphorous reagent at 2-8°C.

Specimen : 24 hours urine specimen preserved by thymol crystals.

Procedure :

- 1) Dilute the urine specimen 10 times with 10% TCA. If urine is turbid after adding TCA, centrifuge and separate supernatant.
- 2) Dilute the standard (5mg %) ten times with TCA reagent
- 3) Take 3 test tubes and label them as T, S and B.
- 4) Take 2.5 ml. dilute urine, 0.5ml. molybdate reagent and 0.5 ml. colour reagent in the tube labelled as T.

- 5) Take 2.5 ml. of dilute standard, 0.5 ml. molybdate reagent and 0.5 ml. colour reagent in the tube labelled as "S".
- 6) Take 2.5 ml. of distilled water, 0.5 ml. of molybdate reagent and 0.5 ml. of colour reagent in the tube labelled as "B".

Calculation :

$$\text{Concentration of inorganic phosphorous in urine (mg\%)} = \frac{\text{O.D. of T}}{\text{O.D. of S}} \times 50$$

Quantity of inorganic phosphorous preserved over 24 hours in mg. =

Volume of 24hrs. urine in ml. X Concentration of inorganic phosphorous

100

Determination of Urine Chlorides:

Method : Schales and Schales Titration method

Principle : Chloride ions in urine react with mercuric ions to form soluble non ionised mercuric chloride



Excess mercuric ions react with diphenyl carbazone to give blue violet coloured complex indicating the end point.

Requirements :

- 1) Test tubes
- 2) 0.2 ml., 2 ml pipettes (graduated)

Reagents:

- 1) Mercuric nitrate reagent (0.3%)
- 2) Diphenyl carbazone (100 mg%)
- 3) Chloride standard (100 meq/L)

1) Mercuric nitrate reagent (0.3%) :

Composition : Mercuric nitrate : 3 gms.

2 N Nitric acid : 20 ml.

Distilled water up to 1 litre.

Method of preparation : Dissolve 3 gms. of mercuric nitrate in 750 ml. of distilled water, add 20 ml. 2N nitric acid and dilute to 1 litre with distilled water.

2) Diphenyl carbzone (100 mg%) :

Composition : Diphenyl carbazone - 100 mg.

95% v/v ethanol upto 100 ml.

Method of preparation : Dissolve diphenol carbazone in 75 ml. of 95% v/v ethanol and dilute to 100 ml. with 95% v/v ethanol.

3) Chloride standard (100 meq/L) :

Composition : Sodium Chloride (Analar) - 5.85 gms.

Distilled water upto 1 litre.

Method of preparation : Dissolve 5.8 gms. of Sodium Chloride (Analar) in 750 ml. of distilled water and dilute to 1 litre with distilled water.

Storage : 1) Reagent 1 is stable at room temperature, stored in amber coloured bottle. 2) Indicator is stable at 2-8°C, stored in amber coloured bottle 3) Reagent 3 is stable at 2-8°C.

Specimen : 24 hours urine specimen

Procedure :

- 1) If proteins are present, prepare protein free filtrate of urine by mixing 4 ml. distilled water, 0.5 ml. urine, 0.2 ml. 2/3 N H₂SO₄ and 0.25 ml. 10% sodium tungstate, centrifuging and separating the supernatant.
- 2) Take 2 ml. of supernatant into a test tube and add one drop of Diphenyl carbazone indicator.
- 3) Titrate against mercuric nitrate reagent until blue violet colour is formed.
- 4) Conduct the similar titration with 10 times diluted standard.

Concentration of urine chlorides (meq/L) =

$$\frac{\text{Titration reading with standard}}{\text{Titration reading with urine}} \times 100$$

Quantity of chlorides excreted over 24 hours =

$$\frac{\text{Concentration of urine chlorides (meq/L)} \times \text{Volume of 24 hours urine in ml.}}{1000}$$

24 hours urine collection, preservation and tests done :

24 hours urine specimens are required for quantitative work. This specimen gives average of the concentrations varying with in 24 hours.

Collection of 24 hours urine specimen :

For collection of 24 hours urine specimen, a big receptacle is required. It is necessary to add a preservative to prevent decomposition and contamination.

Requirements :

- 1) Receptacle
- 2) Preservative

Procedure : Some suitable time in the morning has to be chosen. For Ex: If 8 A.M. is selected, at this time, patient has to empty the bladder and this urine should be discarded. All other specimens passed during the day, the following night and the specimen passed in the next morning same time have to be collected. Whenever patient gets the urge to defaecate during this 24 hours duration, this has to be done after emptying the bladder and saving. This is done to prevent loss possible by urine passing during defaecation. In case of loss in such case, specimen will be incomplete. Urine is passed into a clean, well washed and dry container, and kept in a cool place. The receptacle is covered or stoppered. It undergoes little changes. Refrigeration avoids bacterial growth and hence decomposition.

Volume of 24 hours urine specimen :

On an average diet and normal fluid intake, volume of 24 hours urine specimen is between 1.2 to 1.5 litres. It varies both physiologically and pathologically. In polyuria, volume of 24 hrs. urine specimen is more than 2 litres. In Oliguria 24 hours urine volume is reduced below normal i.e. less than 500 ml. In Anuria, there is total suppression of urine.

Preservation :

24 hours urine specimen contains different specimens collected during the

past 24 hours. Urine which is not fresh-undergoes decomposition due to bacterial action.

For 24 hours specimen, preservatives are added.

Different preservatives added are :

- 1) Concentrated HCl - 10 ml.
- 2) 2N concentrated HCl - 50 ml.
- 3) Acetic acid - 10% of the volume of urine collected.
- 4) Metaphosphoric acid - 5% of the volume of urine collected
- 5) Formalin - 1 drop for 30 ml. of urine
- 6) Boric acid - 0.3 g per 120 ml. of urine
- 7) Thymol - few crystals or 5 ml. 10% w/v solution in isopropanol
- 8) Toluol - 2ml per 100 ml. of urine
- 9) Chloroform - 5 ml. per 100 ml. of urine

Disadvantages of preservatives :

1. Toluene and light petroleum form thin layer on the surface.
2. Chloroform will interfere with some tests - ex: detection of glucose. Chloroform also floats.
3. Thymol can interfere with acid precipitation test for protein.
4. If formalin is added in quantity in excess above specification, it will give positive results for tests for glucose.

Tests done with 24 hours urine specimens :

24 hours urine specimen is required for quantitative determinations.

Ex: Determinations of Urea, Ammonia, Total Nitrogen, Calcium, Sodium, Potassium, Chloride, Bicarbonate, Phosphorous, Aminoacids, Creatine, Creatinine, Proteins, Reducing substances, Ketone bodies, Amylase, 17-Ketosteroids etc.

SUMMARY

Determinations of biochemical parameters of urine help in diagnosis of clinical condition. Urine sugar can be quantitatively determined by Benedict's quantitative and colorimetric methods. Urine proteins can be quantitatively

determined by Esbach albuminometer and turbidimetric methods. Urine creatinine can be quantitatively determined by Alkaline picrate method. Urine urea can be determined by DAM method. Urine uric acid can be determined by Henry and Caraway method. Urine Sodium and Potassium can be determined by Flame photometric method. Urine calcium can be determined by CPC method. Urine inorganic phosphorous can be determined by Gomorii method. Urine chlorides can be determined by Schales and schales titration method. 24 hours urine specimen requires addition of preservatives like Toluol, Formalin, Thymol etc.

Essay Questions

1. Mention different biochemical parameters of urine and their normal limits.
2. Write about determination of urine creatinine.
3. Give in detail about determination of urine urea.
4. Write about flame photometric method of determination of urine sodium and potassium.
5. Explain determination of urine inorganic phosphorous.
6. How do you determine urine calcium?

Short Answer Questions

1. Name the methods for estimation of a) Sodium 2) Potassium in urine.
2. Mention different tests done with 24 hrs. urine.
3. Give the concentration of chloride standard in urine chloride determination.
4. Write the methods of a) Urine uric acid b) Urine calcium
5. Write the principle of determination of urine chlorides.
6. Write the composition of chloride standard (100 meq./lit.)
7. Mention the methods of quantitative determination of urine sugar.
8. What are the methods of urine proteins?
9. Name the parameters determined by a) Schales and Schales titration method. b) DAM method.

10 - UNITS OF MEASUREMENTS

Fundamental Quantities:

Physical quantities which are fundamental in nature, which are independent of other quantities are called as fundamental quantities.

Ex: Length, mass, time, thermodynamic temperature etc.

Units: Quantity used as standard of measurement is called as unit.

Fundamental Units :

Units used to measure the fundamental quantities are called fundamental units.

Ex: Centimetre for length in C.G.S. system

Gram for mass in C.G.S. system

Second for time in in C.G.S. system

Derived quantities:

Quantities which are derived from fundamental quantities are called derived quantities.

Ex: Area, Volume, density, work.

Derived units :

Units used to measure derived quantities are called derived units.

Ex: Cm^2 in C.G.S. system for area

Cm^3 in C.G.S. system for volume

gm Cm^{-3} in C.G.S. system for density.

Systems of Units :

There are several systems of units for measurement of fundamental quantities.

1. British system or F.P.S. system
2. Metric system or C.G.S. system
3. M.K.S. system

1. F.P.S. system In British system, units of length, mass and time are Foot (f), pound (p) and second (s) respectively.
2. C.G.S. system : In metric system, units of length mass and time are centimetre (m), gram (gm), and second (s)
3. M.K.S. system : In this system, units of length mass and time are metre(m), kilograms (kg) and second (s). In M.K.S. system current is taken as fourth fundamental quantity and its unit is ampere. Hence this system is also called as M.K.S.A. system.

S.I. Units : It is also called as international system of units.

There are seven fundamental and two supplementary quantities in international system of units.

Fundamental Quantities and their Units in S.I. Units :

Fundamental Quantity	Unit	Symbol
1. Length	Metre	m
2. Mass	Kilogram	Kg
3. Time	Second	S
4. Thermo dynamic temperature	Kelvin	K
5. Lumincus intensity	Candila	Cd
6. Electric current	Ampere	A
7. Quantity of substance	Mole	mol

Supplementary quantities and their units in S.I.

1. Plane angle	Radian	Rad
2. Solid angle	steradian	sr

Some of the derived quantities and their units in S.I.:

1. Area	(meter) ²	m ²
2. Volume	(meter) ³	m ³
3. Density	kilogram/meter ³	Kg m ⁻³
4. Velocity	metre / second	ms ⁻¹

5. Acceleration	metre / second ²	ms ⁻²
6. Momentum	Kilogram metre/second	Kg m s ⁻¹
7. Force	Newton	N
8. Impulse	Newton second	NS
9. Work & Energy	Joule	J
10. Power	Watt	W
11. Pressure	Pascal	Pa
12. Coefficient of viscosity	Poiseuille	Pi
13. Frequency	Hertz	Hz
14. Surface tension	Newton / metre	Nm ⁻¹
15. Specific heat	J / Kg / k	J Kg ⁻¹ k ⁻¹
16. Latent heat	J / Kg	J Kg ⁻¹
17. Wave length	metre	m
18. Wave number	1/metre	m ⁻¹

Definitions of fundamental, supplementary and some derived units of S.I.:

Fundamental units of SI and their definitions :

1. Metre (m) : Metre is the distance travelled by light in vaccum in 1 / 299,792,458th of a second. It is the S.I. unit of length.
2. Kilogram (Kg) : Kilogram is the mass of a cylinder of platinum - Iridium alloy kept at international bureau of weights and measures at paris. It is S.I. unit of mass.
3. Second (S) : Second is the time interval taken by 9, 192, 631, 770 cycles of certain radiation emitted by caesium¹³³ atom in ground state. It is the S.I. unit of time.
4. Kelvin (K) : Kelvin is 1 / 273.16 th of thermodynamic temperature of triple point of water. Kelvin is the S.I. unit of temperature.
5. Candila (Cd) : Candila is the luminous intensity in a direction normal to surface area of 1 / 600000 m² of a black body at the

freezing point of platinum at a pressure of 101325 Nm^{-2} . It is the S.I. unit of luminous intensity.

6. Ampere (A) : Ampere is the current which flowing through in each of two straight parallel conductors of infinite length and negligible cross section placed at a distance of 1 metre apart in vacuum produces a force of 2×10^{-7} newton per metre on each conductor.
7. Mole (mol) : Mole is the amount of substance which contains as many elementary entities (molecules or atom) as there are atoms in 0.0012 Kg of C^{12} .

Supplementary units and their definitions.

1. Radian (rad) : Radian is the angle subtended at the centre of a circle of radius 1 metre by an arc of length 1 metre. It is the S.I. unit of plane angle.
2. Steradian (sr) : Steradian is the angle subtended at the centre of a sphere of radius 1 metre by the surface area of 1m^2 . It is the S.I. unit of solid angle.

Prefixes in S.I. units :

S.No.	Prefix	Power of 10	Symbol
1.	deci	10^{-1}	d
2.	centi	10^{-2}	c
3.	milli	10^{-3}	m
4.	micro	10^{-6}	μ
5.	nano	10^{-9}	n
6.	Pico	10^{-12}	p
7.	Femto	10^{-15}	f
8.	Atto	10^{-18}	a
9.	deca	10^1	da
10.	hecto	10^2	h

11.	kilo	10^3	k
12.	Mega	10^6	M
13.	Giga	10^9	G
14.	Tera	10^{12}	T
15.	Peta	10^{15}	P
16.	Exa	10^{18}	E

Unit of volume in S.I. :

S.I. Unit of volume is 1metre^3 .

Accepted unit of volume is 1 litre.

1 Litre : 1 Litre is the volume occupied by one kilo gram of water at 4°C

1ml : 1 ml is the volume occupied by 1 g of water at 4°C .

Some useful conversions of mass,length and volume :

Mass :

1 Kg = 1000 gm	1 gm = 10^{-3} kg.
1 gm = 1000 mg	1 mg = 10^{-3} g.
1 mg = 1000 μg	1 μg = 10^{-3} mg.
1 μg = 1000 ng	1 ng = 10^{-3} μg .

$$1 \text{ kg} = 10^3 \text{ g.} = 10^6 \text{ mg} = 10^9 \text{ ng}$$

Length :

1 metre = 10^2cm	1cm = 10^{-2} metre.
1 metre = 10^3mm .	1mm = 10^{-3} metre.
1 metre = 10^6 mm	1 mm = 10^{-6} metre.
1 metre = 10^{10}A^0	$1\text{A}^0 = 10^{-10}$ metre = 10^{-8} cm.
1 metre = 10^{11} X-ray units	1 X ray unit = 10^{-11} metre.
1 metre = 10^{15} Fermi	1 Fermi = 10^{-15} m

$$1 \text{ metre} = 10^2 \text{ cm} = 10^3 \text{ mm} = 10^6 \text{ }\mu\text{m} = 10^9 \text{ nm}$$

$$10^{10} \text{ \AA} = 10^{11} \text{ X-ray units} = 10^{15} \text{ Fermi}$$

Volume :

$$1 \text{ Litre} = 1000 \text{ ml.} \quad 1 \text{ ml} = 10^{-3} \text{ Litre}$$

$$1 \text{ ml} = 1000 \text{ mL} \quad 1 \text{ mL} = 10^{-3} \text{ ml.}$$

$$1 \text{ deci litre} = 100 \text{ ml.}$$

Measures of Volume in Imperial System

$$1 \text{ Gallon (C)} = 8 \text{ pints}$$

$$1 \text{ pint (O)} = 20 \text{ fluid ounces}$$

$$1 \text{ fluid ounce (}\overline{3}\text{)} = 8 \text{ fluid drachms}$$

$$1 \text{ fluid drachm (}\mathbf{3}\text{)} = 60 \text{ minims (m)}$$

Conversion with Metric System

$$1 \text{ fluid ounce (}\overline{3}\text{)} = 30 \text{ ml.}$$

$$1 \text{ pint (O)} = 20 \text{ fluid ounces} = 20 \times 30 = 600 \text{ ml.}$$

$$1 \text{ Gallon (C)} = 8 \text{ pints} = 8 \times 20 \times 30 = 4,800 \text{ ml.}$$

SUMMARY

Fundamental quantities are physical quantities which are independent of other quantities. Unit is a standard quantity used for measurement. Derived quantities are derived from fundamental quantities. Different systems of units are British system, Metric system, MKS system and S.I.

Essay Question

1. Write about different systems of units.

Short Answer Questions

1. What are fundamental quantities? Give examples.
2. What are units?
3. Define fundamental units and give examples.
4. Define derived quantities and exemplify.
5. What are derived units and exemplify?
6. What is F.P.S. (British) system?
7. Mention the fundamental quantities and their units in C.G.S. (Metric) system.
8. Write the fundamental quantities and their units in M.K.S. system.
9. Mention the fundamental quantities in international system (S.I.)
10. What are the units of fundamental quantities in S.I.?
11. What are supplementary quantities and their units in international system (S.I.)?
12. Mention any two derived quantities and their units in international system (S.I.).
13. Define "meter".
14. Define "Kilogram".
15. Define "second".
16. Mention the unit of volume in S.I. and define.

11. SOLUTIONS

Solution : It is defined as homogeneous mixture of two or more substances.

Ex: 0.9% Sodium Chloride solution

Solute : Substance present in minor proportion is called as solute.

Ex: Sodium chloride present in 0.9% Sodium Chloride solution

Solvent : Substance present in major quantity is called as solvent.

Ex: Water present in 0.9% Sodium Chloride solution

Different types of solutions :

Based upon the states of matter of solute and solvent, solutions can be classified into

1. Solid in liquid solution : Solid solute dissolved in liquid solvent is called solid in liquid solution.

Ex:: 10% sodium tungstate solution

2. Liquid in liquid solution : Liquid solute dissolved in liquid solvent is called liquid in liquid solution.

Ex: 2% Acetic acid solution

3. Gas in liquid solution : Gaseous solute dissolved in liquid solvent is called gas in liquid solution.

Ex: Aerated water.

4. Solid in solid solution : Solid solute dissolved in solid solvent is called solid in solid solutions.

Ex: Alloys

5. Liquid in solid solution : Liquid solute dissolved in solid solvent is called liquid in solid solution.

Ex: Hydrated salts such as $\text{Na}_2\text{CO}_3 \cdot 10 \text{H}_2\text{O}$

6. Gas in solid solution : Gaseous solute dissolved in solid solvent is called gas in solid solution.

Ex: H_2 in palladium

7. Solid in gas solution : Solid solute dissolved in gaseous solvent is called solid in gas solution.

Ex: Minute particles in inhaled air

8. Liquid in gas solution : Liquid solute dissolved in gaseous solvent is called liquid in gas solution.

Ex: Moisture in air

9. Gas in gas solution : Gaseous solute dissolved in gaseous solvent is called gas in gas solution.

Ex: Air

Methods of expressing Concentration of Solutions :

Different methods of expressing concentration are

- | | | |
|---------------|--------------|-----------------|
| 1. Percentage | 2. Molarity | 3. Normality |
| 4. Molality | 5. Formality | 6. Molefraction |

Types of solutions based on the mode of expression of concentration :

1. Percentage solutions : Solutions whose concentration are expressed as percentage are called as percentage solutions.

2. Molar solutions : Solutions whose concentrations are expressed in terms of molarity are molar solutions.

3. Normal solutions : Solutions whose concentrations are expressed in normality are normal solutions.

4. Molal solutions : Solutions whose concentrations are expressed in molality are molal solutions.

Percentage Solutions :

Solutions whose concentrations are expressed as percentage are called as percentage solutions.

There are four kinds of percentage solutions.

1. Weight in volume percentage solutions (w/v solutions)
2. Weight in weight percentage solutions (w/w solutions)
3. Volume in weight percentage solutions (v/w solutions)
4. Volume in volume percentage solutions (v/v solutions)

Generally w/v solutions and w/w solutions are percentage solutions of solids in liquids.

v/w solutions are percentage solutions of liquids in solids.

v/v solutions are percentage solutions of liquids in liquids.

1. Weight in volume percentage solutions (w/v solutions).

w/v solutions are solutions of solids in liquids, one part of solid solute by weight dissolved in liquid solvent to produce solution of 100 parts by volume is called as 1% weight in volume solution.

General Formula : Solute - 1 g. } will give 1% w/v solution. Solvent up to 100 ml.

Ex: Prepare 200 ml. of 0.9% w/v sodium chloride solution.

100 ml. ----- 0.9 G

200 ml. ----- ?

$$\frac{0.9 \times 200}{100} = 1.8 \text{ G.}$$

1.8 Grams of sodium chloride dissolved in enough water and diluted to 200 ml. with water will produce 200 ml. of 0.9% w/v sodium chloride solution (Normal saline).

Method of Preparation :

1. Weigh accurately 1.8 grams of sodium chloride.
2. Dissolve in about three quarters of the solvent (slightly less than 150 ml. of water).
3. Examine for presence of foreign particles by holding against light. If foreign particles are visible, filter with a plug of cotton wool / filter paper placed in a funnel.
4. Dilute to 200 ml. volume with water in a graduated measuring jar.
5. Transfer into a clean and dry container.
6. Label neatly.

Ex: 2. : Prepare 250 ml. of 10% w/v sodium tungstate solution.

100 ml. ----- 10 grams

250 ml. ----- ?

$$\frac{10 \times 250}{100} = 25 \text{ grams.}$$

25 grams of sodium tungstate dissolved in enough water and diluted to 250 ml. with water will produce 10% w/v sodium tungstate solution.

Method of Preparation :

1. Weigh accurately 25 grams of sodium tungstate.
2. Dissolve in three quarters of the volume of water (approximately 168ml.).
3. Examine for the presence of foreign particles. If foreign particles are visible, filter through a plug of cotton wool / filter paper placed in a funnel.
4. Dilute to 250 ml. with distilled water in a graduated measuring jar.
5. Transfer into a clean and dry container.
6. Label neatly.

Weight in Weight solutions :

W/w solutions are also % solutions of solids in liquids. One part of solid solute by weight dissolved in liquid solvent to produce solution of 100 parts by weight in called as 1% weight in weight solution.

General formula : Solute - 1 g. } will give 1% w/w solution. Solvent up to 100 g.

w/v solutions are more common in application among % solutions of solids in liquids.

Volume in weight solutions (v/w solutions) : v/w solutions are percentage solutions of liquids in solids. One part by volume of liquid solute dissolved in solid to produce solution of 100 parts by weight is called as 1% volume in weight solution.

General formula : Liquid - 1 ml. } will give 1% v/w solution. Solid up to 100 g.

Volume in volume solutions (v/v solutions) :

v/v solutions are percentage solutions of liquids in liquids. One part by volume of liquid solute diluted to 100 parts by volume with liquid solvent is called as 1% volume in volume solution.

General formula : Liquid - 1 ml. } will give 1% v/v solution.
Solvent up to 100 ml.

Ex:1 Prepare 50 ml. of 2% v/v acetic acid

$$\begin{array}{r} 100 \text{ ----- } 2 \\ 50 \text{ ----- } ? \\ \hline 50 \times 2 \\ \hline 100 \end{array} = 1 \text{ ml.}$$

1 ml. of acetic acid diluted to 50 ml. with water will produce 50 ml. of 2% v/v acetic acid solution.

Method of preparation:

1. Take approximately 45 ml. of water into a measuring jar.
2. Add 1 ml. of acetic acid with stirring.
3. Make the volume to 50 ml. with water.
4. Transfer to a clean and dry container.
5. Label neatly.

Ex: 2 Prepare 150 ml. of 10% (v/v) formalin in normal saline.

$$\begin{array}{r} 100 \text{ ----- } 10 \\ 150 \text{ ----- } ? \\ \hline 150 \times 10 \\ \hline 100 \end{array} = 15 \text{ ml.}$$

15 ml. of formalin diluted to 150 ml. with water will produce 150 ml. of 10% v/v formalin.

Method of Preparation :

1. Take 15 ml. of formalin in a measuring jar.
2. Dilute to 150 ml. with water.
3. Transfer into a clean and dry container.
4. Label neatly.

Molar solutions : Molar solution is defined as a solution containing one mole of substance in one litre of solution.

Molarity : Molarity is number of moles of the solute per litre of solution. It is denoted by M.

$$M = \frac{\text{number of moles of solute}}{\text{volume of solution in litres}}$$

Mole : Mole is defined as one gram molecular weight substance present in one litre solution.

Gram molecular weight : Molecular weight expressed in grams is called as gram molecular weight.

Ex: One mole of H₂SO₄ = 98.078 grams of H₂SO₄ in one litre solution.

One mole of HCl = 36.5 grams of HCl in one litre solution.

Method of Preparation of 1 M solution :

1. Weigh accurately quantity equivalent to one gram molecular weight of the substance.
2. Dissolve in approximately 750 ml. of water.
3. Examine for foreign particles and filter if necessary.
4. Dilute to 1 litre with water in a graduated measuring jar.
5. Transfer into a clean and dry container .
6. Label neatly.

Substance	Molecular weight	mass of one mole in one litre ie. Gram molecular weight
H ₂ SO ₄	98.078	98.078 grams
HCl	36.5	36.5 grams

Molarities of commercially available concentrated acids :

Commercially available concentrated hydro-chloric acid has 10.5- 12 M concentration.

Concentrated sulfuric acid is about 18 M.

These two acids are widely used in the preparation of standard solutions of acids.

Problems :

Problem-I :

Prepare 75 ml. of 0.1 M HCl.

Solution : Molecular weight of HCl = 36.5
 Gram molecular weight of HCl = 36.5 g.

i.e. weight of required to make 1 ltr. of 1 M HCl = 36.5 g.

weight of HCl required to make 1 litre 0.1 M HCl =

1 M ----- 36.5 g

0.1 M ----- ?

$$\frac{0.1 \times 36.5}{1} = 3.65 \text{ g.}$$

weight of HCl required to make 75 ml. of 0.1 M solution =

1,000 ml. ----- 3.65 g

75 ml. ----- ?

$$\frac{3.65 \times 75}{1000} = 0.273 \text{ g.}$$

∴ weight of HCl required to make 75 ml. of 0.1 M HCl = 0.273 g.

Method of preparation:

- 1) Take accurately quantity of HCl equal to 0.273 g of HCl.
- 2) Gradually add to about 50 ml. of water with stirring and cool.
- 3) Dilute to 75 ml. with distilled water.
- 4) Standardise and adjust molarity if necessary.

Problem-2 :

Prepare 100 ml. of 0.5 M HCl. with commercially available HCl.

(specific gravity of commercially available HCl = 1.16)

percentage by weight = 36% w/w

Solution : Molecular weight of HCl = 36.5
 Gram molecular weight of HCl = 36.5 g.

i.e., weight of HCl required to make 1 litre of 1 M HCl solution =
36.5 g.

Weight of HCl required to make 1 litre of 0.5M HCl =

1 M ----- 36.5 g

0.5 M ----- ?

$$\frac{0.5 \times 36.5}{1} = 18.25 \text{ g.}$$

Weight of HCl required to make 100 ml. of 0.5 M HCl =

1000 ml. ----- 18.25 g

100 ml. ----- ?

$$\frac{100 \times 18.25}{1000} = 1.825 \text{ g.}$$

Weight of HCl required to make 100 ml. of 0.5 M HCl = 1.825 g.

Quantity of commercially available concentrated HCl required to make

100 ml. of 0.5 M HCl =

percentage by weight of HCl = 36% w/w,

36 g. ----- 100 g

1.825 ----- ?

$$\frac{1.825 \times 100}{36} = 5.07 \text{ g.}$$

specific gravity of HCl = 1.16

1.16 g. ----- 1 ml.

5.07 ----- ?

$$\frac{5.07 \times 1}{1.16} = 4.37 \text{ ml.}$$

∴ Quantity of commercial concentrated HCl required to prepare 100 ml. of 0.5 M HCl = 4.37ml.

Method of Preparation :

- 1) Measure accurately 4.37 ml. of commercial concentrated HCl.
- 2) Gradually add to about 75 ml. of distilled water with stirring and cool.
- 3) Dilute to 100 ml. with distilled water.
- 4) Standardize and adjust molarity if necessary.

Problem - 3 :

Prepare 500 ml. of 0.1M H₂SO₄ solution with commercially available concentrated H₂SO₄ (specific gravity of commercial concentrated H₂SO₄ = 1.84,

percentage by weight = 95% w/w)

Solution : Molecular weight of H₂SO₄ = 98

gram molecular weight of H₂SO₄ = 98 g.

Weight of H₂SO₄ required to make 1 litre of 1 M H₂SO₄ = 98 g.

i.e. Weight of H₂SO₄ required to make 1 litre of 0.1 M H₂SO₄ =

1 M ----- 98 g

0.1 M ----- ?

$$\frac{0.1 \times 98}{1} = 9.8 \text{ g.}$$

Weight of H₂SO₄ required to make 500 ml. of 0.1 M H₂SO₄ = 4.9 g.

Quantity of commercial concentrated H₂SO₄ required to make 500 ml. of 0.1 M H₂SO₄ =

percentage by weight of H₂SO₄ = 95% w/w

95 g. ----- 100 g

4.9 g ----- ?

$$\frac{4.9 \times 100}{95} = 5.16 \text{ g.}$$

Weight of commercial concentrated H₂SO₄ required to make 500 ml. of 0.1 M H₂SO₄ = 5.16g.

specific gravity of H₂SO₄ = 1.84

1.84 g ----- 1 ml.

5.16 g ----- ?

$$\frac{5.16 \times 1}{1.84} = 2.8 \text{ ml.}$$

∴ Quantity of commercial concentrated H₂SO₄ required to make 500 ml. of 0.1 M H₂SO₄ = 2.8ml.

Method of Preparation :

1. Measure accurately 2.8 ml. of commercial concentrated H₂SO₄.
2. Gradually add to about 450 ml. of distilled water with stirring and cool.
3. Dilute to 500 ml. with distilled water .
4. Standardise and adjust molarity if necessary.

Problem - 4 :

Prepare 50 ml. of 1M NaOH

Solution :

Molecular weight of NaOH = 40

Gram molecular weight of NaOH = 40 g.

i.e. Weight of NaOH required to make 1 litre of 1 M NaOH solution=40g.

Weight of NaOH required to make 50 ml. of 1 M NaOH =

$$\begin{array}{r} 1000 \text{ ml.} \text{ ----- } 40 \text{ g.} \\ 50 \text{ ml.} \text{ ----- } ? \\ \hline 50 \times 40 \\ \hline 1000 \end{array} = 2 \text{ g.}$$

Weight of NaOH required to make 50 ml. of 1 M NaOH = 2 g.

Method of Preparation :

1. Weigh accurately 2 g. of NaOH.
2. Dissolve in about 40 ml. of distilled water.
3. Dilute to 50 ml. with distilled water.
4. Standardise and adjust molarity if necessary.

Problem - 5 :

Prepare 500 ml. of 0.2M HCl.

(Molarity of commercially available concentrated HCl = 12 M)

Solution :

Concentration of commercially available concentrated HCl = 12M

Concentration to be prepared by dilution = 0.2 M.

$$\text{Dilution factor} = \frac{\text{Higher concentration}}{\text{Lower concentration}} = \frac{12 \text{ M}}{0.2 \text{ M}} = 60$$

i.e., 1 ml. of 12 M HCl diluted to 60 ml. gives 0.2 M HCl.

Quantity of commercial concentrated HCl required to make 500 ml. of 0.2 M HCl. =

$$\begin{array}{r} 60 \text{ ml.} \text{ ----- } 1 \text{ ml.} \\ 500 \text{ ml.} \text{ ----- } ? \\ \hline 500 \times 1 \\ \hline 60 \end{array} = 8.3 \text{ ml.}$$

Quantity of commercial concentrated HCl required to make 500 ml. of 0.2 M HCl = 8.3ml.

Method of Preparation :

1. Measure accurately 8.3 ml. of commercial concentrated HCl.
2. Gradually add to about 400 ml. of distilled water, mix and cool.
3. Dilute to 500 ml. with distilled water.
4. Standardise and adjust molarity if necessary.

Normal Solutions : Normal solution is defined as a solution containing one equivalent of substance in one litre of solution.

Normality : Normality is defined as number of equivalents of substance per litre of solution. It is denoted by N.

$$N = \frac{\text{Number of equivalents of substance}}{\text{Number of litres of solution}}$$

$$= \frac{\text{Number of milli equivalents of substance}}{\text{Number of millilitres of solution}}$$

Substance	Molecular weight	Gram Molecular weight	Equivalent weight
HCl	36.5	36.5 g	36.5 g.
H ₂ SO ₄	98.078	98.078 g	49.039 g.
NaOH	40	40 g	40 g.

Normalities of commercially available concentrated acids :

Concentrated sulfuric acid is available in approximately 36 N strength.

Concentrated Hydrochloric acid is available in approximately 12 N strength.

Glacial acetic acid is available in approximately 45 N strength.

Problem -1

Prepare 500 ml. of 0.5 N HCl.

Solution : Molecular weight of HCl = 36.5

Gram molecular weight = 36.5 g.

Equivalent weight of HCl = 36.5 g.

i.e., Weight of HCl required to make 1 litre of 1N HCl = 36.5 g.

Weight of HCl required to make 1 litre of 0.5 N HCl =

1 N ----- 36.5 g.

0.5 N ----- ?

$$\frac{0.5 \times 36.5}{1} = 18.25 \text{ g.}$$

Weight of HCl required to make 500 ml. of 0.5 N HCl =

1000 ml. ----- 18.25 g.

500 ml. ----- ?

$$\frac{500 \times 18.25}{1000} = 9.125 \text{ g.}$$

∴ weight of HCl required to make 500 ml. of 0.5 N HCl = 9.125g.

Method of preparation :

1) Take accurately quantity of HCl equivalent to 9.125 g of HCl.

2) Add gradually to approximately 450 ml. of distilled water with constant stirring and cool.

3) Dilute to 500 ml. with distilled water.

4) Standardise and adjust normality if necessary.

Problem - 2

Prepare 200 ml. of 0.5 N H_2SO_4

Solution : Molecular weight of H_2SO_4 = 98

Gram molecular weight of H_2SO_4 = 98 g.

Equivalent weight of H_2SO_4 = 49 g.

Weight of H_2SO_4 required to make 1 litre of 1 N H_2SO_4 = 49 g.

Weight of H_2SO_4 required to make 1 litre of 0.5 N H_2SO_4 =

1 N ----- 49 g.

0.5 N ----- ?

$$\frac{49 \times 0.5}{1} = 24.5 \text{ g.}$$

Weight of H_2SO_4 required to make 200 ml. of 0.5 N H_2SO_4 =

1000 ml. ----- 24.5 g.

200 ml. ----- ?

$$\frac{24.5 \times 200}{1000} = 4.9 \text{ g.}$$

Weight of H_2SO_4 required to make 200 ml. of 0.5 N H_2SO_4 = 4.9 g.

Method of preparation :

1) Weigh accurately quantity of H_2SO_4 equal to 4.9 g. of H_2SO_4 .

2) Add gradually to approximately 175 ml. of distilled water with constant stirring and cool.

3) Dilute to 200 ml. with distilled water.

4) Standardise and adjust normality if necessary.

Problem - 3

Prepare 250 ml. of 0.5 N NaOH

Solution :Molecular weight of NaOH = 40

Gram molecular weight of NaOH = 40 g.

Equivalent weight of NaOH = 40 g.

Weight of NaOH required to make 1 litre of 1 N NaOH = 40 g.

Weight of NaOH required to make 1 litre of 0.5 N NaOH =

$$\begin{array}{r} 1 \text{ N} \text{ ----- } 40 \text{ g.} \\ 0.5 \text{ N} \text{ ----- } ? \\ \hline 0.5 \times 40 \\ 1 \end{array} = 20 \text{ g.}$$

Weight of NaOH required to make 250 ml. of 0.5 N NaOH =

$$\begin{array}{r} 1000 \text{ ml. ----- } 20 \text{ g.} \\ 250 \text{ ml. ----- } ? \\ \hline 250 \times 20 \\ 1000 \end{array} = 5 \text{ g.}$$

Weight of NaOH required to make 250 ml. of 0.5 N NaOH = 5 g.

Method of Preparation :

1. Weigh accurately 5 g. of NaOH.
2. Dissolve in about 200 ml. of distilled water.
3. Dilute to 250 ml. with distilled water.
4. Standardise and adjust normality if necessary.

Problem - 4 :

Prepare 250 ml. of 0.5 N HCl

(specific gravity of commercial concentrated HCl = 1.16, percentage by weight

= 36% w/w)

Solution : Molecular weight of HCl = 36.5

Gram molecular weight of HCl. = 36.5 g.

Equivalent weight of HCl = 36.5 g.

Weight of HCl required to make 1 litre of 1N HCl = 36.5 g.

Weight of HCl required to make 1 litre of 0.5 N HCl =

$$\begin{array}{r} 1\text{N} \text{ ----- } 36.5 \text{ g.} \\ 0.5 \text{ N} \text{ ----- } ? \\ \hline 0.5 \times 36.5 \\ 1 \end{array} = 18.25 \text{ g.}$$

Weight of HCl required to make 250 ml of 0.5 N HCl. =

$$\begin{array}{r} 1000 \text{ ml. ----- } 18.25 \text{ g.} \\ 250 \text{ ml. ----- } ? \\ \hline 250 \times 18.25 \\ 1000 \end{array} = 4.56 \text{ g.}$$

Weight of HCl required to make 250 ml. of 0.5 N HCl = 4.56 g.

Weight of commercial concentrated HCl required to make 250 ml. of 0.5 N HCl = percentage by weight = 36% w/w

$$\begin{array}{r} 36 \text{ g. ----- } 100 \text{ g.} \\ 4.56 \text{ g ----- } ? \\ \hline 4.56 \times 100 \text{ g.} \\ 36 \end{array} = 12.66 \text{ g.}$$

Weight of commercial concentrated HCl required to make 25 ml. of 0.5 N HCl = 12.66 g.

Quantity of commercial concentrated HCl required to make 250 ml. of 0.5 N HCl. =

Specific gravity of HCl = 1.16

1.16 g ----- 1 ml.

12.6 g ----- ?

$$\frac{12.6 \times 1}{1.16} = 10.9 \text{ ml.}$$

Method of Preparation :

1. Measure accurately 10.9 ml. of commercial concentrated HCl.
2. Gradually add to about 190 ml. of distilled water, mix and cool.
3. Dilute to 250 ml. with distilled water.
4. Standardise and adjust normality if necessary.

Problem 5

Prepare 500 ml of 0.5 N H₂SO₄ .

(specific gravity of commercial concentrated H₂SO₄ = 1.84

percentage by weight = 95% w/w)

Solution :

Molecular weight of H₂SO₄ = 98

Gram molecular weight = 98 g.

Equivalent weight = 49 g.

Weight of H₂SO₄ required to make 1 litre of 1 N H₂SO₄ = 49 g.

Weight of H₂SO₄ required to make 1 litre of 0.5 N H₂SO₄ =

1 N ----- 49 g.

0.5 N ----- ?

$$\frac{49 \times 0.5}{1} = 24.5 \text{ g.}$$

Weight of H₂SO₄ required to make 500 ml. of 0.5 N H₂SO₄ =

1000 ml. ----- 24.5 g.

500 ml. ----- ?

$$\frac{500 \times 24.5}{1000} = 12.25 \text{ g.}$$

Quantity of commercial concentrated H₂SO₄ required to make 500 ml. of

0.5 N H₂SO₄ =

percentage by weight = 95% w/w

Weight of commercial concentrated H₂SO₄ required to make 500 ml. of

0.5 N H₂SO₄ =

95 g. ----- 100 g.

12.25 ----- ?

$$\frac{12.25 \times 100}{95} = 12.89 \text{ g.}$$

Weight of commercial concentrated H₂SO₄ required to make 500 ml.

of 0.5 N H₂SO₄ = 12.89 g.

Quantity of commercial concentrated H₂SO₄ required to make 50 ml. of

0.5 N HCl =

Specific gravity of H₂SO₄ = 1.84

1.84 g. ----- 1 ml.

12.89 g. ----- ?

$$\frac{12.89 \times 1}{1.84} = 7 \text{ ml.}$$

Quantity of commercial concentrated H₂SO₄ required to make 500 ml. of

0.5 N H₂SO₄ = 7ml.

Method of preparation :

1. Measure accurately 7 ml. of commercial concentrated H_2SO_4 .
2. Gradually add to about 375 ml. of water, mix and cool.
3. Dilute to 500 ml. volume with water.
4. Standardise and adjust normality if necessary.

Problem 6

Prepare 250 ml. of 1N H_2SO_4 (Concentration of commercial concentrated $\text{H}_2\text{SO}_4 = 36 \text{ N}$)

Solution :

Concentration of commercial concentrated $\text{H}_2\text{SO}_4 = 36 \text{ N}$

Concentration of dilute H_2SO_4 to be prepared = 1 N

$$\text{Dilution factor} = \frac{\text{Higher concentration}}{\text{lower concentration}} = \frac{36}{1} = 36$$

i.e. 1 ml. of commercial concentrated H_2SO_4 diluted to 36 ml. makes 1N H_2SO_4

Quantity of commercial concentrated H_2SO_4 required to make 250 ml. of 1N $\text{H}_2\text{SO}_4 =$

$$\begin{array}{r} 36 \text{ ml.} \quad \text{-----} \quad 1 \text{ ml.} \\ 250 \text{ ml.} \quad \text{-----} \quad ? \\ \frac{250 \times 1}{36} = 7 \text{ ml.} \end{array}$$

Quantity of commercial concentrated H_2SO_4 required to make 250 ml. of 1N $\text{H}_2\text{SO}_4 = 7 \text{ ml.}$

Method of Preparation :

1. Measure accurately 7 ml. of commercial concentrated H_2SO_4 .
2. Add gradually to about 190 ml. of water, mix and cool.
3. Dilute to 250 ml. with distilled water.
4. Standardise and adjust normality if necessary.

Relation between Molarity and Normality :

$$\text{Normality} = \text{Molarity} \times \frac{\text{Molecular weight}}{\text{Equivalent weight}}$$

Molal Solutions : Molal solution is defined as solution containing one mole of solute in one kilogram of solvent.

Molality : Molality is the number of moles of solute per one kilogram of solvent. It is denoted by m.

$$m = \frac{\text{number of moles of solute}}{\text{weight of solvent in Kg.}}$$

Ex: 1m HCl means 36.5 g HCl in 1 Kg. water.

Formality : It is the number of formula weight in gm. dissolved per litre of solution. When formula weight is equal to the molecular weight, formality is same as Molarity.

Mole Fraction : It is the ratio of number of moles of one of the components to the total number of moles of solute and solvent. It is denoted by 'x'. If 'n₁' is number of moles of solute, 'n₂' is number of moles of solvent, 'x₁' is mole fraction of solute and 'x₂' is mole fraction of solvent,

$$x_1 = \frac{n_1}{n_1 + n_2} \quad \text{and} \quad x_2 = \frac{n_2}{n_1 + n_2}$$

$$x_1 + x_2 = 1.$$

Conversion of mg% to meq/L :

$$\text{Concentration in meq/L} = \frac{\text{mg. per 100 ml.} \times 10 \times \text{valency}}{\text{molecular weight}}$$

SUMMARY

Solutions are monophasic mixtures of two or more substances in which solute is dissolved in solvent. Solutions are classified on the basis of states of matter of solute and solvent. Concentrations are expressed as percentage, molarity, normality, molality, mole fraction and formality. Percentage solutions are weight in volume (w/v) solutions, weight in weight (w/w) solutions, volume in weight (v/w) solutions and volume in volume (v/v) solutions.

Molarity is number of moles of substance present in one litre solution. Normality is number of gram equivalents present in one litre of solution. Molality is number of moles present in one Kg. solvent. Mole fraction is ratio of number of moles of one of the components of the solution to the total number of moles of solute and solvent. Formality is number of formula weight in gm dissolved in litre of solution.

Essay Questions

1. Define solutions. Classify and exemplify solutions.
2. What are different methods of expressing concentration? Classify solutions on that basis.
3. Mention different types of percentage solutions. Write about weight in volume percentage solutions and their preparation.
4. What are the general applications of different types of percentage solutions? Write about volume in volume percentage solutions and their preparation.
5. Write about molar solutions and their preparation.
6. Write about normal solutions and their preparation.

Short Answer Questions

1. Define solution.
2. Define solute, solvent.
3. Give examples of a) Solid in liquid solution b) Liquid in liquid solution.
4. What is percentage solution?

5. What is a weight in volume percentage solution? Give the general formula.
6. Define weight in weight percentage solutions. Write general formula.
7. Define volume in weight percentage solutions. Write the general formula.
8. What is a volume in volume percentage solution? Give the general formula.
9. Define molarity.
10. What is a molar solution?
11. Define mole.
12. What is meant by gram molecular weight?
13. Write molarities of commercially available a) Concentrated HCl b) Concentrated H_2SO_4 .
14. Mention specific gravities of commercially available a) Concentrated HCl b) Concentrated H_2SO_4 .
15. Mention the percentages by weight of actual content present in commercially available a) Concentrated HCl b) Concentrated H_2SO_4 .
16. Give the normalities of commercially available a) Concentrated HCl b) Concentrated H_2SO_4 .
17. Mention the relation between molarity and normality.
18. What is molality?
19. What is molal solution?
20. Define formality.
21. What is mole fraction?

PROBLEMS

1. Prepare 75 ml. of 1% w/v glucose stock standard solution with 0.25% w/v aqueous benzoic acid solution as solvent.
2. Prepare 60 ml. of 0.1% w/v glucose working standard from 1% w/v glucose stock standard solution.

3. Prepare 100 ml. of 70% v/v alcohol from absolute alcohol
4. Prepare 150 ml. of 80% v/v alcohol from absolute alcohol.
5. Prepare 60 ml. of 0.2M HCl.
6. Prepare 75 ml. of 0.5M HCl from commercial concentrated HCl.
(Specific gravity of commercial concentrated HCl = 1.16, % age by weight = 36% w/w)
7. How do you prepare 300 ml. of 0.2 M H_2SO_4 from commercially available concentrated H_2SO_4 ?
(Specific gravity of commercial concentrated H_2SO_4 = 1.84
% age by weight - 95% w/w)
8. Prepare 250 ml. of 0.2 M HCl by dilution from commercial concentrated HCl (molarity of commercial concentrated HCl = 12M)
9. Prepare 250 ml. of 0.1 N HCl.
10. Prepare 300 ml. of 0.5 N NaOH.
11. Prepare 500 ml. of N/10 HCl from commercial concentrated HCl.
(Specific gravity of commercial concentrated HCl = 1.16
% age by weight - 36% w/w)
12. Prepare 500 ml. of 2/3 NH_2SO_4 .
(Specific gravity of commercial concentrated H_2SO_4 = 1.84,
% age by weight = 95% w/w)
13. Prepare 250 ml. of 2/3 NH_2SO_4 from commercial concentrated H_2SO_4 by dilution (concentration of commercial concentrated H_2SO_4 = 36 N)

12 - CARBOHYDRATES AND LIPIDS

i. Carbohydrates :

Definition: Earlier definition of carbohydrates was they are hydrates of carbon. Hydrogen and oxygen being in the ratio as in water molecule, they were regarded as hydrates of carbon. The general formula for hydrate of carbon is $C_x(H_2O)_y$. Some compounds like glucose ($C_6H_{12}O_6$) [$C_6(H_2O)_6$] and sucrose $C_{11}H_{22}O_{11}$ [$C_{12}(H_2O)_{11}$] correspond to this general formula whereas carbohydrates like Rhamnose $C_6H_{12}O_5$ and Rhamnohexose $C_7H_{14}O_6$ do not correspond to this general formula. Some non-carbohydrates like Formaldehyde-HCHO (CH_2O) and acetic acid CH_3COOH ($C_2[H_2O]_2$) are corresponding to this formula. Now, carbohydrates are defined as polyhydroxy aldehydes or ketones or substances which yield these on hydrolysis.

Biological importance :

1. Cellulose is the most abundant cell wall and structural polysaccharide in plants.
2. They give protection to unicellular organisms. Gram positive and gram negative bacteria have one molecular feature in common. In both, rigid structural framework consists of parallel polysaccharide chains covalently cross linked by peptide chains. It is called as peptidoglycan or murein.
3. Glycoproteins are found in all forms of life.
4. Human blood group proteins contain oligosaccharide side chains which determine blood group specificity.
5. Polysaccharide chitin is the major organic element in the exoskeleton of insects and crustacea.
6. Hyaluronic acid is involved in the lubrication of bone joints of animals. It resists penetration of bacteria and substances.
7. Heparin acts as anticoagulant and is found in liver, spleen, lungs and thymus.
8. Ribose is involved in the synthesis of DNA and RNA. Which determine heredity.
9. During digestion, carbohydrates are broken down to monosaccharides-Glucose,

fructose etc., which are used in production of energy. Storage form of glucose in the body is glycogen.

Classification of Carbohydrates :

Carbohydrates may be classified into two major groups

1. Sugars (Sweet substances)
2. Non-Sugars (Which are not sweet)

1. Sugars : They are classified into a) Monosaccharides b) Oligosaccharides

a) Monosaccharides : They are the simplest carbohydrates which cannot be further hydrolysed into simple carbohydrates.

They can again be classified on the basis of functional group and number of carbon atoms.

Classification based on functional group : On the basis of functional group contained, monosaccharides can be classified into :

1) Aldoses containing Aldehyde functional group. 2) Ketoses containing ketone functional group.

Classification based on number of carbon atoms : On the basis of number of carbon atoms contained, monosaccharides can be classified into :

1. Trioses containing three carbon atoms.
2. Tetroses containing four carbon atoms.
3. Pentoses containing five carbon atoms.
4. Hexoses containing six carbon atoms.
5. Heptoses containing seven carbon atoms.
6. Octoses containing eight carbon atoms.

Each exists in two series.

Trioses :	1) Aldo trioses	Ex: Glyceraldehyde
	2) Keto trioses	Ex: Dihydroxy acetone

Tetroses :	1) Aldo tetroses	Ex: D-Erythrose
	2) Keto tetroses	Ex: D-Erythrulose
Pentoses :	1) Aldo pentoses	Ex: D-Ribose
	2) Keto pentoses	Ex: D-Ribulose
Hexoses :	1) Aldo hexoses	Ex: D-Glucose
	2) Keto hexoses	Ex: D-Fructose

b) Oligosaccharides :

Oligosaccharides are the carbohydrates which on hydrolysis yield two or more monosaccharides. They are further classified into 1) Disaccharides 2) Trisaccharides 3) Tetrasaccharides.

1) Disaccharides : Disaccharides are the Oligosaccharides which on hydrolysis yield two monosaccharides.

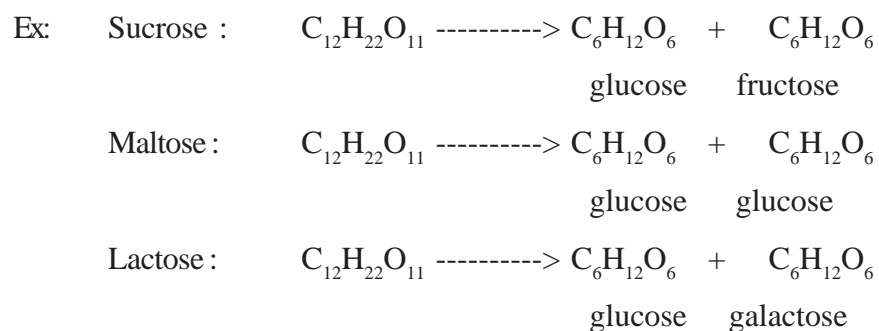

2. Trisaccharides : Trisaccharides are oligosaccharides which yield 3 monosaccharides on hydrolysis.



3. Tetrasaccharides : Tetrasaccharides are oligosaccharides which yield 4 monosaccharides on hydrolysis.



2. Non-Sugars or Polysaccharides : They are usually tasteless amorphous solids insoluble in water and form colloidal suspensions in water which on hydrolysis yield many monosaccharide molecules.

Polysaccharides can be further classified into i) Homopolysaccharides ii) Heteropolysaccharides.

i) Homopolysaccharides : Homopolysaccharides are polysaccharides made of single type of monosaccharide units.

Ex: Starch , Cellulose , Glycogen , Insulin.

ii) Heteropolysaccharides : Heteropolysaccharides are polysaccharides made of different types of monosaccharides.

Ex: Heparin, Hyaluronic acid, Chondroitin Sulphate.

Structures of some important carbohydrates :

D) Aldoses :

a) Aldo Triose :

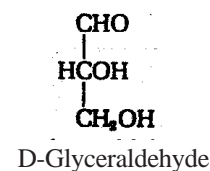

b) Aldo Tetroses :

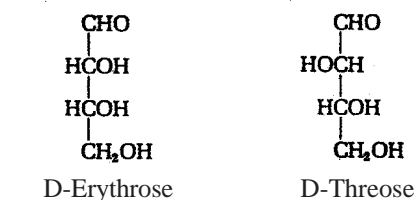

c) Aldo Pentoses :

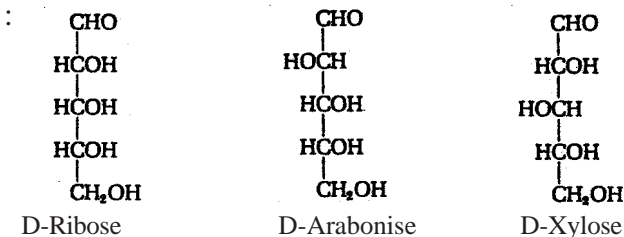

d) Aldo Hexoses :

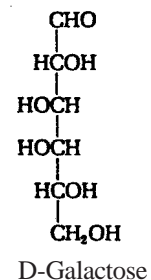
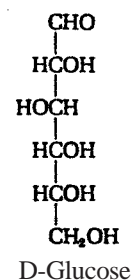

II) Ketoses :

a) Keto Triose :

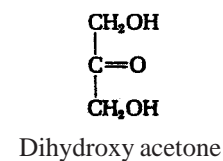

b) Keto Tetrose :

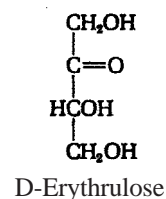

c) Keto Pentoses :

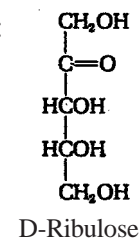

d) Keto Hexoses :

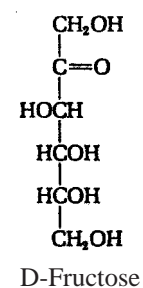

Qualitative tests for Carbohydrates : Reducing sugars give positive results for Tollen's test, Benedict's test and Fehling's test. All monosaccharides are reducing sugars. Ex.: Glucose and Fructose.

Sucrose of disaccharides is non-reducing. Maltose and Lactose are reducing.

Tollen's Test : Reducing sugars on reaction with Ag^+ (Ammonia complex) gives silver mirror.

Benedict's Test : Reducing sugars on reaction with Cu^{++} (citrate complex) give yellow-red precipitate of Cu_2O .

Fehling's Test : Reducing sugars on reaction with Cu^{++} (Tartarate complex) give yellow-red precipitate of Cu_2O .

Selvinoff's Test for Fructose : Fructose solution on addition of Selvinoff's reagent and heating on boiling water bath for 5 minutes produces deep reddish colour.

O - Toluidine Test for Galactose : Addition of O-Toluidine reagent to galactose solution and heating over boiling water bath for 10 minutes produces green colour.

Rubner's Test for Lactose : Add 2.5 gms. of Lead acetate solution to solution of lactose and filter. Boil filtrate in another tube, add 1.5 ml of NH_4OH and boil again for few seconds. Red colour with red precipitate forms on cooling.

Tauber's Test for Pentose Sugars : Addition of Tauber's reagent to Pentose sugar solution, boiling for 30 seconds and cooling develops pink to red colour.

Osazone Test for Carbohydrates : Solution of carbohydrate taken in a dry test tube and acidified with a few drops of glacial acetic acid on addition of osazone mixture should be placed in boiling water bath for 40-60 minutes. This tube should be cooled over night and its deposit to be observed under microscope. Glucose forms yellow sheaves of slender needle like glucosazone crystals. Lactose forms close tufts of short fine crystals of lactosazone. Maltose forms clusters of broad bladed crystals of maltosazone.

ii. Lipids : Lipids are water insoluble components of cells, soluble in nonpolar solvents like acetone, ether, chloroform or benzene.

Classification : On the basis of nature of products obtained on hydrolysis, lipids are mainly divided into two types.

1. Simple lipids

2. Conjugated lipids

3. Derived lipids form third category though they do not contain ester linkage.

1. Simple lipids : Simple lipids are esters of fatty acids with glycerol or fatty alcohols. Simple lipids are two types. a) Fats and Oils b) Waxes.

a) Fats and Oils: Fats and Oils are esters of fatty acids with glycerol. Difference between fats and oils is, fats are solids at ordinary temperature where as oils are liquids at ordinary temperature. Ex: Coconut oil, arachis oil, olive oil.

Waxes : Waxes are esters of fatty acids with higher molecular weight monohydric alcohols or with sterols.

Ex: Bees wax, Lanolin, spermaceti.

Conjugated Lipids : Conjugated lipids are lipids conjugated with nonfatty prosthetic groups.

Phospho lipids: Phospholipids are lipids conjugated with phosphoric acid and nitrogenous component in the molecule.

Ex: Lecithin, cepahlin, sphingomyelins etc.

Glyco lipids : Glyco lipids also called as cerebrosides are lipids containing sugar in glycosidic linkage with glycerol.

Ex: Phrenosin, cerebron, nervon, oxynervon. Cerebrosides are present in brain.

Sulpho lipids : They are lipids conjugated with sulfuric acid.

Lipoproteins : Lipids in the state of conjugation with proteins are called as lipoproteins.

There are four types of lipo proteins.

1. Chylomicrons
2. Very low density lipo proteins
3. Low density lipo proteins
4. High density lipo proteins.

Derived Lipids : Derived lipids are substances derived by hydrolysis of simple

and compound lipids. Saturated and unsaturated fatty acids, sterols, Alcohols, Glycerols etc. come under derived lipids.

Saturated fatty acids:

Ex:	Acid	Formula
	Acetic acid	CH_3COOH
	Propionic acid	$\text{C}_2\text{H}_5\text{COOH}$
	Butyric acid	$\text{C}_3\text{H}_7\text{COOH}$
	Caproic acid	$\text{C}_5\text{H}_{11}\text{COOH}$
	Caprylic acid	$\text{C}_7\text{H}_{15}\text{COOH}$
	Decenolic acid	$\text{C}_9\text{H}_{19}\text{COOH}$
	Lauric acid	$\text{C}_{11}\text{H}_{23}\text{COOH}$
	Myristic acid	$\text{C}_{13}\text{H}_{27}\text{COOH}$
	Palmitic acid	$\text{C}_{15}\text{H}_{31}\text{COOH}$
	Stearic acid	$\text{C}_{17}\text{H}_{35}\text{COOH}$
	Arachidic acid	$\text{C}_{19}\text{H}_{39}\text{COOH}$
	Behenic acid	$\text{C}_{21}\text{H}_{43}\text{COOH}$
	Lignoceric acid	$\text{C}_{23}\text{H}_{47}\text{COOH}$

Unsaturated fatty acids :

Fatty acids containing one or more double bonds are unsaturated fatty acids. They can be subdivided in accordance with the number of double bonds.

1. Oleic Series : Oleic series contain one double bond. Ex: Oleic acid
2. Linoleic Series : Linoleic series contain two double bonds. Ex: Linoleic acid
3. Linolenic Series : Linolenic series contain three double bonds. Ex: Linolenic acid.
4. Arachidonic acid contains 4 double bonds.

Sterols :

They are derived lipids having cyclic structure obtained from nature. Steroids have cyclopentano perhydro phenanthrene ring.

Sterols can be classified into following categories.

1. Sterols - Cholesterol
2. Bile acids - Glycocholic and Taurocholic acids.
3. Sex hormones - Testosterone, oestradiol
4. Adreno cortical hormones - Corticosterone, Cortisone
5. Vitamins D, E, K etc.
6. Cardiac glycosides - Strophanthin
7. Saponins - Digitonin

Essential fatty acids :

Mammals can synthesize saturated and mono unsaturated fatty acids. They are unable to synthesize linoleic acid and gamma linoleic acid. They must be supplied through plant sources. These fatty acids which can not be synthesized in the body and have to be supplied through food are called as essential fatty acids.

Linoleic acid is a precursor for the biosynthesis of arachidonic acid, which is not found in plants. Essential fatty acids are precursors in the biosynthesis of prostaglandins.

Biological Importance of lipids:

1. Sphingo lipids containing sphingosine or a related base are important components in both plant and animal cells. They are present in large amounts in brain and nervous tissue.
2. Sphingomyelins are abundant in the tissues of higher animals.
3. Neutral glycosphingo lipids are important cell-surface components of animal tissues. Simplest of these are cerebroside.
4. Some of the neutral sphingo lipids are found on the surface of erythrocytes and give them blood group specificity. They are partly responsible for the necessity of matching donor's and recipient's blood before transfusion.
5. Most complex group of glycosphingo lipids are gangliosides. Gangliosides are most abundant in the gray matter of the brain. Gangliosides function in the transmission of nerve impulses across the synapses.
6. Some of the cell surface glycosphingo lipids are also responsible for organ

and tissue specificity. These complex lipids are also involved in tissue immunity and cell-cell recognition.

7. Cancer cells have characteristic glycosphingo lipids different from those in the normal cells.
8. Fat soluble vitamins A, D, E, K are lipids.
9. Acetic acid is used for synthesis of cholesterol. Cholesterol is the precursor of many other steroids in animal tissues including bile acids, androgens - male sex hormones, oestrogen-female sex hormone. Progestational hormone - progesterone and adreno cortical hormones.
10. Prostaglandins are a family of fatty acid derivatives. They have physiological activities of regulatory nature. In very small amounts, this material lowers blood pressure and stimulates contraction of smooth muscles.
11. Plasma lipoproteins carry various water insoluble lipids among various organs of body via blood.
12. Most membranes contain about 40% of lipid. Membranes serve not only as barriers but also for binding certain enzymes and also acts as transport systems.

Acid Value or Acid Number : It indicates the amount of free fatty acid present in an oil. i.e. number of mg. of KOH required to neutralise free fatty acids in 1 gram of fat or oil.

Iodine Value or Iodine Number : It is measure of degree of unsaturation of fat or oil and is defined as number of grams of iodine absorbed by 100 grams of fat or oil.

Saponification Value or Number : It is the number of mg. of KOH required to saponify 1 gm. of oil or fat.

SUMMARY

Carbohydrates are polyhydroxy aldehydes or ketones or substances which yield these on hydrolysis carbohydrates have significant role in living cells. Carbohydrates are classified into a) Sugars b) Non sugars. Sugars are classified into mono saccharides, disaccharides, trisaccharides and tetrasaccharides. Monosaccharides are further classified into trioses, tetroses, pentoses, hexoses, heptoses and octoses. Non sugars are polysaccharides. They are further classified into homo polysaccharides and heteropolysaccharides.

Lipids are water insoluble components of cells. They are soluble in non polar solvents like acetone, ether, chloroform or benzene etc. They are classified into simple lipids, conjugated lipids and derived lipids. Essential fatty acids are those which can not be synthesized in the body and hence must be supplied through plant sources. Dietary lipids are hydrolysed to fatty acids and glycerol. Fatty acids are required for energy production. Glycerol enters into glycolysis and free fatty acid undergoes Beta-oxidation in mitochondria.

Qualitative tests for Carbohydrates are Tollen's test, Benedict's test, Fehling's test, Selvinoff's Test, O-Toluidine Test, Rubner's Test, Tauber's Test and Oszone Test etc.

Essay Questions

1. Write the biological importance of carbohydrates.
2. Classify carbohydrates.
3. What are lipids? Classify them.
4. What are saturated and unsaturated fatty acids? Write with examples.
5. Define sterols and classify them. Give the structure of cholesterol.
6. Write the biological importance of lipids.

Short Answer Questions

1. Define carbohydrates.
2. What is the function of cellulose in plant and animal tissues?
3. What is peptidoglycan?
4. Mention the uses of a) Chitin b) Hyaluronic acid.
5. What are the sources of heparin?
6. Write the uses of a) Heparin b) Ribose.
7. What are monosaccharides?
8. Mention types of Hexoses on the basis of functional group.
9. Write the number of carbon atoms in a) Trioses b) Hexoses.
10. Give examples each for a) Aldotriose b) Keto triose.
11. Exemplify tetroses
12. Give one example each for aldopentoses and ketopentoses.

13. Give one example each for a) Aldohehexoses b) Ketohehexoses
14. What are oligo sacharides?
15. Write the products of hydrolysis of sucrose and maltose.
16. What are homopolysacharides? Give examples.
17. Define heteropolysacharides and exemplify.
18. What is a lipid?
19. Define simple lipids.
20. Differentiate between fats and oils.
21. Differentiate between fats / oils and waxes.
22. Give examples of phospho lipids.
23. Exemplify glycolipids.
24. What are sulfolipids?
25. Define lipo proteins.
26. Mention different types of lipo proteins.
27. What are derived lipids?
28. What are saturated fatty acids?
29. Define unsaturated fatty acids.
30. What is an essential fatty acid?
31. Name the lipids present in brain and nervous tissue.
32. What are the lipids present in cell surface of animal tissues?
33. Which lipids give blood group specificity?
34. What is the function of gangliosides?
35. Name fat soluble vitamins.
36. Mention steriods which are synthesized from cholesterol.
37. What are prostaglandins?
38. What is the function of plasma lipo proteins?
39. What is acid value?
40. Define iodine value.
41. Write about seponification value.

13 - AMINO ACIDS AND PROTEINS

Amino acids: Amino acids are the building blocks of proteins in which an amino group is attached to carbon atom next to carboxyl group. Hence they can also be called as α -amino carboxylic acids (α -amino acids) and are represented by the general formula:

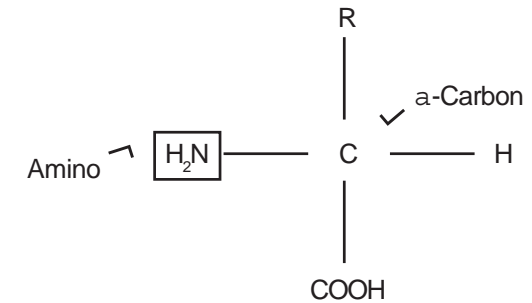

Classification:

On the basis of capability / noncapability of biosynthesis of amino acids in the body, they can be classified into 1. Essential amino acids 2. Non-essential amino acids

1. Essential amino acids :

These cannot be synthesized in the body and hence must be supplied through diet.

They are leucine, isoleucine, proline, hydroxyproline, threonine, methionine, tryptophan, arginine, lysine.

2. Non essential amino acids :

Amino acids which can be synthesized in the body are called as non-essential amino acids. They are glycine, alanine, serine, aspartic acid, glutamic acid, valine, phenyl alanine, tyrosine, serine, cysteine cystine etc.

They can also be classified as

1. Mono amino mono carboxylic acids
(Neutral amino acids)
2. Mono amino dicarboxylic acids
(Acidic amino acids)

3. Diamino monocarboxylic acids

(Basic amino acids)

1. Mono amino mono carboxylic acids (Neutral amino acids) :

They are amino acids containing one amino group and one carboxylic group as in glycine, alanine.

Glycine - $\text{NH}_2\text{CH}_2\text{COOH}$ (Amino acetic acid)

Alanine - $\text{CH}_3\text{CH} - \text{COOH}$ (α -amino propionic acid)



2. Mono amino dicarboxylic acids:

They are amino acids containing one amino group and two carboxyl groups as in aspartic and Glutamic acid.

Aspartic acid - $\text{HOOC} - \text{CH}_2 - \text{CH} - \text{COOH}$ (α -amino succinic acid)



Glutamic acid - $\text{HOOC} - \text{CH}_2 - \text{CH} - \text{COOH}$ (α -amino succinic acid)



Diamino mono carboxylic acids :

They are amino acids containing two amino groups and one carboxyl group as in lysine.

Lysine - $\text{NH}_2 - (\text{CH}_2)_4 - \text{CH} - \text{COOH}$ (α - ϵ -diamino caproic acid)



They can also be classified on the basis of type of side chain into

1. Amino acids containing aliphatic side chains.

Ex. $\text{CH}_3\text{CH} - \text{COOH}$ (α -amino propionic acid)



2. Amino acids with side chains containing hydroxyl groups

Ex: Serine $\text{CH}_2 - \text{CH} - \text{COOH}$

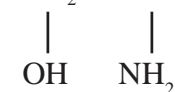

3. Amino acids with side chains containing sulfur atom

Ex: Cysteine $\text{CH}_2 - \text{CH} - \text{COOH}$



4. Amino acids containing aromatic rings

Ex: Phenyl alanine $\text{C}_6\text{H}_5 - \text{CH}_2 - \text{CH} - \text{COOH}$



5. Imino acids

Ex: Proline

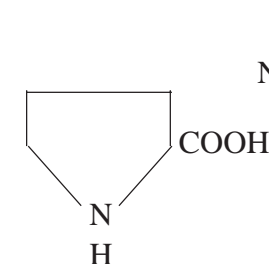

Most Common amino acids

Name of amino acid	Symbol	Structure
Alanine	A / Ala	$\begin{array}{c} \text{H} \\ \\ \text{CH}_3 - \text{C} - \text{COOH} \\ \\ \text{NH}_2 \end{array}$

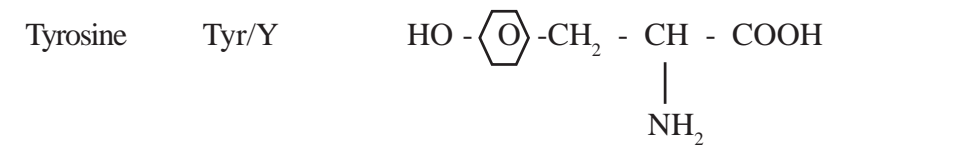
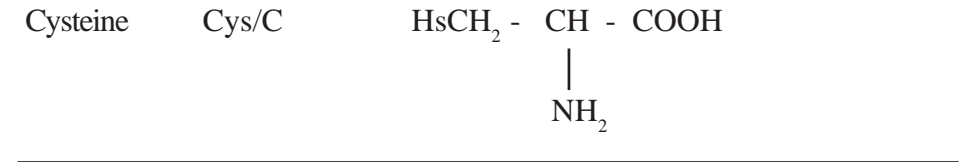
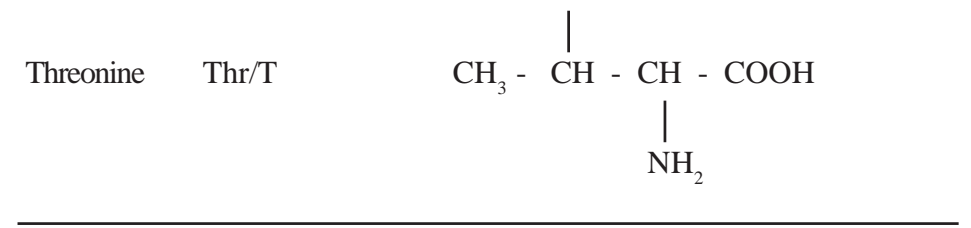
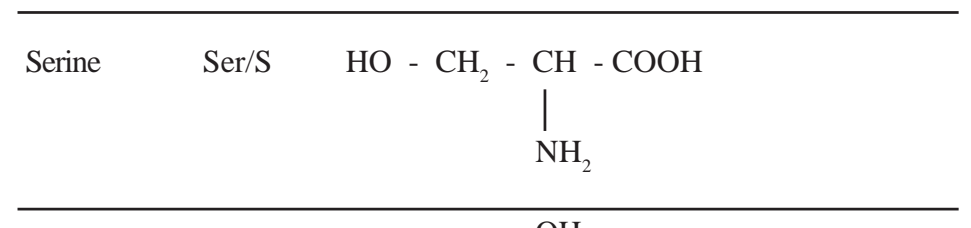
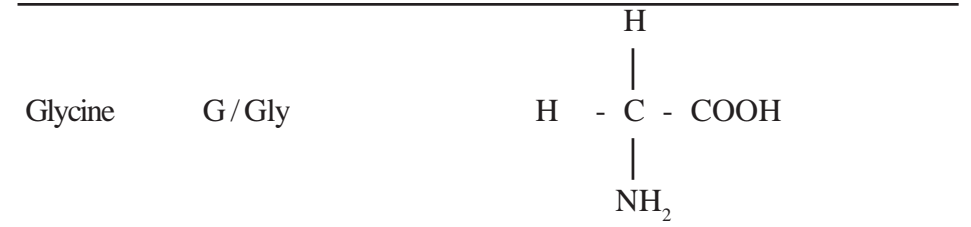
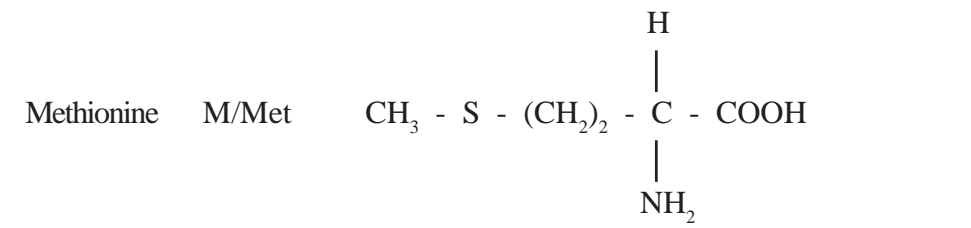
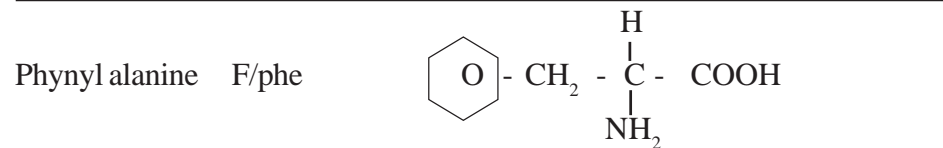
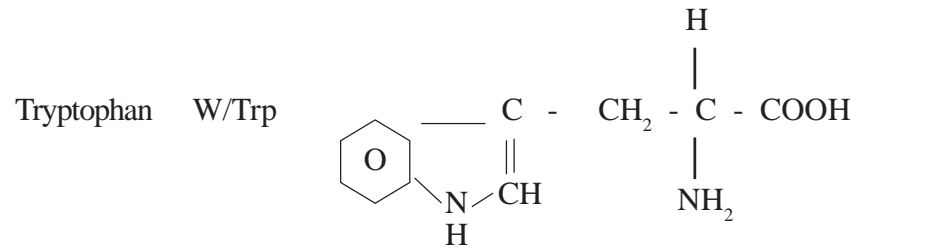
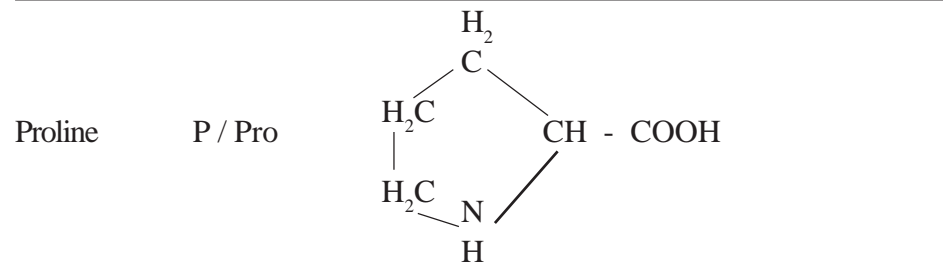
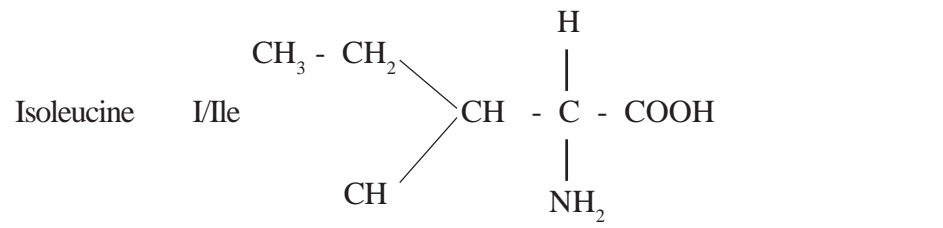
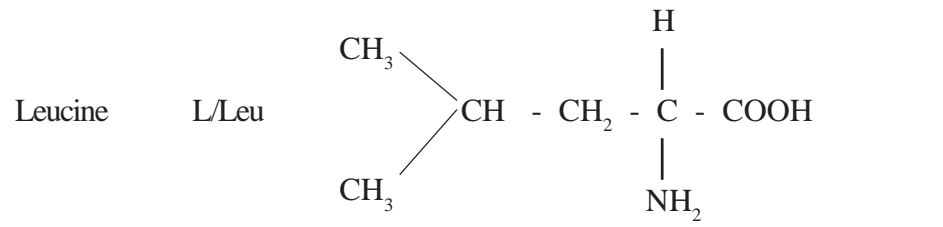
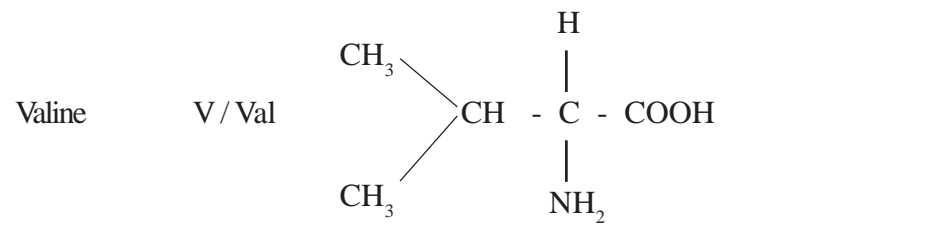

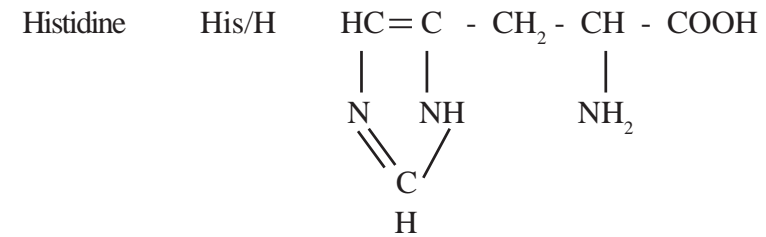
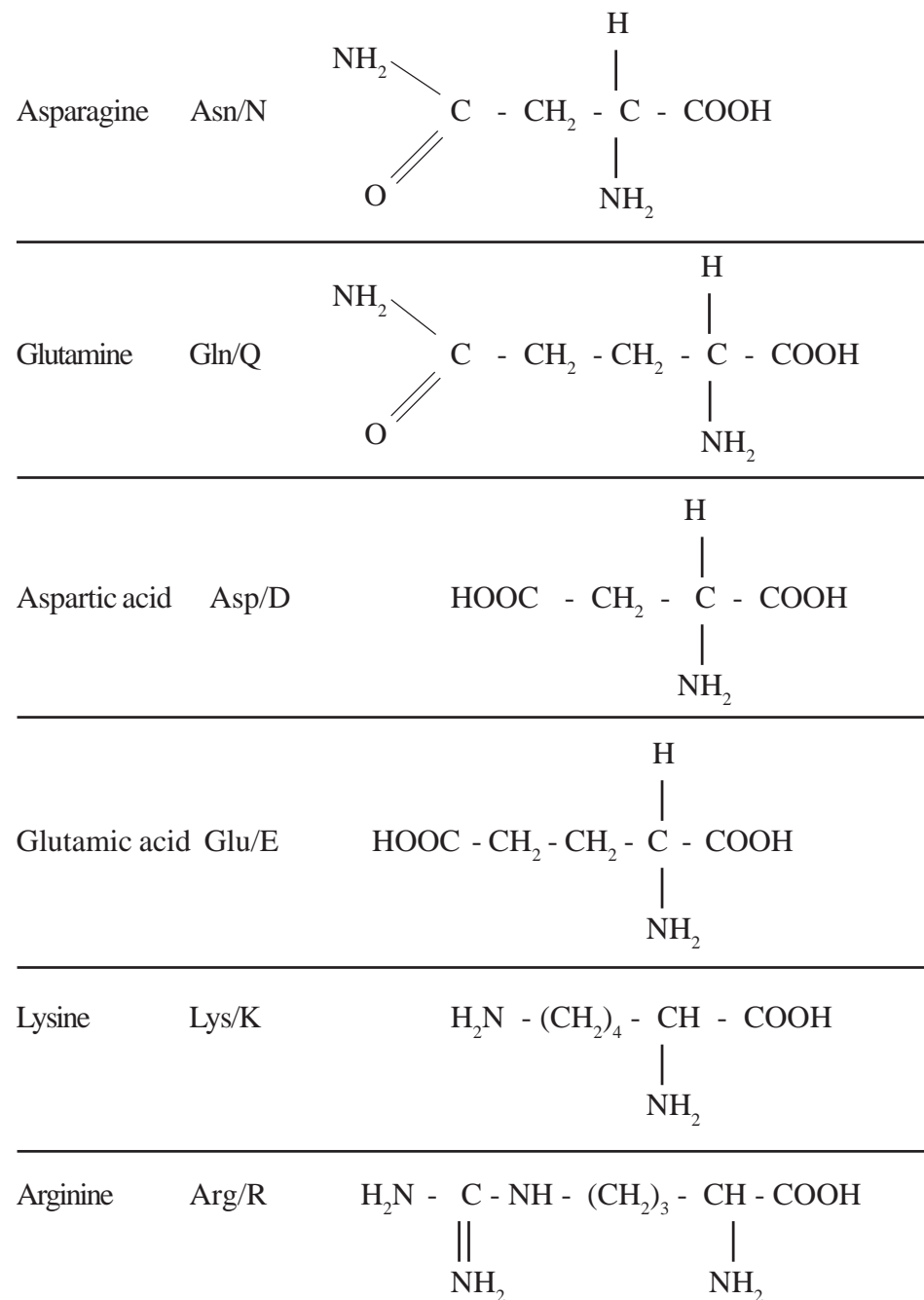

Qualitative Test for Amino acids : Amino acids react with Ninhydrin to give violet colour. This test is used for qualitative identification of amino acids. It is also helpful in quantitative determination of amino acids.

PROTEINS

Proteins are the most abundant biomolecules in cells which are chemically polypeptides having a variety of cells united by peptide bonds (amide bonds) in simple or branched chains. They are one of the chief constituents of living matter.

Classification of Proteins :

1. Fibrous proteins
2. Globular proteins
3. Intermediates

Fibrous proteins :

Fibrous proteins are Poly peptide chains arranged in parallel along a single axis to yield fibres or sheets. They are soluble in strong acids and alkalies, but in soluble in common solvents.

Ex: Collagen present in tendons and bones
 α -keratin present in hairs, nails, skin, horn
 elastin present in elastic connective tissue.

Globular proteins :

Globular proteins consist of polypeptide chains folded into compact spherical shapes. Globular proteins are soluble in water, dilute acids, dilute alkalies etc. Almost all enzymes, antibodies and many hormones are globular proteins. Proteins having transport function are also globular proteins Ex: Haemoglobin, Albumin.

Intermediates :

Proteins resembling fibrous proteins in conformation and globular proteins in solubility properties fall into this category.

Ex: Fibrinogen (Plasma protein)
Myosin (Muscle protein)

Most common method of classification is as follows :

1. Simple Proteins
2. Conjugated Proteins
3. Derived Proteins

Simple Proteins : Simple Proteins are proteins which on hydrolysis yield amino acids only.

Ex: Albumin of Egg white, Globulin of Egg yolk, Keratin of hair, nails, skin, horn; Collagen of Bones and tendons, Elastin of elastic connective tissue.

Conjugated Proteins : Conjugated Proteins are simple proteins combined with non prosthetic group. They are

1. Nucleo Proteins: Proteins containing nucleic acid as prosthetic group are nucleo proteins.
2. Glyco proteins : Proteins containing carbohydrate as prosthetic group are glycoproteins.
3. Phosphoproteins : proteins containing phosphoric acid as prosthetic group are phosphoproteins.
4. Lipo proteins : Proteins containing lipids as prosthetic group are lipoproteins.
5. Chromoproteins: Proteins containing a metal like iron, magnesium, copper, cobalt etc. as prosthetic group are chromo proteins. Prosthetic groups give colour rendering them pigments.

Ex: Chlorophyll, haemoglobin.

3. Derived Proteins :

They are the products resulting from hydrolysis by the action of acids, alkalies or enzymes etc.

Biological importance of amino acids

1. Glycine and glutamic acid are involved in the transmission of impulses in the nervous system.

2. They are the building blocks of proteins.
3. They are essential in the replacement of daily wear and tear.
4. Many amino acid derivatives are hormones - Adrenaline, Noradrenaline, thyroxine etc.
5. Metabolic products of certain amino acids provide source of energy.
6. Arginine forms intermediate product in urea synthesis.

Biological importance of proteins :

Proteins have quite diverse important functions to conduct in living cells.

1. They serve as structural elements. Collagen is the structural protein in bones and tendons. Keratin is present in hair, skin, nails. Elastin is present in elastic connective tissue.
2. Most interesting importance of proteins acting as hormones are regulation of physiological activities such as growth by growth hormone, regulation of metabolism of carbohydrates by insulin etc.
3. Some proteins have a defensive function. Thrombin and fibrin are responsible for blood clotting and prevent loss of blood. Antibodies and immunoglobulins constitute the body's defence mechanism.
4. Transport function is conducted by some proteins.
Hb carries - O₂, CO₂
Myoglobin transports O₂ in muscles.
Lipo proteins transport lipids
5. All enzymes are proteins. They catalyse different biochemical reactions in body. SGOT & SGPT are involved in transamination reaction. LDH dehydrogenates lactate.
6. Actin and Myosin are contractile proteins in muscle fibres.
7. Toxins like Ricin of castor seed, gossypin of cotton seed, diphtheria toxin of coryne bacterium diphtheriae, Clostridium botulinum toxin of clostridium botulinum are toxic substances in minute quantities and they represent one form of proteins.
8. Ovalbumin of egg white, casein of milk, Ferritin storing iron etc. are storage proteins performing the function of storage.
9. Spiders and silk worms produce thick solution of protein fibroin which

quickly solidifies into insoluble thread.

10) Blood of some fishes living in sub zero temperatures contain anti freezing proteins.

Qualitative Tests for Proteins :

- 1) *Coagulation test* : Proteins on heating, on exposure to U.V. radiation, on reaction with acids undergo coagulation. i.e. precipitation. When precipitation is irreversible, it is called de-naturation.
- 2) *Colour reactions* : Proteins give colour reactions with many reagents. This property can be used for their qualitative identification.
 - a) *Biuret Test* : Proteins on treatment with alkaline copper sulphate solution gives red or violet colour. This test is given by all proteins containing two or more peptide linkages.
 - b) *Millon's reaction* : Addition of Millon's reagent to a protein solution gives white precipitate. This test is given by proteins yielding tyrosine on hydrolysis.
 - c) *Xanthoproteic test* : Protein on warming with concentrated nitric acid gives yellow colour. This test is given by proteins containing amino acids with benzene ring. Ex: Tyrosine, Tryptophan. This is due to nitration of aromatic rings.
 - d) *Ninhydrin test* : Proteins on boiling with dilute aqueous solution of ninhydrin produce violet colour. This test is given by alpha amino acids, proteins and dipeptides.
 - e) *Hopkins-Cole test*: Concentrated sulphuric acid when added down the side of a test tube containing protein and glyoxylic acid, violet ring appears between two layers. This test is given by proteins having tryptophan in its structure.

SUMMARY

Amino acids are building blocks of proteins in which an amino group is attached to carbon atom next to carboxyl group and hence also called as - Alpha amino carboxylic acids. Essential amino acids are those which are not synthesized in the body and hence must be supplied through diet. Non essential amino acids are those which can be synthesized in the body. Mono amino carboxylic acids contain one amino group and one carboxyl group. Mono amino dicarboxylic acids contain one amino group and two carboxyl groups. Diamino

monocarboxylic acids contain two amino groups and one carboxyl group. Some amino acids contain hydroxyl group in the side chain. Some amino acids contain sulfur atom in the side chain. Some amino acids contain aromatic ring. Some are imino acids. Amino acids give positive result to Ninhydrin test.

Proteins are chemically polypeptides having variety of amino acids united by peptide bonds. They are classified into fibrous proteins, globular proteins and intermediates on the basis of conformation and solubility. They can also be classified into simple proteins, conjugated proteins and derived proteins. Proteins give positive result to coagulation test. Proteins also give colour reactions.

Amino acids and proteins are biologically significant. They are principally responsible for replacing wear and tear of body.

Essay Questions

1. Define Amino acids. Give different classifications of amino acids.
2. Define and classify proteins.
3. Write the biological importance of amino acids and proteins.
4. Write qualitative tests for amino acids and proteins.

Short Answer Questions

1. What are essential amino acids?
2. Give the structures of Alanine and Phenyl alanine.
3. What is a fibrous protein?
4. Define simple proteins.
5. What are glyco proteins?
6. Name the amino acids responsible for transmission of impulses in the nervous system.
7. What are the proteins present in a) Hair, skin and nails b) Elastic connective tissue
8. Name the proteins of muscle fibres.
9. Write Biuret's test.
10. Explain Ninhydrin test.

14. DIAGNOSTIC TESTS

Blood Sugar :

Determination of blood sugar is significant in Diabetes miletus. Carbohydrates are converted to monosacharides (Glucose etc.) in the process of digestion. Glucose undergoes oxidation in tissues and produces energy required for routine day to day activities. Insulin is a hormone produced by Beta cells of Islets of langerhans of Pancreas. It increases utilisation of glucose by tissues. When there is absent or deficient secretion of insulin by the Beta cells of Islets of langerhans, glucose cannot be utilised by the cells properly resulting in its increased level in the blood. Normal value of fasting blood glucose is 80-120 mg %. When the fasting blood glucose level is more than 120 mg % the condition is called as Hyperglycaemia, which is the characteristic condition of diabetes miletus. Until the blood sugar level crosses 180 mg % glucose is not excreted in urine. This value is called as renal threshold value for glucose. The condition of appearance of glucose in urine is called as glycosuria.

Determination of Blood Glucose:

There are different methods for determination of blood glucose.

1. Folin and Wu's methods.
2. O-Toluidine method.
3. Glucose oxidase peroxidase method (Enzymatic method).

Determination of blood glucose by Folin & Wu method:

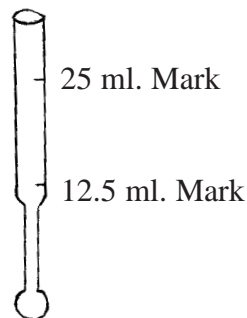

Principle : When protein free blood filtrate is heated with an alkaline copper solution, a precipitate of cuprous oxide is produced by the reducing action of glucose. This in turn is dissolved by phosphomolybdic solution and reduces it to a blue colored compound. Colour intensity of blue colour formed is compared with the colours intensity developed in a similarly treated standard solution of glucose using colorimeter.

Tungstic acid produced by reaction between sodium tungstate and sulphuric acid precipitates proteins and useful in preparation of protein free blood filtrate. Removal of protein helps in removing the interference of protein with glucose in the colorimetric estimation. Sodium carbonate present in the copper tartrate solution provides alkaline medium for reduction of copper to take place.

Requirements :

1. 10 ml. test tube
2. Folin & Wu tubes
3. Water bath
4. Beakers
5. Cuvettes
6. Centrifuge
7. Colorimeter

Reagents :

1. 10% sodium tungstate solution.

Composition : Sodium tungstate - 10g. , Distilled water up to 100 ml.

Method of Preparation : 10g. of sodium tungstate is accurately weighed, dissolved in approximately 75 ml. of water and diluted to 100 ml. with distilled water.

2. 2/3 N sulphuric acid

Method of preparation : Take 2 ml. of concentrated sulphuric acid, and dilute to 100 ml. with distilled water. Standardize the prepared solution

against a standard solution of alkali and adjust the normality if necessary.

3. Alkaline copper tartrate solution.

Requirements :

Anhydrous sodium carbonate - 20g.

Tartaric acid - 3.75 g.

Copper sulphate - 2.25 g.

Distilled water upto 500 ml.

Method of preparation :

1. Dissolve 20g. of anhydrous sodium carbonate in 200 ml. of distilled water.
2. Dissolve 3.75g. of tartaric acid in the solution prepared in step-1.
3. Dissolve 2.25g copper sulphate in the solution prepared in step-2.
4. Dilute the solution prepared in step 3. to 500 ml. with distilled water.

4. Phosphomolybdic reagent :

Requirements :

Molybdic acid - 17.5 g.

Sodium tungstate 2.5 g.

10% sodium hydroxide solution 100 ml.

Phosphoric acid - 62.5 ml.

Distilled water upto 250 ml.

Method of preparation :

1. Dissolve 17.5g of molybdic acid and 2.5g of sodium tungstate in 100 ml. of 10% sodium hydroxide solution.
2. Add 100 ml. distilled water and boil for 30 to 40 minutes. This will expel all the ammonia present in molybdic acid.
3. Cool and transfer to 250 ml. flask with washings.
4. Add 62.5 ml. of phosphoric acid.

5. Dilute to 250 ml with distilled water.

5. Glucose stock standard solution (1% w/v)

Composition : Glucose analar - 1g.

0.25% w/v Benzoic acid aqueous solution up to 100 ml.

Method of preparation :

Dissolve 1g. of glucose analar in about 75 ml. of 0.25% aqueous benzoic acid solution and dilute to 100 ml. with 0.25% aqueous solution of benzoic acid solution.

6. Glucose Working Standard (0.1% w/v) :

Composition : Glucose stock standard - 1 ml.

Distilled water upto 10 ml.

Method of preparation :

Dilute 1 ml. of glucose stock standard solution to 10 ml. with distilled water. This will give glucose solution of 0.1% w/v (100 mg / 100 ml.) concentration.

Wave length : 440 milli microns. (Dark blue filters)

Specimen : Blood

Preparation of protein free blood filtrate :

1. In a test tube, take 3.5 ml. of distilled water, 0.1 ml. of blood, 0.2 ml. of 10% sodium tungstate solution and mix.
2. Add 0.2 ml. of 2/3N sulphuric acid and mix.
3. Filter or centrifuge after 5 minutes.
4. Collect the filtrate into another test tube.

Procedure :

1. Take 3 folin and Wu sugar tubes. Label them as test (T), standard (S) and blank (B).
2. Proceed as follows :

Reagent	T	S	B
1. Protein free Blood filtrate	2 ml.	-	-
2. Working Standard	-	0.1 ml.	-
3. Distilled water	-	-	2 ml.
4. Alkaline copper Reagent	2 ml.	2 ml.	2 ml.
Mix well, remove and cool in a beaker of cold water for 2-3 minutes.			
5. Phosphomolybdic reagent	2 ml.	2 ml.	2 ml.
Stand for few minutes until cuprous oxide has completely dissolved.			
6. Distilled water	upto 12.5 ml. in F.W.tube	upto 12.5 ml. in F.W. tube	upto 12.5 ml. in F.W. tube

3. Set the colorimeter to 100% transmission at 440 milli microns wave length using blank.

4. Determine optical densities of T and S.

5. Determine the concentration with the formula

$$\text{concentration of blood glucose in mg\%} = \frac{\text{O.D. of test}}{\text{O.D. of standard}} \times \text{X concentration of standard (100 mg\%)}$$

Normal values : Fasting blood glucose values are between 80-120 mg%.

Determination of Blood glucose by O-Toluidine method :

Principle : Glucose reacts with orthotoluidine in hot acidic medium to form a green coloured complex. Acidic medium favours the reaction between O-Toluidine and glucose. Acidic medium is provided by glacial acetic acid present in the O-Toluidine reagent. Intensity of the colour developed is proportional to the concentration of glucose in plasma / serum. Concentration of glucose in plasma / serum can be calculated by comparing with the

intensity of colour developed in similarly treated standard.

Requirements :

1. Dispenser
2. Test tubes
3. Pipette
4. Water bath
5. Centrifuge
6. Colorimeter

Reagents :

1. O-Toluidine reagent :

Composition:

O-Toluidine - 60 ml.

Thiourea - 1.5 gms.

Glacial acetic acid up to 1 litre.

Method of Preparation :

1. Take 60 ml. of O-Toluidine.
 2. Dilute approximately to 1 L with glacial acetic acid.
 3. Dissolve 1.5 gms. of thiourea in it.
 4. Dilute upto 1 L with glacial acetic acid.
2. Glucose stock standard solution (1% w/v) :

Glucose A.R. - 1gm.

0.25% w/v aqueous solution of benzoic acid up to 100 ml.

Procedure :

Dissolve 1 gm. of glucose A.R. in approximately 75 ml. of 0.25% w/v aqueous solution of benzoic acid and dilute to 100 ml. with 0.25% w/v of aqueous solution of benzoic acid. It will give 1%w/v solution.

3. Glucose working standard solution (0.1% w/v) :

Composition :

Glucose stock standard solution - 1 ml.

Distilled water - upto 10 ml.

Procedure :

Dilute 1 ml. of glucose stock standard solution to 10 ml. with distilled water. It will give 100 mg% solution of glucose standard.

Specimen : Serum / Plasma

Wave length : 640 milli microns (red filter).

Procedure :

1. Take 3 test tubes and label them as Test (T), Standard (S) and Blank (B).
2. Proceed as follows:

Reagent	T	S	B
O-Toluidine reagent	5 ml.	5 ml.	5 ml.
Serum	0.1 ml.	-	-
Working standard	-	0.1 ml.	-
Distilled water	-	-	0.1 ml.

3. Mix thoroughly and put all the tubes on boiling water bath for exactly 8 minutes.
4. Remove and cool in a cold water bath.
5. Set the colorimeter to 100% transmission with blank at 640 milli microns wave length.
6. Determine the optical densities of T and S.
7. Determine the concentration of glucose with the formula

concentration of plasma / serum glucose in mg% =

$$\frac{\text{O.D. of test}}{\text{O.D. of standard}} \times \text{concentration of standard (100 mg\%)}$$

Normal Values :

Fasting : 70 to 110 mg%

Post Prandial: up to 130 mg%

Determination of blood glucose by GOD-POd (Enzymatic method) :

Principle :

Glucose undergoes oxidation by the action of the enzyme glucose oxidase to give gluconic acid.

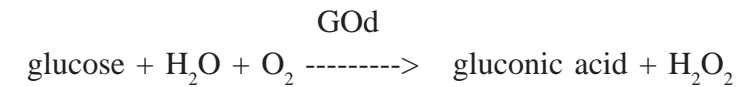

H₂O₂ formed in this reaction is cleaved into water and oxygen by the action of peroxidase enzyme.

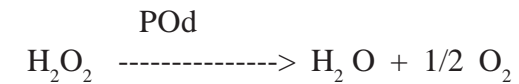

Nascent oxygen formed in this reaction reacts with 4 amino phenazone to give pink coloured compound. Colour intensity of this compound is directly proportional to the concentration of glucose in plasma / serum. Concentration of glucose in plasma / serum can be calculated by comparing with the intensity of colour developed with similarly treated standard.

Wave length : 530 nm

Specimen : Fluoride Plasma / Serum (It is to be collected within 30 minutes after collection of blood).

Reagents:

- 1) Buffer-Enzyme reagent.

Composition :

Glucose oxidase	- 650 units
Peroxidase	- 500 units
4-Aminophenazone	- 20 mg.
Sodium azide	- 30 mg.

Phosphate buffer (M/10) - 100 ml.

Method of preparation :

Dissolve GOD, P_{OD}, 4-Aminophenazone and sodium azide in 100 ml. of M/10 Phosphate buffer.

2) Phenol reagent (100 mg.dL)

Composition:

Phenol - 1 g.

0.1 N HCl - upto 1 litre.

Method of Preparation :

Dissolve 1 g. phenol in about 750 ml. of 0.1 N HCl and dilute to 1 litre with 0.1 N HCl.

Procedure :

1) Take 3 test tubes and label them as Test (T) , Standard (S) and Blank(B).

2) Pipette the reagents into the tubes as follows.

S.No.	Reagent	T	S	B
1.	Glucose reagent	3 ml.	3 ml.	3 ml.
2.	Plasma / Serum	0.02 ml.	-	-
3.	Glucose Standard	-	0.02 ml.	-
4.	Distilled water	-	-	0.02 ml.

3) Mix and keep at 37°C for 15 minutes or at lab temperature for 3 minutes.

4) Determine O.D.'s at 530 nm wave length.

5) Determine plasma glucose concentration using the formula

Plasma / Serum glucose =

$$\frac{\text{O.D. of test}}{\text{O.D. of standard}} \times \text{concentration of standard (100 mg\%)}$$

O.D. of standard

Glucose Tolerance Test :

Glucose tolerance is the ability of body tissues to utilise glucose in circulation.

Glucose tolerance test : Assessment of glucose tolerance of an individual is called as glucose tolerance test. This test is significant in the diagnosis of unknown cases of diabetes miletus.

Clinical Significance :

Glucose tolerance decreases in

1. Diabetes miletus
2. Hyperthyroidism
3. Hyperpituitarism
4. Hyperadrenalism
5. Severe liver disease
6. Severe infection (Tolerance returns to normal after infection is cured.)

G.T. increases in 1) Hypothyroidism 2) Hypopituitarism 3) Hypoadrenalism etc.

Preparation of the patient :

Patient should be kept on balanced diet containing 300 gms. of carbohydrate per day for three days prior to the test. Patient should be on fasting for 16 hours before reporting to the laboratory. Coffee or tea without sugar can be allowed in the morning. Patient is restricted from smoking or chewing tobacco till the analysis is over.

Specimens :

1. Fasting blood specimen
2. Fasting urine specimen
3. Post glucose blood specimens for fasting urine specimen negative cases in the interval of 30 minutes (4 or 5 specimens)
4. One post prandial blood specimen for fasting urine specimen positive cases
5. Post glucose urine specimen for unknown diabetics after each blood specimen (at least 2 specimens)

Procedure :

1. Collect fasting blood and urine specimens.
2. Test the fasting urine specimen by Benedict's qualitative method.
3. If the fasting urine specimen is positive for glucose, collection of post prandial blood specimen is enough.
4. If the fasting urine specimen is negative for glucose, administer glucose 75 gms. (1.75 gms./Kg body weight) dissolved in about 300 ml. of cold water. Risk of vomiting may be avoided by addition of lemon juice to the glucose solution.
5. Collect 4 or 5 post glucose blood and urine specimens at 1/2 hourly intervals.
6. Determine glucose content in each blood specimen and test qualitatively each sample of urine for sugar and ketone bodies.

Interpretation :

1. Normal glucose tolerance :

- Concentration of glucose in fasting blood specimen will be in the normal range.
- Maximum blood glucose level is reached in the first or second post glucose specimen.
- Blood glucose reaches normal within 2 hours after oral glucose administration.
- Urine sugar is absent all through out.

2. Decreased glucose tolerance:

Values in fasting blood specimens are high.

Post glucose / post prandial values are higher. Return of these values to normal is delayed.

Urine specimens are positive for Benedict's qualitative test.

3. Increased glucose tolerance:

Fasting blood sugar may be below limits. Only a small raise may be observed

in blood glucose.

Case study of a normal response :

S.No.	Time	Blood Glucose	Urine sugar
1.	Zero hour	80	-ve
2.	1/2 hour	130	-ve
3.	1 hour	140	-ve
4.	1 1/2 hour	100	-ve
5.	2 hour	80	-ve

- 1) After administration of oral glucose solution, zero hour blood glucose level is normal and zero hour urine specimen is negative for sugar.
- 2) Half an hour blood specimen shows raise in glucose level to 130 mg% and urine specimen is negative for sugar.
- 3) One hour blood specimen shows maximum raise i.e 140 mg% and urine specimen is negative for sugar.
- 4) One and half an hour blood specimen shows a fall of glucose level after maximum raise in the third sample. Urine specimen is again negative for sugar.
- 5) Two hours sample shows further fall to 80 mg% and again urine is negative for sugar.
- 6) It shows that after maximum raise within one and half an hour, blood glucose has fallen down to normal and it equals zero hour sample at the end of two hours after administration of oral glucose.

QUEST DIAGNOSTIC CENTRE, KHAMMAM

Sheet-1

Date:

Ref. by Dr. : I.P./O.P. No. Age:
Pt's Name : Sex:

Serum bilirubin } **Direct (Conjugated)**
Total
(Molly & Evelyn's) (Normal 0.20-1.00 mg/dl)

Alanine Amino transferase (SGPT) TEST CONTROL
(Kinetic Method) (Normal 5-35 U/L at 37°C)

Aspartate Amino transferase (SGOT) TEST CONTROL
(Kinetic Method) (Normal 5-40 U/L at 37°C)

Alkaline Phosphatase TEST CONTROL
(PNP Method)

Gama-Glutamyl Transpeptidase VALUE :
(Kinetic) (Normal Range 5-50 units/L at 37°C)

Serum Amylase (Normal 9-50 units/dl)
(Street & Close Method)

Serum Proteins (Bi-uret) Gms/dl
Total Proteins : (Normal range 6.0 - 8.0 mg%)
Albumin : Gms/dl
Albumin / Globulin :

Plasma prothrombin time TEST CONTROL
(Lab Normal 12 - 18 Sec)

Lactate Dehydrogenase (LDH) (Normal 200 - 400 U/L)

Creatine Phosphokinase (CPK)
[Normal: Men 24 - 195 U/L at 37°C
Women 24 - 170 U/L at 37°C]

C K (MB) Fraction (Normal: Less than 6% of total activity)

BIOCHEMIST
(Y.P. REDDY)

QUEST DIAGNOSTIC CENTRE, KHAMMAM.

Sheet-2

Ref by Dr. : Date:
Pt's Name : I.P./O.P. No. Age: Sex:

Blood Sugar (GOD / POD method)	Fasting	Post Lunch	Random
	(Normal 70 - 110 mg/dl)	(Hrs. after food)	
Urine sugar gms / dl			

Serum Triglycerides	Total Cholesterol	HDL Cholesterol	LDL Cholesterol	VLDL Cholesterol
Normal 33 - 185 mg%	130 - 220 mg%	Total Cholesterol: HDL. Cho		(Normal 4.0 - 7.5)

Blood Urea (Urease - Berthelot)	Serum Creatinine (Zeffe's Method)	Serum Uric Acid (Caraway's Method)
(Normal range 14 - 40 mg/dl)	(Female 0.7 - 1.2 mg% Male. 0.8 - 1.5 mg/dl)	(Female. 2.0 - 6.5 mg% Male. 2.5 - 7.5 mg/dl)

Serum Electrolytes			
Na+ Sodium	K+ Potassium	Ca++ Calcium	Li+ Lithium
(Normal 130 - 155 m Eq/L)	(3.5 - 5.5 m Eq/L)	(8.0 - 11.0 mg/dl)	(Normally undetectable)
S.Chloride (Cl ⁻)		S. Bicarbonate (Hco ₃ ⁻)	Phosphorus
(Normal 90 - 106 m-Eq/L)		(Normal 22 - 26 m-Eq/L)	(Normal 2.0 - 4.5 mg%)

BIOCHEMIST
(Y.P. REDDY)

Blood Urea

Urea is a principal excretory product of protein catabolism. It is water soluble and has the chemical structure-

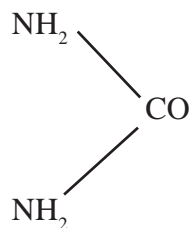

Formation of urea takes place in liver in the ureotelic organisms by sequence of reactions called as urea cycle or krebs- henseleit cycle. Average of 30 mg. of urea will be present per 100 ml. of blood and average of 30 gms. of urea is excreted through urine in 24 hours in an adult.

Determination of blood urea is significant in assessment of kidney functioning. Elevated levels are observed in pre-renal, renal and post renal conditions.

Examples of pre-renal conditions are diabetes miletus, dehydration, cardiac failure etc. Renal conditions are kidney diseases. Post renal conditions are enlargement of prostate, stones urinary tract etc. It is decreased in severe liver diseases, pregnancy, malnutrition etc.

There are different methods of determination of blood urea.

1. Diacetyl monoxime method
2. Enzymatic method
3. Titration method

Diacetyl Monoxime Method :

Principle : Urea reacts with diacetyl monoxime and thiosemicarbazide in the presence of ferric ions in a hot acidic medium to give a pink coloured compound. Concentration of urea in blood is directly proportional to intensity of pink colour. Concentration of urea in blood is determined by comparing with the colour intensity of similarly treated standard.

Ferric ions are provided by ferric chloride and acidic medium is provided by

sulphuric acid and orthophosphoric acid present in acid reagent.

Requirements :

1. Test tubes
2. 10 ml. pipette
3. 0.1 ml serological pipette
4. 100 ml. measuring cylinder
5. Water bath
6. Colorimeter

Reagents : 1. DAM - TSC Reagent

Composition :

- Diacetyl monoxime - 1gm.
- Thiosemicarbazide - 0.2 gms.
- Sodium Chloride - 9 gms.
- Distilled water up to 1000 ml

Method of Preparation :

1. Dissolve 1 gm. of Diacetyl monoxime in about 600 ml. of distilled water.
2. Dissolve 200 mg. of thiosemicarbazide in the above solution.
3. To this, add 9 gms. of sodium chloride and dissolve.
4. Dilute to 1 L with distilled water.

2. Acid Reagent :

Composition :

- Orthophosphoric acid - 10 ml.
- Sulphuric acid - 60 ml.
- 10% w/v aqueous ferric chloride solution - 1ml.
- Distilled water upto 1 litre.

Method of Preparation :

1. Add 10 ml. orthophosphoric acid and 60 ml. of sulphuric acid to about 750 ml. of distilled water.
2. Cool and add 1 ml. of 10% w/v ferric chloride solution.
3. Dilute the above solution to 1 litre with distilled water.

3. Stock Urea Standard Reagent (1% w/v) :

Composition :

Dry urea - 1 gm.

0.2 % w/v benzoic acid aqueous solution upto 100 ml.

Method of preparation :

Dissolve 1 gm. Urea in 75 ml. of 0.2% w/v benzoic acid aqueous solution and dilute to 100 ml. with 0.2% w/v benzoic acid solution.

4. Urea Working Standard (50 mg%) :

Composition :

Stock urea standard - 5 ml.

0.2% w/v benzoic acid aqueous solution up to 100 ml.

Method of preparation :

Dilute 5 ml. of stock urea standard to 100 ml. with 0.2% w/v aqueous benzoic acid solution. This will be stable for 1 year in a refrigerator.

Wave length : 520 milli microns (green filter)

Procedure :

1) Prepare Protein free blood filtrate (T) as follows :

Add 3.5 ml. of distilled water, 0.2 ml. of 2/3 N sulphuric acid and 0.2 ml of 10% sodium tungstate solution to 0.1 ml. of blood, mix and centrifuge after 5 minutes. Take supernatant in a test tube and label as test (T).

2. Give similar treatment to 0.1 ml. of urea working standard, take the supernatant in a test tube and label as standard (S).

3. Give similar treatment to 0.1. ml. of distilled water, take supernatant in a test tube and label as blank (B).

4. In the tubes labeled as T, S and B take the reagents as follows :

	T	S	B
Supernatant	2 ml.	2 ml.	2 ml.
DAM-TSC reagent	3 ml.	3 ml.	3ml.
Acid reagent	3 ml.	3ml.	3ml.

5. Mix and plug the tubes with cotton.

6. Heat in a boiling water bath for 15 min. and cool.

7. Set the colorimeter to 100% transmission using blank at 520 nm wave length.

8. Determine the optical densities of standard and test

9. Determine the concentration of blood urea using the formula

concentration of urea in blood =

$$\frac{\text{O.D. of test}}{\text{O.D. of standard}} \times \text{concentration of standard (50 mg\%)}$$

Normal Values : 15-45 mg%.

$$\text{Blood urea Nitrogen} = \frac{\text{Blood urea}}{2.14}$$

Enzymatic method (Berthlot reaction method) :

Principle : Urea in the blood is converted to ammonia and CO₂ by the action of urease enzyme. Ammonia reacts with phenol in the presence of hypochlorite to form indophenol. Indophenol gives blue colour compound with alkali. Concentration of blood urea is directly proportional to the colour intensity. Concentration of blood urea can be determined by comparing with colour intensity of similarly treated standard.

Requirements :

1. Test tubes
2. Graduated pipettes
3. Water bath
4. Colorimeter

Reagents :

1. Urease reagent

Composition :

Urease - 1000 units

Phosphate buffer upto 100 ml.

Method of preparation :

Dissolve 1000 units of urease in about 75 ml. of phosphate buffer and dilute to 100 ml. with phosphate buffer (pH 7, 0.05 M)

2. Phenol reagent :

Composition :

Phenol - 5g.

Sodium Nitroprusside - 0.025 g.

Distilled water up to 500 ml.

Method of preparation :

Dissolve 5 g. phenol and 0.025 g. of sodium nitroprusside in about 450 ml. of distilled water and make the volume to 500 ml. with distilled water.

3. Hypochlorite Reagent :

Composition : Sodium hypochlorite - 0.21 g.

Sodium hydroxide - 2.5 g.

distilled water up to 500 ml.

Method of preparation :

Dissolve 0.21 g. of sodium hypochlorite in 2.5 g. of sodium hydroxide in about 450 ml. of distilled water and dilute to 500 ml. with distilled water.

4. Standard Urea Nitrogen 20 mg%.

Storage of Reagents : Reagents should be stored in refrigerator at 2-8°C. They are stable at this temperature for 3 months.

Wave length : 546 nm (green filter)

Procedure :

1. Take 3 test tubes and label them as T, S and B.

2. Take reagents in the tubes as follows:

Reagents	T	S	B
Urease reagent	0.5 ml.	0.5 ml.	0.5 ml.
serum / plasma	0.02 ml.	-	-
standard urea nitrogen	-	0.2 ml.	-

3. Mix and keep at 37°C for 10 minutes.

4. Now, proceed as follows:

	T	S	B
Phenol reagent	1 ml.	1 ml.	1 ml.
Hypochlorite reagent	1 ml.	1 ml.	1 ml.

5. Mix and keep the tubes at 37°C for 10 minutes.

6. Add 5 ml. of distilled water to each tube and mix thoroughly.

7. Set the colorimeter to 100% transmission with blank at 546 nm wavelength.

8. Determine the optical densities of test and standard.

9. Determine the concentration of blood urea nitrogen and blood urea with formulae.

$$\text{Blood urea nitrogen} = \frac{\text{O.D. of test}}{\text{O.D. of standard}} \times 20 \text{ mg\%}.$$

Blood urea = Blood urea nitrogen X 2.14

Normal Values :

Blood urea nitrogen = 5 to 21 mg %.

Blood urea = 11 to 45 mg%.

Titration method :

Requirements :

1. Oxalated tube
2. Centrifuge
3. Burette
4. Porcelain tile

Reagents :

1. 10% w/v trichloro acetic acid
2. 5% mercuric chloride
3. Saturated sodium carbonate solution.

Procedure :

1. Take 7-10 ml. blood in oxalated tube and rotate.
2. Add equal volume of trichloro acetic acid, centrifuge and take supernatant.
3. Titrate 5 ml. of protein free blood filtrate prepared in the above step with 5% mercuric chloride solution run from a burette. Initially, run 1.5 ml. of 5% mercuric chloride immediately and then proceed slowly. When the end point is reaching, glass rod dipped in the titration mixture on touching saturated sodium carbonate drop on the tile produces yellow colour. At the end point, reddish brown precipitate is produced.

4. Determine the concentration of urea with the formula :

Concentration of blood urea = (volume of mercuric chloride X 40)- 60 mg%.

Normal Values : 10 to 40 mg%

Serum Creatinine:

Creatinine is waste product of creatine metabolism. It arises in the body

from spontaneous break down of creatine phosphate.

Normal values range from 0.6 to 1.5 mg%. Daily output is 1.5 to 3 gms.

Serum creatinine is increased in renal failure. Elevated levels are also observed in diabetes miletus, fever, heart stroke, shock and obstruction of urinary tract.

Name of the method :

Alakaline picrate method (Jaffe's reaction) :

Principle : Creatinine reacts with picric acid in alkaline medium to produce reddish yellow coloured compound. Alkaline medium needed for the reaction is provided by sodium hydroxide. Concentration of creatinine is directly proportional to the colour intensity of reddish yellow colour. Concentration of creatinine in the specimen can be determined by comparing with colour intensity produced in similarly treated standard.

Requirements :

1. Test tubes
2. Serological pipettes
3. Volumetric pipettes
4. Centrifuge tubes
5. Centrifuge
6. Colorimeter

Reagents :

1. 0.91% w/v picric acid solution
2. Creatinine stock standard solution (100mg%)

Composition :

Creatinine 1 gm.

0.1 N HCl up to 1 litre.

Method of Preparation :

Dissolve 1 gm. of pure and dry creatinine in 0.1 N HCl and dilute to 1 litre volume with 0.1N HCl.

3. Creatinine working standard solutions (1mg%, 5mg% and 10mg%)

1 mg% solution :

Composition : Stock creatinine standard solution - 1 ml.

0.01 N HCl up to 100 ml.

5 mg% solution.

Composition : Stock creatinine standard solution - 5 ml.

0.01 N HCl up to 100 ml.

10 mg% solution

Composition : Stock creatinine standard solution - 10 ml.

0.01 N HCl up to 100 ml.

4. 10% w/v sodium hydroxide solution

Composition :

Sodium hydroxide - 10 gms.

Distilled water upto 100 ml.

5. 10% w/v sodium tungstate solution

Composition :

Sodium tungstate - 10 gms.

Distilled water upto 100 ml.

6. 2/3 N sulphuric acid

Composition :

Concentrated sulphuric acid - 2 ml.

Distilled water upto 100 ml.

7. Alkaline picrate reagent :

Composition:

Picric acid reagent - 4 parts

10% NaOH - 1 part

This reagent is stable for 1 day only.

Stability of reagents : Stock picric acid standard and 10% sodium hydroxide solution are stable at room temperature. Working standards are stable at 2 to 8°C.

Specimen : Serum

Wave length : 520 nm (green filter)

Procedure :

1. Prepare protein free blood filtrate as follows:

Distilled water - 3 ml.

Serum - 1. ml.

2/3 N H₂SO₄ - 0.5 ml.

10% Sodium tungstate solution - 0.5 ml.

Centrifuge and take supernatant.

2. Pipette in to the tubes labelled as T, S and B as follows

	T	S	B
Distilled water	3 ml.	3 ml.	5 ml.
Filtrate	2 ml.	-	-
Working standard	-	2 ml.	-
Alkaline picrate	1 ml.	1 ml.	1 ml.

3. Mix and keep at room temperature for 20 minutes.

4. Set the colorimeter to 100% Transmission with blank.

5. Determine the O.D.s of test and different standards.

6. Determine concentration of unknown using the formula

Concentration of serum creatinine =

$$\frac{\text{O.D. of Test}}{\text{O.D. of Standard}} \times \text{Concentration of standard mg\%}$$

Normal values:

Serum : Males: 0.9 to 1.5mg%
Females : 0.8 to 1.2 mg%

Serum Uric Acid:

Uric acid is the end product of purine metabolism. Chemical structure is 2,6,8 trihydroxy purine. Liver is the chief site of synthesis. Blood contains 2-6 mg of uric acid for 100 ml. Daily output is 0.75 to 1 g.

Clinical Significance :

Its value in blood is increased in

1. Gout
2. Leukaemia
3. Pneumonia
4. Arteriosclerosis with hypertension.
5. Cardiac decompensation.

Serum uric acid:

Principle : Uric acid reacts with phosphotungstic acid in alkaline medium to form a blue coloured complex. Concentration of uric acid is directly proportional to the colour intensity. Concentration of uric acid in serum is determined by comparing with similarly treated uric acid standard. Alkaline medium is provided by sodium carbonate.

Name of the method : Henry Caraway

Requirements:

1. Test tubes

2. Serological tubes

3. Centrifuge tubes

4. Colorimeter

1. Sodium tungstate 10% w/v

Composition:

Sodium tungstate - 10g.

Distilled water up to 100 ml.

Method of preparation:

Dissolve 10g. of sodium tungstate in about 75 ml. of distilled water and dilute to 100 ml. with distilled water.

2. Sulphuric acid 2/3 N.

Composition :

Concentrated sulphuric acid - 2 ml.

Distilled water upto 100 ml.

Method : Add 2 ml. of concentrated sulphuric acid to about 75 ml. of distilled water with stirring and dilute to 100 ml. with distilled water and standardize.

3. Sodium Carbonate 10% w/v

Composition:

Anhydrous sodium carbonate - 10g.

Distilled water upto 100 ml.

Method of preparation :

Dissolve 10 g. of sodium carbonate anhydrous in 75 ml. of distilled water and dilute to 100 ml. with distilled water.

4. Phosphotungstic acid:

Requirements :

Sodium tungstate - 100g

Disodium hydrogen phosphate (anhydrous) - 20g.

Concentrated sulphuric acid - 25 ml.

Distilled water upto 1 litre.

Method of preparation :

1. Dissolve 100g. of sodium tungstate and 20g. of anhydrous disodium hydrogen phosphate in 200 ml. of distilled water.
 2. Add 25 ml. of concentrated sulphuric acid to about 75 ml. of distilled water.
 3. Pour acid solution slowly in to the solution prepared in 1st step and mix.
 4. Boil for one hour with reflux condensor.
 5. Cool and dilute to 1 litre with distilled water.
 6. Store in amber coloured bottle
5. Stock uric acid standard (100 mg%)

Composition :

Lithium carbonate - 60 mg.

Uric acid - 100 mg.

Formalin - 2 ml.

50% acetic acid - 1 ml.

Distilled water upto 100 ml.

Method of preparation :

1. Dissolve 60 mg. of Lithium carbonate in about 40 ml. of distilled water.
 2. Add 100 mg. of uric acid and warm gently.
 3. Add 2 ml. formalin and 1 ml. of 50% acetic acid
 4. Dilute to 100 ml. with distilled water
- Store in amber coloured bottle at 2 to 8°C.
6. Working phosphotungstic acid solution

Composition:

Stock phosphotungstic acid solution - 5 ml.

Distilled water upto 100 ml.

Method of preparation :

Dilute 5 ml. of stock phosphotungstic acid to 100 ml. volume with distilled water.

7. Working uric acid standard (5mg%)

Composition :

Stock uric acid standard solution - 5 ml.

Distilled water upto 100 ml.

Method of preparation :

Dilute 5 ml. of stock uric acid solution to 100 ml. with distilled water.

Wave length : 660 nm (Red filter)

Specimen : Serum

Procedure :

1. Take three test tubes and label them as T, S and B
2. Take the reagents as follows

Reagent	T	S	B
Distilled water	3.5 ml.	3.5 ml.	4 ml.
Serum	0.5 ml.	-	-
Uric acid (standard)	-	0.5 ml.	-
Sodium tungstate 10% w/v	0.5 ml.	0.5 ml.	0.5 ml.
Sulphuric acid 2/3 N	0.5 ml.	0.5 ml.	0.5 ml.

This step gives protein free serum filtrate and similarly treated standard and blank.

3. Mix, centrifuge after five minutes and take into test tubes labelled as T, S

and B as follows

	T	S	B
Supernatant	3 ml.	3 ml.	3 ml.
Sodium Carbonate	1 ml.	1 ml.	1 ml.

- Stand for 10 minutes and add 1 ml. of phosphotungstic acid to each tube.
- Mix well.
- Set the colorimeter to 100% transmission with blank at 660 nm wavelength (red filter).
- Determine the O.D.s of test and standard.
- Determine the concentration of serum uric acid with formula.

Concentration of serum uric acid =

$$\frac{\text{O.D. of test}}{\text{O.D. of standard}} \times 5 \text{ mg\%}$$

Normal values : 3 to 7 mg%

SUMMARY

Blood sugar determination is significant in diagnosis and assessment of diabetes miletus.

Some of the methods of determination of blood sugar are folin and wu method, O-Toluidine method and GOd - POd method. Glucose tolerance test is significant in the diagnosis of unknown cases of diabetes miletus.

Determination of blood urea is significant in assessment of Renal functioning. Different methods of determination of blood ureas are Diacetyl Monoxime method, Enzymatic method and Titration method. Determination of Serum creatinine is significant in diagnosis of Renal functioning, cardiac functioning etc. It is determined by Alkaline Picrate method.

Determination of serum uric acid is significant in determination of Gout, Leukaemia, etc. It is determined by Henry-Caraway method.

Essay Questions

- What are different methods of blood glucose determination? Write about folin and wu method.
- Write about determination of blood glucose by O-Toluidine method.
- How do you determine blood glucose by GOD-POD method?
- Write about glucose tolerance test (GTT).
- Explain the method of determination of blood urea by diacetyl monoxime method.
- Write about enzymatic method of determination of blood urea.
- Describe determination of serum creatinine by alkaline picrate method.
- How do you determine serum uric acid by Henry-Caraway method?

Short Answer Questions

- What is meant by renal threshold value for blood sugar?
- What is diabetes miletus?
- Mention normal values of fasting blood sugar by different methods.
- Define a) Hyper glycaemia b) Glycosuria.
- What is the principle of blood sugar determination by Folin & Wu method?
- Mention the uses of a) 10% sodium tungstate b) 2/3 N sulphuric acid in blood sugar determination by Folin and Wu method.
- Give the uses of a) Alkaline copper tartarate solution b) Phsophomolybdc reagent in blood sugar determination by Folin & Wu method.
- Write the composition of glucose stock standard solution.
- How do you prepare (0.1% w/v) glucose working standard from 1% w/v glucose stock standard solution?
- Give the principle of blood sugar determination by O-Toluidine method.
- Write the composition of O-Toluidine reagent.
- Give the principle of blood sugar determination by GOd-POd method.

13. Mention the wavelength selected for blood sugar determination by a) O-Toluidine method b) GOD-POD method.
14. Give the list of specimens required for glucose tolerance test.
15. How do you avoid the risk of vomiting while giving glucose to patient on fasting during G.T.T.?
16. When do you collect post glucose blood specimens in G.T.T. and how many?
17. What is normal glucose tolerance in G.T.T.?
18. What is decreased glucose tolerance in G.T.T.?
19. Give the clinical significance of blood urea determination.
20. What is urea? Give its chemical structure.
21. Write the principle of determination of blood urea by diacetyl monoxime method.
22. Mention the wave lengths selected for determination of blood urea by a) Diacetyl monoxime method b) Berthelot reaction method.
23. Write the principle of determination of blood urea by enzymatic method.
24. Name the enzyme reagent used in blood urea determination by Berthelot reaction method and give its composition.
25. Write the clinical significance of serum creatinine determination.
26. Give the principle of serum creatinine determination by alkaline picrate (Jaffe's reaction) method.
27. Write the composition of Alkaline picrate reagent.
28. Give the stability aspects of stock picric acid standard and creatinine working standard reagents in serum creatinine determination by Jaffe's reaction method.
29. Mention the normal values of serum creatinine for male and female.
30. What is uric acid?
31. Give the normal values of serum uric acid.
32. Write the clinical significance of determination of serum uric acid.

33. Give the principle of determination of serum uric acid by Henry-Caraway method.
34. How do you prepare 500 ml. of 2/3 N sulphuric acid from concentrated sulphuric acid (normality of concentrated sulphuric acid = 36)?
35. Write the composition of stock uric acid reagent (100 mg%).
36. How do you prepare 5 mg% working uric acid standard solution from stock uric acid standard solution?
37. Give the wave lengths for determination of a) Serum creatinine b) Serum uric acid.

15. VITAMINS AND MINERALS

i. Vitamins :

Vitamins are organic substances which in trace quantities are essential for life.

Classification : There are two classes of vitamins depending on their solubility properties.

There are 1) Water soluble vitamins 2) Fat soluble vitamins.

Water soluble vitamins : They are

- Thiamine (Vitamin B₁)
- Riboflavin (Vitamin B₂)
- Nicotinic acid (CoenzymeII, NADP)
- Pantothenic acid (eocnzyme A)
- Pyridoxine
- Biotin
- Folic acid
- B₁₂(Cynacobalamin)
- Lipoic acid
- Ascrobic acid (Vitamin C)
- Miscellaneous

Thirmine (Vitamin-B₁) : It is also called aneurin. It occurs in living cells in its active eoenzyme form - Thirmine pyrophosphate (TPP). It participates in decarboxylation of α -keto acids and forms acetylc coenzyme A. It is assayed by fluorimetry, because it exhibits fluorescence.

Sources : This vitamin is adequately available in many natural foods. It is available in the germ of cereals, brans, egg yolks, yeast extracts, peas, beans and nuts.

Thiamine is biologically synthesized from two precursors.

Daily requirement : 1-3 mg. of this vitamin is required generally in human beings.

Deficiency diseases : Vitamin B₁ deficiency causes the following symptoms in human being, they are - loss of appetite, gastrointestinal disturbances, muscular weakness, pain in arms and legs, decreases of B.P. Severe deficiency affects

entire nervous system leading to BeriBeri. In pigeons deficiency of this vitamin causes polyneuritis.

Ribo flavin (Vitamin B2): It is also called as Lactoflavin. It is a yellow crystalline solid.

Sources : It is synthesized by all green plants, most bacteria and fungi. Sources of this vitamin are yeast green vegetables, liver, wheat germ, egg yolk, milk, meat, fish etc. In low quantities it is found in polished rice, retina of eyes and potatoes.

Daily requirement : Average healthy adult human requires 2-3 mg of riboflavin per day.

Deficiency diseases: Deficiency of riboflavin in man causes 1) Inflammation of tongue 2) Cheilosis - cracking of lips and corners of mouth. It is necessary for growth and health.

Nicotinic acid : It is called as Pellegra preventing factor. It recognized as essential food factor of 1913. It was first prepared by oxidation of Nicotine. It was isolated from yeast after 1913.

Sources: Its general sources are pork, lamb, beef livers, hog kidneys, yeasts, beef tongue, hearts, lean meats, wheat germ, peanut meal and green peas. Human and other animals can prepare it from tryptophan.

Daily requirement : Its requirement is about 13 mg/day.

Deficiency diseases: Serious deficiency of Niacin or Tryptophan can cause pellagra. In severe cases of pellagra, psychoses sometimes develops. Niacin is also effective as lipid lowering agent in the treatment of certain cases of hyperlipidaemia.

Pantothenic acid : This vitamin is a structural component of coenzyme-A. Its function is to serve as carrier of acyl groups in enzymatic reactions.

Sources : Its occurrence is wide spread and hence it was called pantothenic acid, in Greek which means from every where. It is synthesized by most green plants and micro organisms.

Daily requirements : Its daily requirement is about 5 mg/day.

Deficiency diseases : Clinical cases of pantothenic acid deficiency do not develop commonly. They may arise in combination with deficiency of other B-complex vitamins.

Pyridoxine : It is also called Vitamin-B₆. Pyridoxine is biologically converted into pyridoxal and pyridoxamine. Active coenzyme forms are pyridoxal phosphate and pyridoxamine phosphate.

Sources : Whole grain cereals, peanuts, corn, meat, poultry and fish. It is synthesized by plants and some microorganisms.

Daily requirements: Its daily requirement is about 1-2 mg/day.

Deficiency diseases : In some infants, its inadequate supply in diets lead to epileptic like seizures and can be controlled by treatment with pyridoxine. Pyridoxine deficiency also causes hypochromic anaemia and they can be cured by pyridoxine therapy.

Biotin : It is also called Vitmain-H. Biotin was first isolated from a liver concentrate. Biotin is made by intestinal bacteria.

Sources : It is available in small quantities in almost all higher animals. It is available in high concentrations in liver, kidney, eggs and yeast. It is also found as free or combined form in vegetables, grains and nuts. It is found in alfalfa, string beans, spinach and grass.

Daily requirement : Minimal requirement of this vitamin is not established because quantity of vitamin provided by microorganisms can not be determined, however it is 100 mg/day.

Deficiency states: Biotin deficiency is caused by prolonged feeding of raw egg white. Raw egg white contains a protein called avidin. It has property of binding with biotin and preventing its absorption from intestine.

Folic acid : Folic acid is a Pteridine derivative synthesized by bacteria. It was first reported occurring in leaves and foliage of spinach.

Sources: Leaves and foliage of spinach, whey, mushrooms, liver, yeast, bone marrow, soyabeans and fish meal. It is synthesized by bacteria.

Daily requirement : Its daily requirement is 50 mg/day.

Deficiency states : Folic acid deficiency causes impairment in the biosynthesis of purines and pyrimidine thymine. Its deficiency in mammals results in growth failure and different forms of anaemia.

Cyanocobalamin (Vitamin B₁₂) : It is a cobalt containing substance. It is essential for development of epithelial cells. It is required in formation and function of myelinated nerve fibre.

Sources : It can not be synthesized by plants & animals. It is synthesized by certain micro organisms. Liver and other non vegetarian food contain B₁₂.

Daily requirement : It is only required in trace quantities by animals. It is required in quantities of 1 micro gms/day.

Deficiency diseases : Deficiency of Cyanocobalamin causes pernicious anaemia and peripheral neuritis. Vitamin B₁₂ is essential for normal maturation and development of erythrocytes. Pernicious anaemia is caused due to deficient supply of this vitamin or deficient absorption of this vitamin in intestine. A specific glycoprotein called intrinsic factor present in gastric juice helps in carriage of this vitamins to intestinal cells by binding to this vitamin. From here, it is transported to peripheral tissues by binding to other proteins called transcobalamins.

Lipoic acid : It is also called as "acetate replacement factor. It is also known as 'Protogen'.

Sources : natural foods.

Daily requirement : Not established

Deficiency symptoms : Not yet established

Ascorbic acid : It is also called as vitamin 'C'.

Sources : Amla, Citrus Fruits, Tomatoes, Grapes etc.

Daily requirement : 35 – 80 mg. (Adults – 45 mg.)

Deficiency symptoms : Scurvy in adults, scurvy in infants.

Fat soluble vitamins :

Fat soluble vitamins are A, D, E and K. They are soluble in Fat. Bile salts facilitate their absorption through GIT.

Vitamin A : Vitamin A is useful for maintenance of integrity of epithelial tissue. It is necessary for healthy skin and general growth also.

Sources : Yellow vegetables and fruits, Cod liver oil, shark liver oil.

Daily requirements : 1500 – 5000 I.U. (adults 5000 I.U.)

Deficiency symptoms : Xerophthalmia, Keratomalacia etc.

Excess symptoms : Sluggishness, Headache, roughening of skin etc.

Vitamin D : D vitamins are a group of compounds. They are all steroids.

Sources : Liver of fish, eggs, butter, milk etc.

Daily requirements : 200 – 400 I.U. (adults – 200 I.U)

Deficiency symptoms : Rickets in children and osteomalacia in adults.

Vitamin E : E vitamins are also called Tocopherols.

Sources : Eggs, meat, liver, fish, corn oil, cotton seed oil etc.

Daily requirements : Adults – 25 – 30 mg.

Deficiency symptoms : Haemolysis, Anaemia, Hepatic necrosis etc.

Vitamin K : It is essential for coagulation of blood. It catalyses the synthesis of prothrombin by the liver.

Sources : Green leafy vegetables, cauliflower, carrots, milk etc.

Daily requirement : Average diet contains quantities adequate for adults. Its deficiency is not reported in healthy individuals. It is reported in infants and new born with mothers diet of low quantities of Vitamin K.

Deficiency symptoms : Haemorrhagic conditions.

Minerals

Minerals present in the body are supplied through diet. They can be classified into;

- (1) Principal mineral elements :
They are sodium, potassium, Calcium, Phosphorous, Magnesium, Chlorine and sulphur. They are seven in number.
- (2) Trace Elements : Minerals present in small quantities in the body are called trace elements. On the basis of essentiality, they can be classified into.
 - (A) Essential trace elements :
Iron, Iodine, Copper, Cobalt, Fluorine etc.
 - (B) Possibly essential trace elements :
Nickel, tin, Vanadium etc.
 - (C) Non-essential trace elements :- Aluminium, Boron, Lead, Mercury etc.

Sodium : It is the major cation of extra cellular fluid. It is required for maintaining :

- (1) Neuromuscular function
- (2) Heart beat initiation
- (3) Cell permeability
- (4) normal water balance etc.

Sources : Bread, Cheese, Table salt, Carrots, Cauliflower etc.

Daily requirements : Adults – 5 – 15 gms.

Clinical significance : In Hyponatraemia, less values than normal are observed. In Hypernatremia, High values are present.

Potassium : It is the major cation of intracellular fluid.

It is useful for maintaining :

- (1) Cardiac Muscle activity
- (2) Osmotic pressure
- (3) Acid-base balance
- (4) Water retention
- (5) Protein Biosynthesis in ribosomes.

Sources ; Chicken, Beef, Liver, Bananas etc.

Daily requirements : About 4 grams.

Clinical significance : Deficiency is called Hypokalaemia and excess is called Hyperkalaemia, Hypokalaemia causes injury to myocardium and kidneys etc. Hyperkalemia is seen in Renal failure, severe dehydration and Addison's disease etc.

Calcium : Calcium is essential along with Phosphorous for formation of Bones and Teeth. Ionic calcium is essential for ;
(A) Blood Coagulation (B) Nervous excitability
(C) Neuromuscular transmission etc.

Sources : Milk, Cheese, egg, Cabbage, Cauliflower etc.

Daily requirement : 0.35 – 1.2 grams (adults – 0.8 gms.)

Deficiency diseases : Tetanus, Rickets, Osteomalacia, Osteoporosis, Renal rickets etc.

Phosphorous : It is essential along with calcium for formation of bones and teeth.

Sources : Milk, Cheese, egg yolk, meat etc.

Daily requirements : 240 – 1200 mg. (adults – 800 mg.)

Deficiency symptoms : Values are low in rickets, renal rickets, Hyperparathyroidism etc.

Magnesium : 70% of body magnesium content is combined with calcium and phosphorous.

Sources : Milk, eggs, cabbage, cauliflower etc.

Daily requirements : 100 – 300 mg. (Adults – 200 – 300 mg.)

Deficiency symptoms : Depression, Muscular weakness, convulsions etc.

Chlorine : It is essential as Chloride of Sodium for acid base balance. Chloride ion is also essential for (A) Water balance (B) Osmotic regulation (C) Production of HCl (D) Activation of Amylase.

Sources : Sodium Chloride

Daily requirements : 5 – 20 gms. (Adults 10 – 20 gms.)

Deficiency Symptoms : Diarrhoea, sweating, vomiting etc.

Sulphur : Sulphur is present in Sulphur containing Amino acids – Cysteine and Methionine.

Sources : Cysteine and methionine.

Clinical significance : Increased in renal impairment, Pyloric and intestinal obstruction, Leukaemia etc.

Iron : Total Iron present in normal adult body is about 5 grams. It is present in Haemoglobin, Myoglobin and plasma.

Sources : Liver, Heart, Kidney, Egg, Fish etc.

Daily requirement : 10 – 18 mg. (Adults – 10 mg.)

Deficiency symptoms : Anaemia

Excess Symptoms : Siderosis, Nutritional siderosis and Haemochromatosis etc.

Iodine : Iodine is required for formation of Thyroxine and Triiodo Thyronine.

Sources : Sea water, sea foods, vegetables etc.

Daily requirements : 100 – 200 micro gms.
(Adults 100-150 micro gms.)

Deficiency diseases : (1) Goitre in adults (2) Cretinism in children

Fluorine : In trace quantities it is essential for development of teeth and bones.

Sources : Drinking water

Daily requirement : Drinking water containing 1 – 2 ppm.

Deficiency symptoms : Dental caries in children.

Excess symptoms : Dental fluorosis, Hypercalcification of bones etc.

Summary

Vitamins are organic substances essential for life. They are classified into (1) Water soluble Vitamins (2) Fat soluble Vitamins. Water soluble vitamins are Thiamine, Riboflavin, Nicotinic acid, Pantothenic acid, Pyridoxine, Biotin, Folic acid, Cynacobalamin, Lipoic acid, Ascorbic acid etc. Fat soluble vitamins are A, D, E and K.

Minerals of body can be classified into principal mineral elements and trace mineral elements. Principal mineral elements are seven. They are Sodium, Potassium, Calcium, Phosphorous, Magnesium, Chlorine and Sulphur. Trace elements can be classified into essential, possible essential and non-essential elements.

Essay questions

- 1) Classify vitamins and minerals.
- 2) Write about Fat soluble vitamins.
- 3) Discuss various water soluble vitamins.
- 4) Write note on principal mineral elements.

Short answer questions

- 1) Write the sources of A & D.
- 2) Mention the daily requirements of A & D.
- 3) Write the deficiency diseases of Vitamin A.
- 4) What are deficiency symptoms of E & K.
- 5) What are principal minerals.
- 6) Write the functions of Sodium.
- 7) What is Hyperkalaemia ?
- 8) Name the conditions of Hyponatraemia.
- 9) Name the proteins of body in which iron is present.

GLOSSARY

Ammonia - A gas with structure NH_3 , product of decomposition of urea.

Amylase - Enzyme responsible for conversion of starch into sugar.

Anorexia - Loss of appetite.

Arteries - Blood vessels in the body, which carry oxygenated blood.

Arteriosclerosis - Degenerative arterial change associated with advancing age.

Asepsis - State of freedom from living micro organisms.

Aseptic - Free from living microorganisms.

Autoclaving - Moist heat method of sterilisation with autoclave.

Bilirubin - a pigment present in bile juice.

Blood - Fluid connective tissue consisting of 55% plasma and 45% cells.

Capillaries - Minute vessels of blood in the body.

Conception - Pregnancy

Enzyme - Biocatalyst.

Esbach's albuminometer - Instrument used in quantitative determination of urine proteins.

Fasting - Abstaining from taking food.

Flame photometer - An instrument used to determine concentration of electrolytes by Icterus index - Index used to measure concentration of bilirubin.

Folin & Wu tube - Tube used in blood sugar determination by Folin & Wu method.

Glomerulonephritis - Inflammation of glomeruli of kidney.

Gout - A disease in which deposition of sodium biurate in the cartilages of Joints,

Ears etc. takes place and big toe becomes acutely swollen and painful.

Haematoma - Swelling filled with blood.

Haematology - Study of blood.

Histopathology - Science dealing with preparation and processing of tissue for microscopic examination for diagnosis of disease.

Hypertension - Blood pressure above normal range. Resting diastolic pressure of 160 mm Hg and resting diastolic pressure of 100 mm Hg.

Hypo - Sodium thiosulphate.

Insulin - A hormone produced by B-cells of Islets of langerhans of pancreas. It has role in carbohydrate metabolism.

Veins - Blood vessels in the body which carry deoxygenated blood.

Leukaemia - A malignant proliferation of leukopoietic tissues usually producing an abnormal increase in the leukocyte count with immature cells among them.

Litmus paper - Strip of paper for determining reaction of a solution.

Liver - Main metabolic organ of body, which produces digestive juice (bile juice) also.

Neonate - New born (upto one month).

Nephropathy - Kidney disease.

Nessler tube - A glass tube with flat bottom and with a mark etched around. It is generally used in qualitative comparative methods.

Opalescence - Turbidity.

pH - Negative logarithm of H^+ ion concentration. pH <7 indicates acidity. 7 is neutral pH. pH >7 indicates alkalinity.

Pneumonia - Inflammation of lungs with production of alveolar exudate.

Pyelonephritis - Renal infection spreading from plevis to cortex of kidney. Origin of infection is usually from ureter and below or from blood.

Qualitative analysis - Analysis used to determine the nature of substance.

Quantitative analysis - Analysis used to determine concentration.

Recrystallisation - Process of conversion of dissolved substance.

Refining - Purification.

Serology - Branch of Science dealing with Sera.

Starvation - Deprivation of food.

Sterilisation - Process of killing or eliminating all the living micro organisms.

Sublimation - Conversion of solid to gas without passing through liquid state and vice versa.

Toxaemia - Generalised poisoning of body by the products of micro organisms.

Urochrome - Pigment in urine responsible for normal amber to yellow colour of urine.

REFERENCES

1. Text book of Medical Laboratory Technology by
Praful B. Godkar
2. Biochemistry by *Lehninger*
3. Biochemistry by *Harper*
4. Biochemistry by *Rama Rao*
5. Medical Lab Technology by *Ramnik Sood*
6. Medical Lab Technology Manual by *K.M. Samuel*
7. Indian Pharma Copoeia
8. Bentley's Pharmaceutical Chemistry
9. Pharmaceutical Chemistry by quadry.
10. Clinical Biochemistry by *Harold Varley*
11. Vogel's Text Book of Quantitative Inorganic Analysis
12. Chemical methods of instrumental analysis by *B.K. Sarma*
13. Chemistry of Organic Natural Products by *O.P. Agarwal*
14. Pharmaceutical Chemistry by *M.L. Schroff*
15. Dispensing for Pharmaceutical students by *Cooper & Gunn*
*and My Learnings from Dr. C.K. Kokate, Dr. M.C.P.,
Dr.A. V.N. Appa Rao and Dr. D.R.K.*