

**A Text book of Auto Transmission and Electrical systems
(a text book for +2 Vocational Education)**

Author

K.S Raghu ram

Lecturer in engineering

Dept.of Vocational Education

Dr.V.S.Krishna Govt. Jr.college(Boys)

VISAKHAPATNAM

Editor

P.L.N Prakasa rao patnaik

Lecturer in Engineering

Dept.of Vocational Education

Govt.Jr.college

AMADALAVALLASA

contents

- 1.0 Clutch
 - 1.1 Necessity of clutch in automobiles
 - 1.2 Construction and working of a single plate, multiplate, centrifugal and semi-centrifugal clutch
- 2.0 Gear Box
 - 2.1 Necessity of gear box in automobiles
 - 2.2 Construction and working of a sliding mesh, constant mesh and synchro mesh gear box
- 3.0 Universal Joints and Propeller Shaft
 - 3.1 Necessity of Universal Joints & Propeller Shaft
 - 3.2 Construction and working of cross or spider, yoke, ball and Trunion and constant velocity type, universal type
 - 3.3 Construction and working of enclosing type and hollow type propeller shaft
 - 3.4 Construction and working of slip joint, hotchkis drive, torque tube drive
- 4.0 Differential Unit
 - 4.1 Necessity of differential
 - 4.2 Construction and working of a differential
 - 4.3 Differential lock and self locking differential
- 5.0 Front and Rear Axles
 - 5.1 Necessity of Front & Rear axle
 - 5.2 Construction and working of live and dead axles
 - 5.3 Construction and working of different types of stub axles
 - 5.4 Construction and working of semi floating, three quarter floating and full floating rear axles
- 6.0 Suspension System
 - 6.1 Function of suspension system in automobiles
 - 6.2 Construction and working of Hydraulic and Telescopic shock absorbers
 - 6.3 Coil spring mountings
- 7.0 Wheel and Tyres
 - 7.1 Function of Wheel & Tyres
 - 7.2 Construction and working of Disc and spoked wheel
 - 7.3 Types of rims and their construction
 - 7.4 Construction & properties of tyres
 - 7.5 Different tyre treat pattern
 - 7.6 Specifications of a tyre
 - 7.7 Tyre rotation
 - 7.8 Vulcanizing and Retreading
 - 7.9 Wheel balancing and static balancing
- 8.0 Ignition System
 - 8.1 Introduction
 - 8.2 Study of wiring of Magnet Ignition , Battery Coil Ignition and Electronic Ignition System

- 9.0 Charging System
 - 9.1 Introduction
 - 9.2 Construction and working of charging dynamo(D.C.Generator)
 - 9.3 Working principle of cut-out
 - 9.4 Voltage regulators-current regulators-construction and working
- 10.0 Starting System
 - 10.1 State the construction and working of a self starter(D.C Motor)
 - 10.2 Working principle of bendix drive with a sketch
 - 10.3 Solenoid construction and working
- 11.0 Lighting, Horn and Wipers
 - 11.1 Introduction
 - 11.2 Working of Head lamp, side or parking light, tail or stop light, dash light, direction signal light
 - 11.3 Adjustments of head lights
 - 11.4 Working of Dipper, Dim light, Door light & Destination board light
 - 11.5 Horn circuit construction and working
 - 11.6 Working of wiper
- 12.0 Battery
 - 12.1 Introduction
 - 12.2 Parts of lead acid battery and its functions
 - 12.3 Understand the ampere hour and watt-hour efficiency of the battery
 - 12.4 Know the different methods of charging and trickle charging
 - 12.5 Know the different methods of testing of lead-acid battery for full charged and discharged condition

CHAPTER 1

CLUTCH

1.1: Necessity of clutch in Automobiles:

In Automobiles, the clutch is used to engage or disengage the engine with the transmission system. It enables the rotary motion of one shaft to be transmitted to the second shaft as and when required.

1.1.a: Requirements of clutch:

- a) Torque Transmission
- b) Gradual engagement
- c) Heat dissipation
- d) Dynamic balancing
- e) Vibration damping
- f) Size
- g) Free pedal play
- h) Ease of operation

The clutch should be able to transmit the maximum torque. It should take drive gradually. During clutch application, the heat generated by the friction of clutch surfaces should be dissipated. During high speeds the clutch should be balanced.

1.2: Types of clutches:

The following are the main types of clutches:

1. Friction clutches
2. Fluid fly wheel.

1.2.1 : Friction clutches:

The Torque transmitted by a friction clutch depends

upon the factors namely Coefficient of friction (μ), Axial pressure (w) and Mean effective Radius of contact surfaces(R).

$$\text{The Torque Transmitted (T) = } \mu w R.$$

Types of friction clutches:

- 1.2.1.a) cone clutch
- b) Single plate clutch
- c) Mutilate clutch
- d) Semi centrifugal clutch
- e) Centrifugal clutch.

1.2: CONSTRUCTION AND WORKING OF SINGLE PLATE CLUTCH:

It is the most common type of clutch used in motor vehicles. It consists of only one clutch plate , mounted on the spines of the clutch shaft. The fly wheel is mounted on the engine crane shaft and rotates witch it. The pressure plate is bolted to the fly wheel through clutch springs, and is free to slide on the clutch shaft when the clutch pedal is operated.

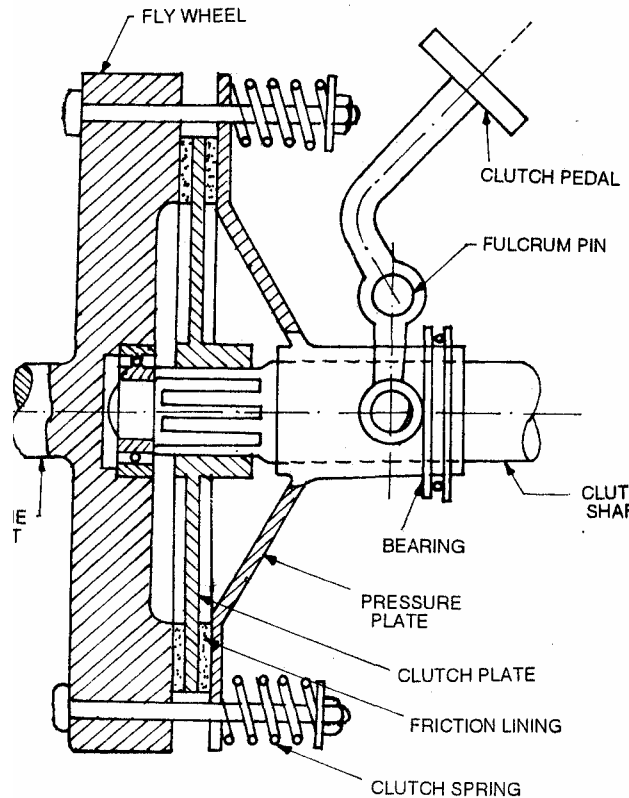

When the clutch is engaged, the clutch plate, having friction linings on its both sides, is gripped between the fly wheel and pressure plate.

Due to the friction between the flywheel, clutch plate and pressure plate revolves, the clutch shaft which is connected to the transmission system also revolves.

When the clutch pedal is pressed, the pressure plate moves back against the force of the springs, and the clutch plate becomes free between the fly wheel and pressure plate.

Thus, the flywheel remains rotating as long as the engine is running and the speed of the clutch shaft reduces slowly and finally it stops rotating. As soon as the clutch pedal is pressed, the clutch is said to be disengaged, otherwise it remains engaged due to the force of springs.

CONSTRUCTION AND WORKING OF MULTIPLATE CLUTCH:

Multi plate clutch consists of a number of clutch plates. As the number of clutch plates increased, the friction surfaces also increased. the increased number of friction surfaces obviously increases the capacity of the clutch to transmit torque. The plates are alternately fitted to the engine shaft and gear box shaft. one set of plates slides in grooves on the flywheel and the other set slides on spines on pressure plate hub. They are firmly pressed by strong coil springs and assembled in a drum. Each of the alternate plate slides in grooves on the flywheel and the other slides on spines on the pressure plate. Thus each alternate plate has inner and outer spines.

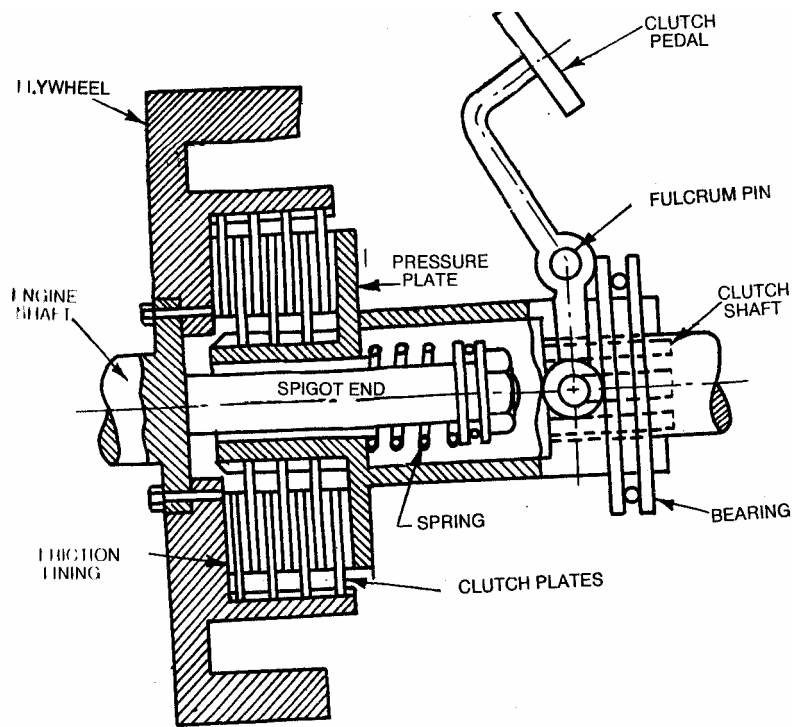
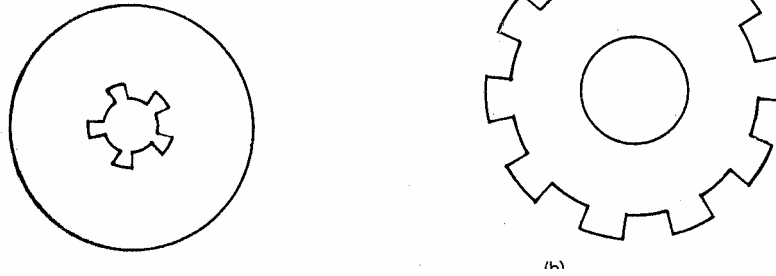

Fig. 22.6. Centrifugal clutch



These clutches are used in heavy commercial vehicles, racing cars and motor cycles for transmitting higher torque. Beside these clutches are used in scooters and motor cycles where space available is limited.

CENTRIFUGAL CLUTCH:

This type of clutch is operated automatically depending upon the engine speed. This means that the vehicle can be stopped in gear without stalling the engine. Similarly while starting, the driver can first select the gear, put the car into the gear and simply press the accelerator pedal. This makes driving operation very easy. This type of clutch is operated by the centrifugal force.

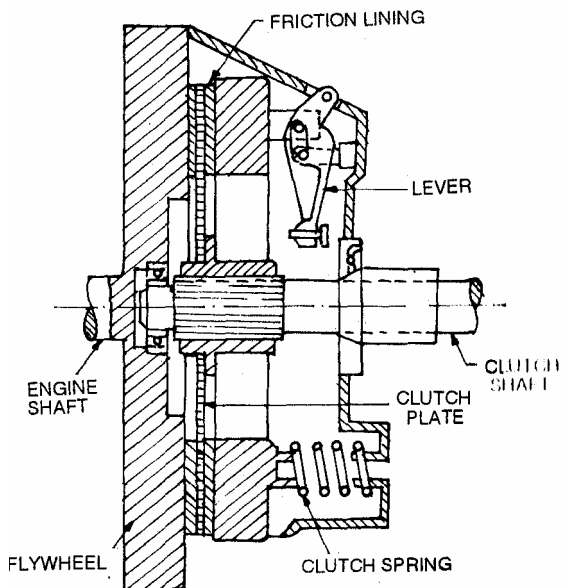

As per the figure given above, the centrifugal clutch is operated as given above.

As the speed increases, the weight 'A' flies these by operating

the bell crank lever 'B' which presses the plate 'C'. This force is transmitted to the plate 'D' by means of springs 'E'. the plate 'D', which contains frictional lining, is thus pressed against the flywheel 'F' there by engaging the clutch.

Spring 'G' serves to keep the clutch disengaged at low speed (at about 500 r.p.m). The stop 'H' limits the amount of centrifugal force.

Semi centrifugal clutch:

The semi centrifugal clutch uses the centrifugal force as well as spring force for keeping it in engaged position. The springs are designed to transmit the torque at normal speeds, while the centrifugal force assists in torque transmission at higher speeds.

It consists of three hinged and weighted levers and three clutch springs alternately arranged at equal spaces on the pressure plate,

At normal speeds, when the power transmission is low, the springs keep the clutch engaged, the weighted levers do not have any pressure on the pressure plate.

At high speeds, when the power transmission is high, the weights fly off and the levers also exert pressure on the plate keeping the clutch firmly engaged.

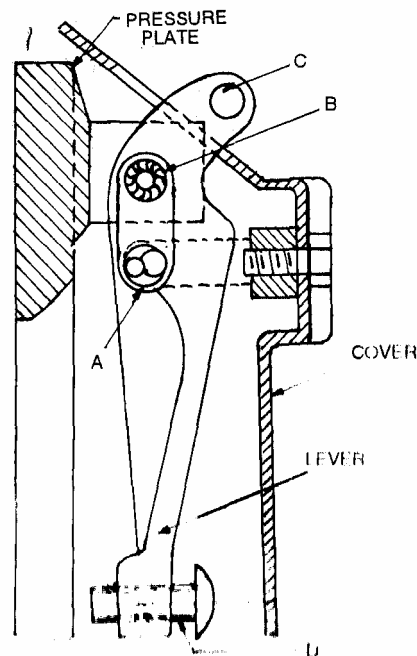

Clutch components:

The main components of a friction clutch are:

- 1) Clutch plate
- 2) Clutch facing
- 3) Pressure plate
- 4) Springs
- 5) Bearing

1) Clutch plate:

Clutch plate consists of steel plate with a splined central hub. Frictional facings are attached to the steel plate by rivets. The curved cushioning springs segments are attached rigidly to the center plate and the friction facings are riveted to these springs. The clutch plate is made in two parts i.e. a central hub assembly and outer facing ring assembly.

2) Clutch facing:

It is required to have good wearing properties and should have coefficient of friction and high resistance to heat.

The commonly used clutch facing materials are:

1. Leather
2. cork
3. fabric
4. asbestos
5. rebates and freedom.

3) Pressure plate:

High tensile gray iron is the most commonly used material for pressure plate. The pressure plate should be rigid enough to distort under pressure of clutch springs and also should have sufficient mass to absorb and conduct away the heat generated during disengagement.

4) Springs:

The clutch springs are made from oil tempered spring steel wire or silicon-chrome steel.

5) Bearing:

This is either a thrust ball bearing which is packed with grease for lubrication or graphite impregnated one which does not require lubrication.

CLUTCH ADJUSTMENT:

The only adjustment required for clutch is 'CLUTCH FREEPEDAL PLAY'.

Due to continuous use of clutch or due to wear of Release (throughout) bearing or due to habit of driver by keeping foot continuously on pedal, there will be wear in friction having lining of clutch.

To avoid this, there should be free pedal play in clutch pedal so that for certain time the clutch will not be operated even though the pedal moves.

This adjustment may be varied along with the wear of clutch lining or release bearing etc.

It can be done by changing the linkage between the pedal and release fork.

It's usual value is in between 30 and 35 mm.

CLUTCH TROUBLE SHOOTING:

The clutch may face most common troubles namely

1. Clutch slip
2. Clutch drag
3. Clutch judder
4. Clutch rattle
5. Knock

Some of which are etc. discussed here:

1. Clutch slip: Some times the clutch may slip while engagement. In this condition, it fails to transmit the engine torque completely. A large amount of heat generated which causes wearing and even burning of clutch plate.

The main reasons for clutch slipping are:

- a) Incorrect clutch linkage - Which is to be adjusted.
- b) Oil or grease on friction linings -To clean the lining.
- c) Weak or broken clutch springs -Replace the springs.
- d) Incorrectly adjusted release levers and fingers to be adjusted.

2. Clutch drag: Some times when the clutch is to be disengaged, it is not disengaged completely and it provides difficulty in changing the gears - which is called clutch drag. The following are the reasons and remedies.

- a) Excessive free pedal play - to be adjusted.
- b) Incorrect adjustment of release levers - should be adjusted.
- c) Pressure plate damaged - to be replaced.
- d) Clutch plate damaged - to be replaced.
- e) Clutch plate may be seized on clutch shaft splines - The splines may be cleaned and laminated.

3. Clutch judder: Some times as the clutch is engaged, a vibration or judder is produced instead of smooth gradual engagement.

The following are the reasons and remedies

- a) Loose or worn out clutch facings - clutch plate should be replaced.
- b) Loose rivets - Replace the clutch plate.
- c) Misalignment of pressure plate with flywheel - to be adjusted.
- d) Fly wheel may be loose on the crankshaft flange - to be tightened.
- e) Bent splined clutch shaft - may be straighten or to be changed.

FLUID FLYWHEEL:

The fluid fly wheel or hydraulic coupling has been used in cars employing automatic transmission.

It consists of two members, the driving and driven. The driving member is attached to the engine fly wheel and the driven member to the transmission shaft. The driven member is free to slide on splines on the transmission shaft.

HIGHLIGHTS:

- Clutch is an intermediate part between the engine and transmission which connects or disconnects between them.
- The main parts of single plate clutch are:
 - a) Fly wheel
 - b) Clutch plate
 - c) Pressure plate
 - d) Clutch springs
 - e) Fingers
 - f) Release bearing
 - g) Clutch pedal.
- When slowing down or stopping the vehicle, the engine should be disconnected with transmission which can be done by clutch otherwise the engine and transmission are connected continuously.

EXERCISE

A) SHORT ANSWER QUESTIONS:

- 1) What is the function of clutch?
- 2) How many types of friction clutches are there?
- 3) Mention any two causes for clutch slipping?
- 4) What is clutch free pedal play?

B) ESSAY TYPE QUESTIONS

- 1) Explain the construction and working of single plate c clutch with neat sketch.
- 2) Explain the construction and working of multi plate clutch with neat sketch.
- 3) Write short notes
 - a) Centrifugal clutch
 - b) Fluid fly wheel.
- 4) Briefly explain the Trouble shooting of the trouble 'CLUTCH DRAGGING'

CHAPTER 2

GEAR BOX

2.1 Necessity of gear box in Automobiles:

The purpose of transmission is to provide high torque at the time of starting, hill climbing, accelerating and pulling a load. The vehicle will have to face the resistances like wind resistance, gradient resistance and rolling resistance. The tractive effort of the vehicle can be available at various speeds.

The variation of total resistance to the vehicle motion is equal to the tractive effort of the vehicle with speed.

2.2 Types of gear boxes:

2.3 Types of gear boxes:

- a) Epicyclic or planetary gear box
- b) Progressive gear box
- c) Selective gear box

Again the selective gear boxes are classified into three types.

- 1) constant mesh gear box
- 2) selective mesh gear box
- 3) synchromesh gear box

2.2.1 EPICYCLIC GEAR BOX:

The epicyclic or sun and planet type gear box Uses no sliding logs or gears to engage but different gear speeds are obtained by merely tightening brake bands on the gear drums.

2.2.2 Progressive gear box:

In this gear box there will be a neutral position between

every two gears and is simple to operate.

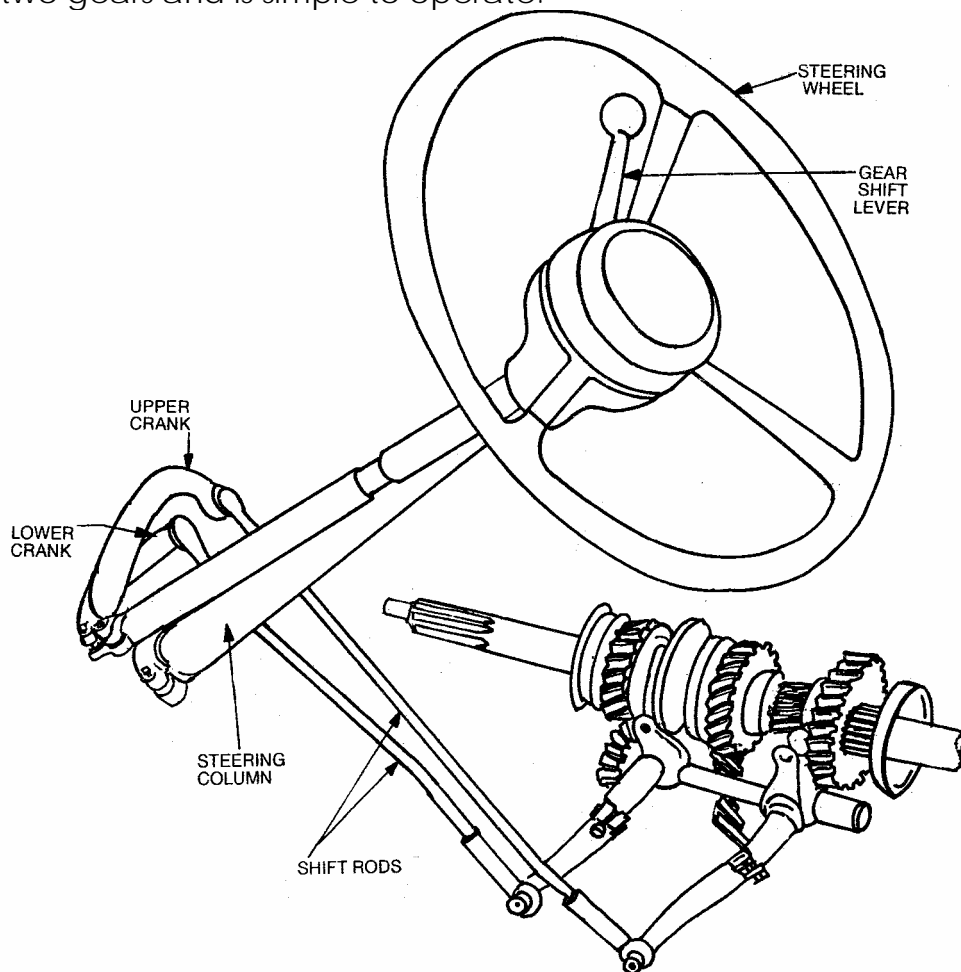

2.2.3 Sliding mesh gear box:

It is the simplest type of gear box. The clutch gear box. The clutch gear is rigidly fixed to the clutch shaft. It remains always connected to the drive gear of the lay shaft (counter shaft). The other gears also rigidly fixed to the counter shaft. A reverse idler gear is mounted on another shaft and always remains connected to the reverse gear of the counter shaft. The power is transmitted from the engine to the clutch shaft of gear box and will be transmitted to the main shaft through counter shaft. The required speed is obtained by shifting the gears in counter shaft by selective mechanism.

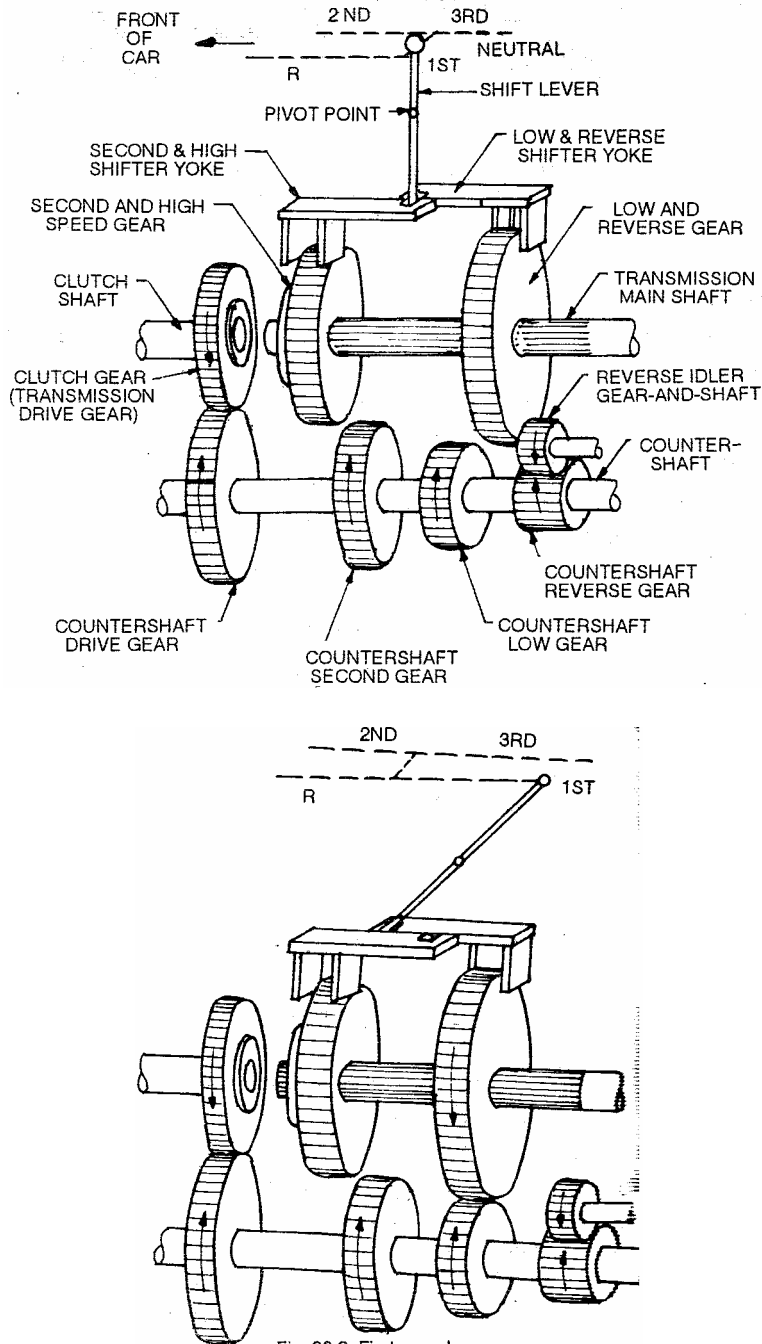

2.2.4: CONSTANT MESH GEAR BOX:

In this type of gear box, all the gears of main shaft are in constant mesh with the corresponding gears on the lay shaft.

Two dog clutches are provided to the main shaft one between the clutch gear and second gear and the other between the first and reverse gears. The dog clutches are provided which are free to slide on the main shaft.

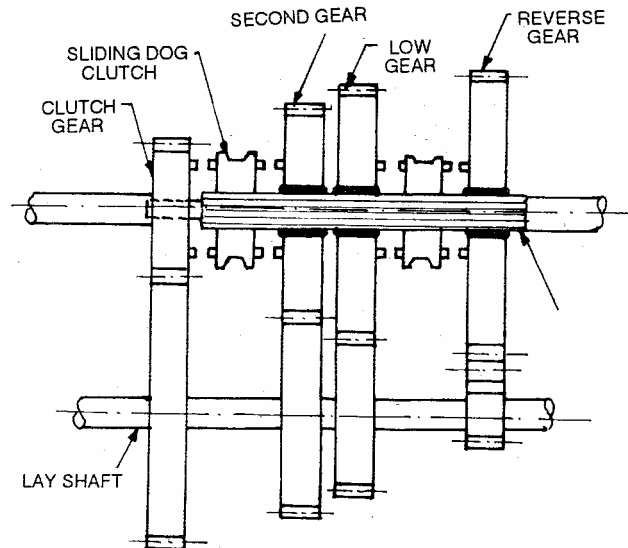

When the left dog clutch is slide to the left by means of selector mechanism, its teeth are engaged with those on the gear and then the top gear enclosed. However when slide to right makes contact with the second gear and second gear is obtained.

2.2.4. (a) Double de – clutching:

In constant mesh gear box, for smooth engagement of dog clutches it is necessary that the speed of main shaft and sliding dog clutch must be equal. To obtain lower gear, the speeds of the clutch shaft, lay shaft and main shaft must be increased. This is done by double declutching. The clutch is disengaged and the gear is brought to neutral. Then the clutch is engaged and accelerator pedal pressed to increase the speed of the main shaft gears. Again the clutch is disengaged and the gear moved to the required lower gear and the clutch is again engaged.

As the clutch is disengaged twice, it is called double declutching.

2.2.5: SYNCHROMESH GEARBOX:

In modern cars, helical gears and synchromesh devices are used in gear boxes to synchronize the rotation of gears that are about to be meshed. This gear box is provided with synchromesh devices by which two gears to be engaged are first brought into frictional contact which they are engaged smoothly.

When the gear lever is moved, the synchronizer cone meets with a similar cone on the pinion. Due to the friction, the rotating pinion is made to rotate at the same speed as the synchromesh unit.

To give a positive drive further movement of the gear lever enables the coupling to override several spring loaded balls and the coupling

engages with the dog on the ride of the pinion. Since both pinion and synchronmesh unit are moving at the same speed, this engagement is done without noise or damage to the dogs.

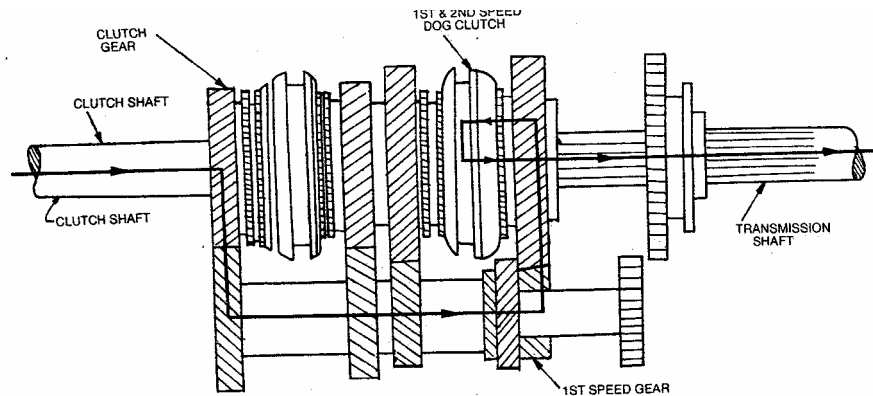

2.3: Constructional details of gear box:

The gear box consists of the following main parts

1. Gear box housing
2. Primary shaft (or) Clutch shaft
3. Lay Shaft (or) Counter shaft
4. Main shaft
5. Selector Mechanism
6. Reverse gear.

Gear box housing is used to house all the gear shafts along with gears. The Lubricating oil is poured in the housing to lubricate the gears and shafts.

Primary Shaft is the main drive gear which is connected to the clutch at its front end. Its rear end is having gear teeth and is connected to the counter shaft.

Counter Shaft is another Shaft having gears of different speeds which will connect to the corresponding gears in main shaft by means of selecting forks in the selector mechanism.

Main Shaft is also having gears of different speeds. From this shaft only the transmission will be done to the propeller shaft through universal joint.

Selector Mechanism: It consists of gear lever, gear box top cover, spring leaded balls, selector sleeves and selector forks.

Reverse gear: The reverse gear is housed in the gear box separately. When selected only, it also will be engaged with the same speed as the First gear.

HIGHLIGHTS:

- The Vehicle has to overcome the resistance like Wind resistance, rolling resistance and gradient resistance.
- The gear box has to give attractive effort to overcome the resistance by increasing the efficiency of the vehicle.
- There are three types of selective gear boxes constant mesh, sliding mesh and synchromesh gear boxes.
- The gear box is having the components take Housing, Primary shaft, lay shaft, Main shaft, reverse gear and selector mechanism.

EXERCISE:

(A) Short Answer Questions:

1.

CHAPTER 3

UNIVERSAL JOINTS AND PROPELLERSHAFT

3.1.1: PROPELLER SHAFT:

This is the shaft which transmits the drive from the gearbox to the bevel pinion or worm of final drive which is attached to the differential. It is a driving shaft that connects the transmission to the differential.

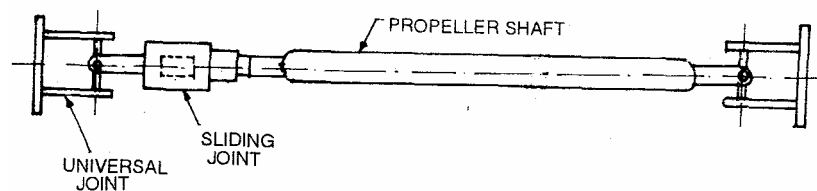

3.1.2: UNIVERSAL JOINTS:

Universal joints are used to connect two shafts at an angle to transmit torque. The main shaft of transmission, propeller shaft and differential are not in one line and hence the connection between them is made by universal joints.

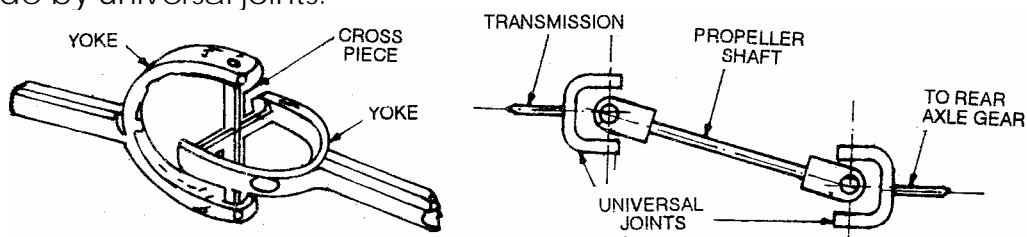

3.2. TYPES OF UNIVERSAL JOINTS:

The Universal joints are classified into different types. Some of them are

- Cross type (or) Spender and two yoke
- Ball and trunion type
- Constant Velocity type

Cross type Universal Joint consists of cross piece or spider and two yokes. There are four needle bearings, one for each trunion of the spider.

The Ball and Trunion type Universal joint consists of a ball head fastened to the end of the propeller shaft through which a pin is pressed.

The constant velocity Universal joint consists of two individual Universal Joints linked by Ball and socket. The Ball and sockets split the end of two propeller shafts between the two Universal joints. This type of joint permits uniform motion.

Slip joint: Slip joint is used to adjust the length of the propeller shaft as and when demanded by the rear axle movements.

When the rear spring compresses, the differential rises up and the propeller shaft is shortened. When the springs again expand, the differential returns to its original position and the propeller shaft gets its original length. Therefore a slip joint or sliding joint is used to compensate for the change in length of the propeller shaft.

(Fig 22.7 in R B Gupta)

Types of Drives:

1. HOTCHKISS DRIVE
2. TORQUE TUBE DRIVE

HOTCH KISS DRIVE:

HOTCH KISS DRIVE consists of propeller shaft, two universal joints and a slip joint. The leaf springs besides taking weight of the body, also take the torque reaction, driving thrust and side thrust. The front end of the leaf spring is fixed rigidly on the frame, while the rear end is supported in a shackle. The driving thrust is transmitted to the frame by the front half of the springs. Due to the torque reaction the spring deflects. Thus torque reaction is taken up by the springs. When the springs deflect, the bevel pinion shaft also changes its position. If there is only one universal joint, it will bend. To avoid this, another universal joint is used.

Again when the rear axle moves up and down, it has to move in a circle. During this movement of rear axle, the length of propeller shaft has to vary which is done by slip joint (sliding joint).

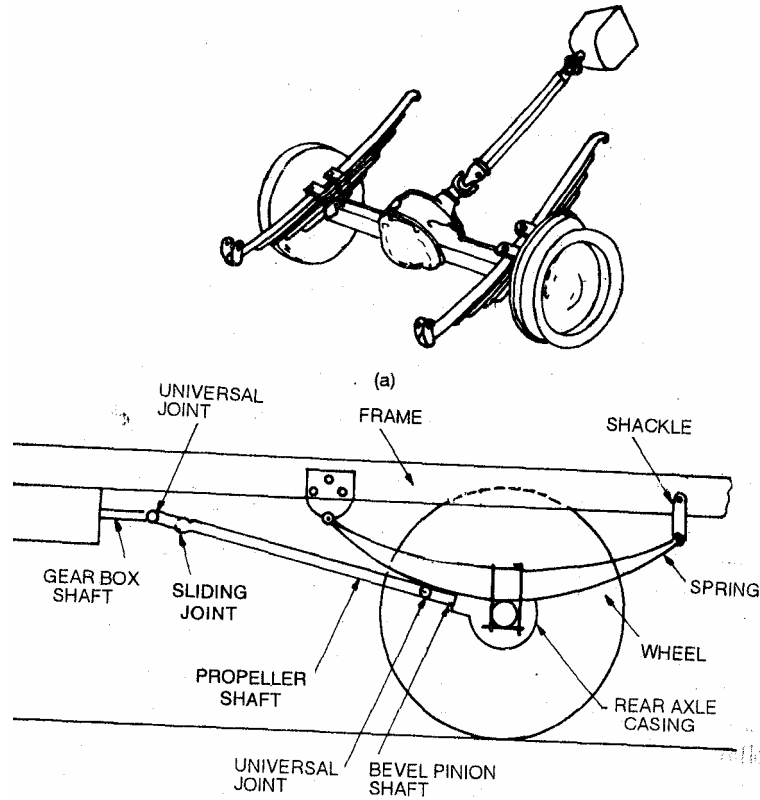

TORQUE TUBE DRIVE

In Torque tube drive, the propeller shaft is enclosed in a hollow tube. The tube is rigidly bolted to the differential housing at one end and is fastened at the other end to the transmission through a flexible joint. In this drive the springs take only the side thrust besides supporting weight of the body. The tube incorporates bearing which support the propeller shaft. Only one universal joint is necessary in this drive. It is usually placed between the transmission and the propeller shaft. No sliding joint is necessary.

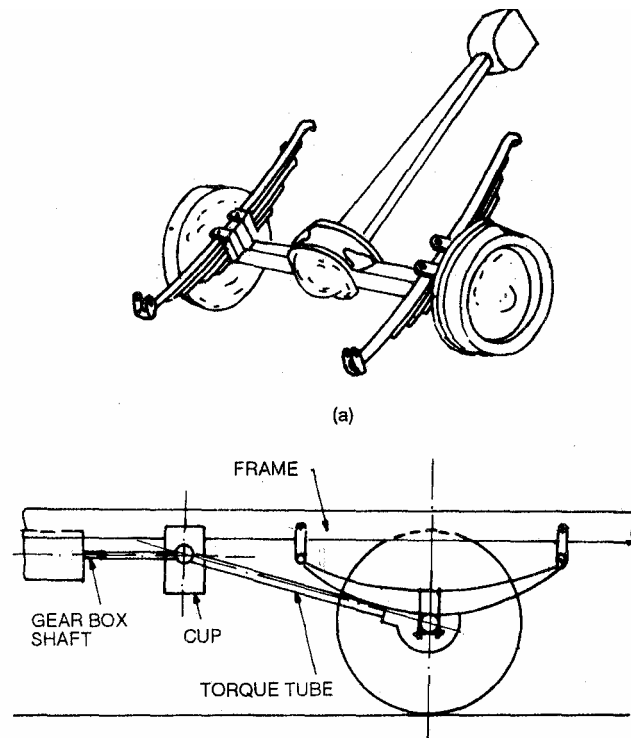

HIGHLIGHTS:

- Propeller shaft is the driving shaft that connects the transmission to the differential.
- Universal joints are connected between gearbox and propeller shaft and sometimes between propeller shaft and differential.
- U- Joint is used where two shafts are connected at an angle to transmit torque.
- The slip joint compensates for differences in length of the propeller shaft caused by changes in its angularity as the axle moves up and down with the springs.

: EXERCISE:

(A) SHORT ANSWER QUESTIONS:

CHAPTER 4

DIFFERENTIAL UNIT

4.1: Necessity of Differential:

When the vehicle is taking a turn, the outer wheels will have to travel greater distance as compared to the inner wheels in the same time. If therefore, the vehicle has as a solid rear axle only, there will be tendency for the wheels to skid. Hence if the wheel skidding is to be avoided, some mechanism should be provided in the drive axle.

The Mechanism which reduces the speed of inner wheels and increases the speed of outer wheels when taking turn and while running straight it keeps the speeds of all the wheels same in known as differential mechanism.

4.2 : Construction and working of Differential:

The following are the main parts of differential.

1. Differential Housing
2. Crown wheel (or) Crown pinion
3. Sun pinions or sun gears
4. Star pinions or star gears
5. Axle Half shafts
6. Final drive.

The Sun gears are mounted on the inner end of each half shaft of the drive axle.

The Crown wheel is attached in the differential cage to which the power is transmitted from gear box through propeller shaft and final drive bevel pinion. When the differential unit rotates, both the sun gears rotate and thus both wheels turn which are attached to the half shafts. Suppose one wheel is held stationary, the gears of star pinions carry rotary motion to the outer axle causing it to rotate.

Therefore, when one rear wheel runs more rapidly than the other, While the car taking a turn, the star gears spin on the shaft transmitting more rotary motion to the outer wheel. This causes faster rotating of outer wheel than the inner.

4.3.1: Differential Lock:

The torque transmitted by the bevel gear differential to each of the rear wheels remains equal even when they are rotating at different speeds. Due to this reason if one wheel is on a slippery surface, mud, loose dirt or sand the wheel on the solid ground will not be driven while the other spins around idly. When the differential lock is applied, the differential action is stopped and the whole torque is then applied to the wheel which is gripping on the road.

4.3.2 Self Locking Differential:

A self locking differential consists of two clutches, one on each side, to lock the side gears and axles to the differential cage, when the differential action is not desired. The mechanism consists of four differential pinion gears mounted on two cross shafts at right angles to each other.

When the differential cage is driven by the rear axle gears, the turning resistance causes the cross shafts to move up the ramps and push the shafts apart. This action forces the pinions on each shaft to bear against the side gear rings in order to apply the clutch which locks both axle shafts and force them to turn at the same speed.

CHAPTER 5

FRONT AND REAR AXLES

FRONT AXLE:

The front axle is used to carry the weight of the front part of the vehicle as well as to facilitate steering and to absorb shocks due to road surface variations. It is usually a steel drop forging having 0.4% Carbon steel or 1-3% of nickel steel. It is made of I-section in the center portion while the ends are made either circular or elliptical. Its different components are

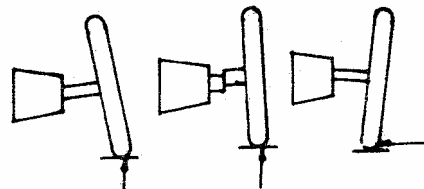

- a) The axle beam,
- b) Stub axle
- c) Swivel pin and
- d) Track Rod.

Usually the front axle is dead axle which do not transmit power . It is only supporting axle. In four wheel drive vehicles only, the front axle is live axle.

REAR AXLE: Almost all the vehicles have live axles as rear axles. The Axle housing completely remain stationary, do not move with the wheels. The rear axle should carry the following loads.

1. The total rear weight of the vehicle causing both bending and shearing actions.
2. Side thrust on the wheels when cornering, which imposes bending load and an end thrust or a pull.
3. Driving torque.

Stub Axle: The front wheels are mounted on stub axles, which are connected to the front axle by means of king pins. The stub axles are forgings of 3% nickel steels and alloy steels containing chromium and molybdenum. The stub axle turns on the king pin by a taper cotter pin.

Types of Stub Axles:

1. ELLIOT TYPE
2. REVERSED ELLIOT TYPE
3. LAMOINE TYPE
4. REVERSED LAMOINE TYPE
5. BALL JOINT CONNECTION TYPE

In ELLIOT TYPE and in REVERSED ELLIOT TYPE the axle beam and the stub Axle are connected side by side where as in LAMOINE TYPE and REVERSED LAMOINE TYPE the axle beam and stub axles are placed over each other.

Among all these types, the REVERSED ELLIOT TYPE Stub axle is commonly used. However in modern cars, the king pin is replaced by ball joints. The stub axle is connected to the suspension members of the vehicle by means of ball joints.

(Figs 20.3 in page 130 of A E (Vol2) K M Gupta)

TYPES OF REAR AXLE:

The Rear Axle half shafts have to with stand the loads like

1. Vehicle weight causing both bending and shearing actions.
2. Side thrust on the axle shaft.
3. Driving torque.

The axle shaft has to take driving torque. Some other loads also taken by axle Shafts. According to load taking position the rear axles are classified into three types.

1. SEMI FLOATING AXLE
2. FULL FLATING AXLE
3. THREE QUARTER FLOATING AXLE

SEMI FLATING AXLE: In this type of axle, the axle shaft has to take all the Loads. The vehicle load is transmitted to each of the half shafts through the casing and bearing. Since the axle shafts have support all loads, they have to be of larger diameter for same torque output.

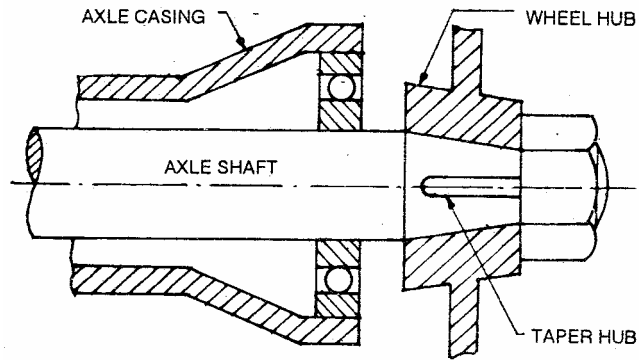

FULL FLOATING AXLE:

In full floating axle only driving torque is taken by the axle shaft. This axle is very robust one and is used for heavy vehicles. The weight of the vehicle and the end thrust are not carried by them, the weight being completely supported by the wheels and axle casing. As the axle shafts carry only driving torque, their removal does not effect wheels. Thus the axle shafts can be taken out or replaced without jacking up the vehicle.

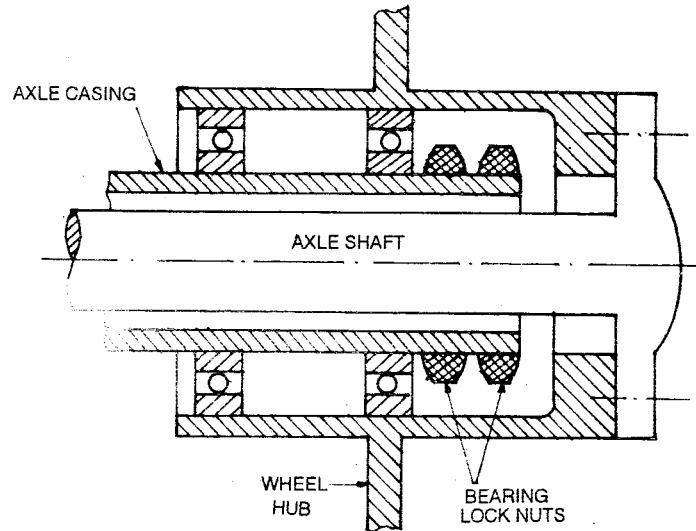

THREE QUARTER FLATING AXLE

In this axles, bearing is located between the axle casing and the hub. The Axle shafts do not have to withstand any shearing or bending actions due to the weight of the vehicle. It has to take the end loads and the driving torque.

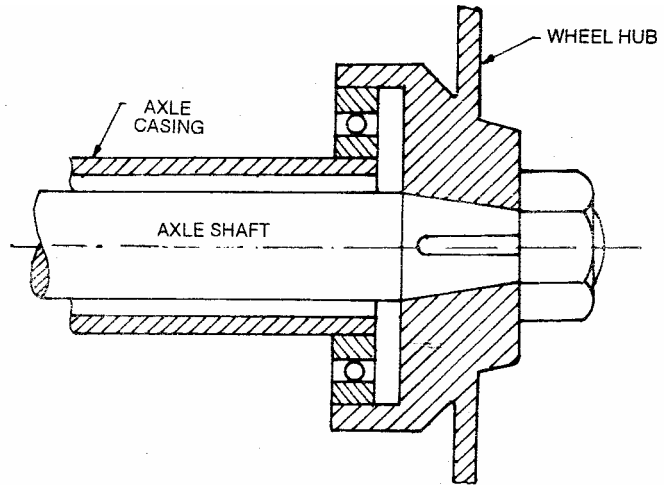

CHAPTER 6

SUSPENSION SYSTEM

FUNCTIONS OF SUSPENSION SYSTEM

In Automobiles

1. To prevent road shocks from being transmitted to the vehicle frame and its Parts.
2. To preserve the stability of the vehicle in pitching or rolling while in motion.
3. To safeguard the passengers and cargo from shocks.
4. To provide good gripping on road while driving, cornering and Braking.
5. To maintain proper steering geometry.

Front End Suspension: In order to permit the front wheels to swing to one side or the other for steering, each wheel is supported on a spindle which is part of a steering knuckle.

The Front end suspension are of two types

1. Rigid front axle suspension
2. Independent front suspension

Rigid front Axle suspension: In this type of suspension, the front wheel hubs rotate on antifriction bearings on steering spindles which are attached to the steering knuckles. In this suspension either two longitudinal leaf springs or transverse springs usually along with shock absorbers are used.

Independent front Suspension:

In independent front suspension, each front wheel is independently supported by coil spring torsion bar or leaf spring along with shock absorber.

There are three types of coil spring arrangements. In the first type, the coil spring is located between the upper and lower control arms. The lower control arm has one point attachment to the frame.

In the second type, the coil spring is located between the upper and lower control arms. The lower control arms has two point attachment to the frame.

In the third type the coil spring is between the upper control arm and spring tower in the front end of the body.

TYPES OF SUSPENSION SPRINGS:

1. Steel Springs
 - a) Leaf Spring
 - b) Tapered leaf spring
 - c) Coil spring
 - d) Torsion Bar
2. Rubber Springs
 - a) Compression Spring
 - b) Compression shear spring
 - c) Steel reinforced spring
 - d) Progressive spring
 - e) Face shear spring
 - f) Torsional shear spring
3. Plastic Spring

LEAF SPRING:

Leaf spring consists of a number of leaves called blades. Every successive blade is shorter than the main leaf. The lengthiest blade in main leaf (Master leaf) which has eyes on its both ends. All the blades are clamped together. The spring is supported on the axle. One end of the spring is mounted on the frame with a simple pin, while on the other end, connection is made with a shackle. When the vehicle comes across a projection on the road surface the wheel moves up deflecting the spring. This changes the length between the eyes of the spring. If both ends are fixed, the spring will not be able to accommodate the change of length. Therefore the shackle is provided to hinge the Leaf spring unit. Generally the leaf springs used at rear part kept longer than front leaf spring unit. The leaver of leaf spring require lubrication at periodic intervals except in some vehicles like Hindustan Ambassador Cars.

(Fig 214 Page of K P Sing)

HELPER SPRINGS:

Helper springs are provided on many commercial vehicles in addition to main leaf springs. These helper springs will only come into operation when the load is increased. These are used for rear suspension only.

(Fig 219 Page of K P sing)

SHACKLE: The front end of leaf spring is fixed with the bracket of the frame while its rear end is connected with the shackle and the shackle is connected to the frame. The shackle is hinged with the frame. It can swing forward or backward.

COIL SPRING: The coil springs are mainly used with independent suspension system. The energy stored per unit volume is almost double in the case of coil springs than leaf springs. The spring takes the shear as well as bending stresses but cannot take torque reaction and side thrust.

SHOCK ABSORBERS:

The shock absorber is a damping device and is used to damp the vibrations of the spring. It prevents excessive flexing of the spring and enhances riding comfort. It is used along with leaf spring or coil spring. The shock absorber controls the vibration of spring by damping it down.

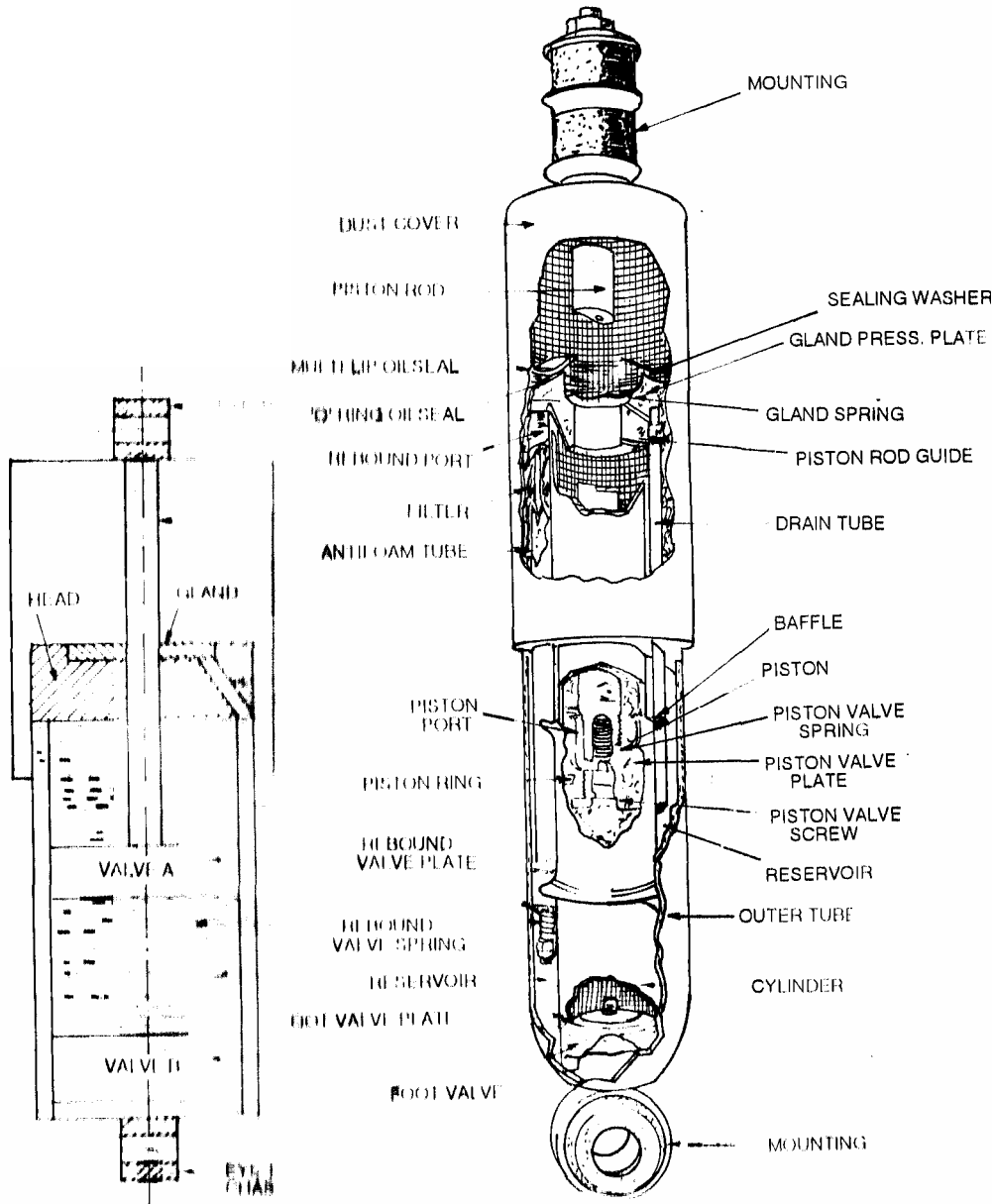

Construction:

It is upper eye is connected to the axle and the lower eye to the chassis frame. A two way valve 'A' is attached to the rod 'G'. Another two way Valve 'B' is attached to the lower end of cylinder 'C'. The fluid is in the space above and below the valve 'A' and also in the space between the cylinder 'C' and tube 'D'.

WORKING: When the Vehicle comes across a bump, the lower eye 'E' moves up. The fluid passes from the lower side of the valve 'A' to its upper side. The fluid exerts pressure on valve 'B' as the space above the

valve 'A' is less. This pressure of the fluid through the valve openings provides the damping force. Similarly when the lower eye 'E' moves down, the fluid passes from the upper side of the valve 'A' to the lower side and also from the lower side of the valve B to its upper side.

CHAPTER 7 WHEELS AND TYRES

FUNTION OF WHEELS & TYRES

The Wheel along with the tyre has to take the vehicle load, provide a cushioning effect and cope with the steering control. The wheel must fulfill the following requirements.

1. It must be strong enough .
2. It should be balanced both statically as well as dynamically.
3. It should be lightest possible so that the unsprung weight is least.

TYPES OF WHEELS:

The Wheels are usually of the following types

1. DISC Wheels
2. Wire Wheels (Spoked Wheels)
3. Split Wheels
4. Heavy Vehicle wheels

1. DISC WHEEL : This type of wheel consists of a steel rim and a pressed steel disc. The rim is a rolled section, sometimes riveted but usually welded to the flange of the disc. The wheel assembly is bolted to the brake drum. There is a hole in the rim to accommodate the valve of tube. This type of wheel is most commonly used in Heavy motor vehicles.

2. WIRE WHEELS : This type of wheel consists of a separate hub connected to the rim with a number of wire spokes. The headed inner ends of spokes fit into the rim holes and tightened with tubular nuts. All the spokes are centred at the hub.

3. SPLIT WHEEL: The split wheel is made in the form of two dishes which fit back to back and are clamped by a separate outer ring of studs and nuts.

4. HEAVY VEHICLE WHEELS : These are of the same type of disc wheels but thicker plates are used for making the rim.

RIMS:

The Wheel along with the tyre has to take the vehicle load, provide a cushioning effect and cope with the steering control. The wheel must fulfill the following requirements.

4. It must be strong enough .
5. It should be balanced both statically as well as dynamically.
6. It should be lightest possible so that the unsprung weight is least.

TYPES OF WHEELS:

The Wheels are usually of the following types

5. DISC Wheels
6. Wire Wheels (Spoked Wheels)
7. Split Wheels
8. Heavy Vehicle wheels

1. DISC WHEEL : This type of wheel consists of a steel rim and a pressed steel disc. The rim is a rolled section, sometimes riveted but usually welded to the flange of the disc. The wheel assembly is bolted to the brake drum. There is a hole in the rim to accommodate the valve of tube. This type of wheel is most commonly used in Heavy motor vehicles.

2. WIRE WHEELS : This type of wheel consists of a separate hub connected to the rim with a number of wire spokes. The headed inner ends of spokes fit into the rim holes and tightened with tubular nuts. All the spokes centred at the hub.

3 SPLIT WHEEL: The split wheel is made in the form of two dishes which fit back to back and are clamped by a separate outer ring of studs and nuts.

4 HEAVY VEHICLE WHEELS : These are of the same type of disc wheels but thicker plates are used for making the rim.

RIMS:

The outer circular portion of the wheel on which the tyre is in general .

1. DROP CENTRE TYPE
2. FLAT BASE TYPE

When the center portion of the rim is rolled to a smaller diameter, it is known as Drop Centre rim.

The Flat base rim has its center portion flat. One side of the rim is removable so that the tyre can be installed or removed without stretching the bead.

TYRES:

The tyre is mounted on the wheel rim. It has to carry the vehicle load and provide a cushioning effect absorbing flexing actions. It must produce a minimum noise while running. It should have good grip while accelerating and braking the vehicle on both dry and wet roads. It should resist the tendency of over steer while cornering.

TYPES OF TYRE:

The tyre are mainly two types.

1. TUBED TYRE: It is a traditional tyre which encloses a tube in which air is forced to a high pressure as a cushioning medium. The outer portion of the tyre which roll on the road is made of synthetic rubber and is called TREAD. The beads of tyre edges act as strong shoulders which fit to the wheel rim.

2. TUBE LESS TYRE: Tube less tyre does not enclosed the tube . The air under pressure is filled in the tyre itself. A Non -return valve is fitted to the rim through which the air is forced into the tyre.

TYRE CONSTRUCTION:

The tyre construction is divided into two classes.

1. Cross ply tyre construction
2. Radial ply tyre construction

In the cross ply tyre construction the alternate layers of cords run in opposite diagonal directions. These tyres have better wear and road holding characteristics.

In Radial ply tyre construction , the cords run radially from bead to bead.

TYRE CONSTITUENTS: The basic constituents of a tyre are as follows:

1. Rubber – Natural or Synthetic compounded with Large number of chemical to ensure necessary characteristics.

2. Nylon or Rayon cord fabric for the tyre body.
3. Steel for high tensile steel bead wires which is denoted as PLYRATING.

TYRE PROPERTIES:

A tyre must have following desired properties:

1. Non-Skidding : The tyre should not skid or slip on the road surface. It should have good grip.
2. Uniform wear : The tyre must get wear uniformly over its outer circumference
3. Load carrying the tyre should be able to carry the vehicle load and also alternate stresses during each revolution.
4. Cushioning : The tyre should be able to absorb vibrations set up by the road surfaces and then provide cushioning effect.
5. Power consumption : While rolling on the road, tyre should consume least power developed by the engine.
6. Noise: The tyre should create minimum noise while running on the road.
7. Balancing: The tyre should be balanced statically as well as dynamically.

TUBE:

The tube which is made of rubber moulding to conform the inner shape of tyre. Air is forced into the tube under pressure through a Non return valve which projects outside through a hole in the rim.

CAUSES OF TYRE WEAR:

1. Incorrect inflation of Air
2. Incorrect caster Angle, camber Angle or Toe-in
3. Excessive braking or violent acceleration
4. Worn out steering mechanism
5. Worn out king pins
6. Overloading
7. Incorrect tyre rotation
8. Uneven and wrong loading

TYRE SPECIFICATIONS:

W-Width of tyre in inches (or) Millimeters

(It is also the internal width of rim to which tyre is fitted)

(Generally inches are used for cross ply rating and millimeters for radial ply tyres)

D- Diameter of the rim (or) Inner diameter of rim in Inches or Millimeters.

(Taken at the point of contact of tyre and rim)

Some examples of tyre sizes mentioned hereunder

- (i) 145 SR-13- signifies that the tyre has W=145 mm, D=13 inches and is ment for speed up to 170kmph. Here 'SR' denotes Speed Rating

SR – upto 170 Kmph

HR- upto 210 Kmph

VR – above 210Kmph

- (ii) 9.00 – 20-12 means a tyre of 9 inches with, 20 inches diameter and 12 ply rating.

TYRE ROATION:

To maintain the Uniformity in tyre wear in al the wheels of the vehicle, the tyre should be rotated usually for every 8000 to 12000 Kms. The rotation increases the tyre life also . Some examples of tyre rotation are given here under.

Fig 23.11 in page 560 (rbg)

8.69in page 385(K P S)

8.70in page 385(K P S)

TYRE RETREADING:

It is a proess of reconditioning of an old tyre and giving it a new life again. The part of the tyre which rolls on the road (Face of the tyre) can be replaced with new one unutil the casing of tyre is in good condition.

Tyre Re treading is done by a special tread rubber available in market.

VULCANIZING OF TUBE:

Basically a tube is made of natural rubber whose monomer is isoprene. It has two double bonds out of which one is used in chain formation and other in producing on elastomer. The ealstomer is stronger than rubber and is formed during tube vulcanization. The raw rubber is heated in the proesence of sulpher under a specified pressure. Sulpher

forms covalent bonds with carbon and cross links the chains. This process is called vulcanization.

WHEEL BALANCING:

The balancing of tyred wheel is essentially required to avoid front wheel wobble which effects steering and increase tyre wear. Therefore it is necessary to inspect the wheel centering before wheel balancing. The tyre must be removed to straighten the wheel rim. Turn the wheel rim on its axis and check the wheel inside flanges for run out in excess of 1.5 mm.

STATIC BALANCE OF FRONT WHEELS:

It can be made with the wheels installed on the vehicle using electronic balances. The process should be as follows.

1. Lift the front wheels on jack and make sure that they are free to turn freely.
2. Arrange the spinner of balance equipment with its pulley to touch the tyre tread
3. Positio the pickup magnet in contact with the front wheel as close as possible.
4. Balance the wheel properly

DYNAMIC BALANCE OF FRONT WHEELS.

1. TURN THE WHEELS OUT Approximately one half of their steering geometry.
2. Position the pickup the magnet in contact with the external front end of the brake housing flange t the wheel rotation Axis.

SATIC BALANCE OF READ WHEELS:

1. Place the jack under the Read Axle housing
2. Position the pickup magnet in contact with the lower axle end as close to the wheel as possible.
3. Ten balance the wheel.

PART II : AUTO ELECTIRCAL SYSTEMS:

- The outer circular portion of the wheel on which the tyre in general .
3. DROP CENTRE TYPE
 4. FLAT BASE TYPE

When the center portion of the rim is rolled to a smaller diameter, it is known as Drop Centre rim.

The Flat base rim has its center portion flat. One side of the rim is removable so that the tyre can be installed or removed without stretching the bead.

TYRES:

The tyre is mounted on the wheel rim. It has to carry the vehicle load and provide a cushioning effect absorbing flexing actions. It must produce a minimum noise while running. It should have good grip while accelerating and braking the vehicle on both dry and wet roads. It should resist the tendency of over steer while cornering.

TYPES OF TYRE:

The tyre are mainly two types.

1. TUBED TYRE: It is a traditional tyre which encloses a tube in which air is forced to a high pressure as a cushioning medium. The outer portion of the tyre which roll on the road is made of synthetic rubber and is called TREAD. The beads of tyre edges act as strong shoulders which fit to the wheel rim.

2. TUBE LESS TYRE: Tube less tyre does not enclosed the tube . The air under pressure is filled in the tyre itself. A Non -return valve is fitted to the rim through which the air is forced into the tyre.

TYRE CONSTRUCTION:

The tyre construction is divided into two classes.

3. Cross ply tyre construction
4. Radia ply tyre construction

In the cross ply tyre construction the alternate layers of cords run in opposite diagonal directions. These tyres have better wear and road holding characteristics.

In Radial ply tyre construction , the cords run radially from bead to bead.

TYRE CONSTITUENTS: The basic constituents of a tyre are as follows:

4. Rubber – Natural or Synthatic compounded with Large number of chemical to ensure necessary characteristics.
5. Nylon or Rayon cord fabric for the tyre body.
6. Steel for high tensik steel bead wires which is denoted as PLYRATING.

TYRE PROPERTIES:

A tyre must have following desired properties:

8. Non-Skidding : The tyre should not skid or slip on the road surface. It should have good grip.
9. Uniform wear : The tyre must get wear uniformly over it is outer circumference
10. Load carrying the tyre should be able to carry the vehicle load and also alternate stresses during each revolution.
11. Cushioning : The tyre should be able to absorb vibrations setup by the road surfaces and then provide cushioning effect.
12. Power consumption : While rolling on the road, tyre should consume least power developed by the engine.
13. Noise: The tyre should create minimum noise while running on the road.
14. Balancing: The tyre should be balanced statically as well as dynamically.

TUBE:

The tube which is made of rubber moulding to conform the inner shape of tyre. Air is forced into the tube under pressure through a Non return valve which projects outside through a hole in the rim.

CAUSES OF TYRE WEAR:

9. Incorrect inflation of Air
10. Incorrect coastor Angle, camber Angle or Toe-in
11. Excessive braking or violent acceleration
12. Worn out steering mechanism
13. Worn out king pins
14. Overloading
15. Incorrect tyre rotation
16. Uneven and wrong loading

TYRE SPECIFICATIONS:

W-Width of tyre in inches (or) Millimeters

(It is also the internal width of rim to which tyre is fitted)

(Generally inches are used for cross ply rating and millimeters for radial ply tyres)

D- Diameter of the rim (or) Inner diameter of rim in Inches or Millimeters.
(Taken at the point of contact of tyre and rim)

Some examples of tyre sizes mentioned hereunder

- (iii) 145 SR-13- signifies that the tyre has W=145 mm, D=13 inches and is ment for speed up to 170kmph. Here 'SR' denotes Speed Rating

SR – upto 170 Kmph

HR- upto 210 Kmph

VR – above 210Kmph

- (iv) 9.00 – 20-12 means a tyre of 9 inches with, 20 inches diameter and 12 ply rating.

TYRE ROATION:

To maintain the Uniformity in tyre wear in al the wheels of the vehicle, the tyre should be rotated usually for every 8000 to 12000 Kms. The rotation increases the tyre life also . Some examples of tyre rotation are given here under.

Fig 23.11 in page 560 (rbg)

16.69 in page 385(K P S)

16.70 in page 385(K P S)

TYRE RETREADING:

It is a proess of reconditioning of an old tyre and giving it a new life again. The part of the tyre which rolls on the road (Face of the tyre) can be replaced with new one unitil the casing of tyre is in good condition.

Tyre Re treading is done by a special tread rubber available in market.

VULCANIZING OF TUBE:

Basically a tube is made of natural rubber whose monomer is isoprene. It has two double bonds out of which one is used in chain formation and other in producing an elastomer. The elastomer is stronger than rubber and is formed during tube vulcanization. The raw rubber is heated in the presence of sulphur under a specified pressure. Sulphur forms covalent bonds with carbon and cross links the chains. This process is called vulcanization.

WHEEL BALANCING:

The balancing of a tyre wheel is essentially required to avoid front wheel wobble which affects steering and increases tyre wear. Therefore it is necessary to inspect the wheel centering before wheel balancing. The tyre must be removed to straighten the wheel rim. Turn the wheel rim on its axis and check the wheel inside flanges for run out in excess of 1.5 mm.

STATIC BALANCE OF FRONT WHEELS:

It can be made with the wheels installed on the vehicle using electronic balances. The process should be as follows.

5. Lift the front wheels on jack and make sure that they are free to turn freely.
6. Arrange the spinner of balance equipment with its pulley to touch the tyre tread
7. Position the pickup magnet in contact with the front wheel as close as possible.
8. Balance the wheel properly

DYNAMIC BALANCE OF FRONT WHEELS.

3. TURN THE WHEELS OUT Approximately one half of their steering geometry.
4. Position the pickup magnet in contact with the external front end of the brake housing flange to the wheel rotation Axis.

STATIC BALANCE OF REAR WHEELS:

4. Place the jack under the Rear Axle housing
5. Position the pickup magnet in contact with the lower axle end as close to the wheel as possible.
6. Then balance the wheel.

PART II : AUTO ELECTRICAL SYSTEMS:

CHAPTER 8

IGNITION SYSTEM

INTRODUCTION:

The system which ignites the compressed Airfuel mixture at the end of compression stroke is called Ignition System. It is an electrical system which carries electrical current to the spark plug which gives electric spark to ignite the air fuel mixture. The Ignition system supplies high voltage upto a maximum of 24000 volts to the spark plug. The voltage produce electric spark at the spark plug gap between central and ground electrodes for the purpose of Ignition.

TYPES OF IGNITION SYSTEM:

- There are two types of Ignition systems used in petrol engines
1. Battery Coil Ignition system
 2. Magneto Ignition system
 3. Electronic Ignition System

1. Battery coil Ignition system: In Battery Coil Ignition system the current in the primary winding is supplied from the battery.

This system consists of Battery, Ammeter, Ignition switch, Ignition coil, Condenser, contact breaker points, Distributor and spark plugs.

The primary Ignition circuit starts at the battery and passes through the switch, Ammeter, primary winding, contract Breaker points tot the ground. A condenser is also connected in parallel to the contact breaker points. One end of condenser is connected to thte contact breaker arm and the other and is grounded.

The secondary Ignition Circuit starts from the ground and passes through the secondary winding, distributor, spark plug to the ground.

The Ignition coil steps up the voltage of 6 or 12 Volts received from the battery to the high tension voltage of about 20000 to 24000 volts required to jump the spark at the spark plug gap which ignites the combustible charge in the cylinder.

The rotor of distributor revolves and distributes the current to the segments which in trun send it to the spark plugs as per the number of cylinders.

The purpose of condenser is to reduce arcing and pitting of contact breaker points.

When the ignition switch is on, the current will flow from the battery through the primary winding . It produces magnetic field in the coil. When the contact points open, the magnetic field collapses and the movement of magnetic field induces current in the secondary winding coil in which many more turns of fine wire will increase the voltage up to a maximum value which is required for jumping of spark at the spark plug gap. The distributor then directs this high voltage to the proper spark plug as per the firing order arranged in the distributor rotor. This gives spark to the required spark plug.

(Fig 17.1 in Page 412 of RBG)

2 Magneto Ignition System: In this system the Magneto produces and supplies current in the primary winding. The magneto consists of a fixed armature having primary and secondary winding and rotating magnetic assembly which is driven by the engine . When the magnets rotate current flows in the primary winding. The Secondary winding gives high voltage current to the distributor which distributes it to the respective spark plugs according to the firing order.

In a magneto, the magnetic field is produced by means of permanent magnets. The magneto may be either rotating armature type or rotating magnet type.

Ignition Coil:It is simply a transformer to step up the Voltage in the ignition system. It consists of a soft iron core, primary winding and secondary winding. The primary winding consists of 200 to 300 turns of thick wire and the secondary winding 15000 to 20000 turns of fine wire. The Core is formed by lamination of soft iron.

When the ignition switch is turned on, the current follows from the battery through the primary winding. When the Contact Breaker Points open the primary circuit breaks and magnetic field collapses and induces high voltage in both primary and secondary winding.

Contact Breaker Points: The contact breaker is a mechanism to make and break the primary circuit of the Ignition system for obtaining high voltage current in the secondary circuit.

The main parts of a contact breaker are cam, contact points, leavers, rubbing block, spring and bush. The heel and bush are generally made of plastic.

DISTRIBUTOR: In Multi cylinder engine, the high voltage current from ignition coil is distributed to the required spark plug according to the firing order. The distributor consists of a housing, driving shaft with breaker cam, breaker plate with contact points, governor, condenser, rotor, advance mechanism and cap. A rotor is mounted on the breaker can which is carried by the drive shaft.

The distributor opens and closes the circuit between the battery and the ignition coil. During closing of circuit the current flows in the ignition coil and builds up a magnetic field. While opening the magnetic field collapses and high voltage current is produced by the coil. It distributes this high tension current to the proper spark plug at correct time as per the firing order.

SPARK PLUG: Spark plug is a device to produce electric spark to ignite the compressed air fuel mixture inside the cylinder. The spark plug is screwed in the top of the cylinder so that its electrodes project in the combustion chamber. It consists of mainly three Parts.

1. Center electrode (or) Insulated electrode
2. Ground electrode (or) Outer electrode
3. Insulation separating the two electrodes

The High tension lead from Ignition coil is connected to the center electrode terminal cap. The high voltage current then passes through the center electrode and jumps in the gap between the central and ground electrodes. The ground electrode is attached to the shell of the spark plug so that there is a gap of 0.4 mm to 1.0 mm. The Center electrode is surrounded by porcelain insulator. The lower half portion of the insulator is fastened with metallic shell in which screw thread of hexagonal shape is given to fit the spark plug into the cylinder head.

(Fig : 17.12 in page 424 of RBG)

FIRING ORDER:

The order or sequence in which the firing takes place in different cylinders of a multi cylinder engine is called firing order. The following are the most common firing orders in different engines.

3cylinder engine : 1-3-2 (Inline)

4Cylinder Engine: 1-3-4-2 (Inline)

6Cylinder Engine: 1-5-3-6-2-4(Inline)

8Cylinder Engine: 1-6-2-5-8-3-7-4(Inline)

8Cylinder V-type Engine: 1-5-4-8-6-3-7-2(Inline)

ELECTRONIC IGNITION SYSTEM:

In this system an interrupter is provided in the distributor by an inductive impulse generator. A toothed rotor made from soft magnetic steel produces magnetic flux changes in a permanent magnet during its rotation. The flux changes effect voltage impulses in the ignition coil surrounding the magnet. These control impulses which are modified and amplified electronically actuate the switching transistor and thus produce the ignition voltage.

CHAPTER 9

CHARGING SYSTEM

Introduction:

This system is necessary in Automobiles, where the storage battery is the main source of electricity. By this system, the electricity is replaced in to the battery after being used in starting system, lighting system and etc. Usually the Automobile generators are low voltage D. C generators producing direct current, because the use of battery requires direct current. In recent years, alternator type generators are also used. The alternator employs Diodes to convert the generated alternating current into direct current.

WORKING PRINCIPLE OF D. C . GENERATOR:

When a conductor is moved in a magnetic field, a current is produced in it. The direction of flow of current is determined by Fleming's left hand rule. It gives relationship between the direction of lines of force direction of conductor motion and direction of current flow.

Construction and working of D C Generator:

Mostly Commutator type D C Generators are used in Automobiles. It consists of pole pieces fitted in a frame armature commutator and filed winding. The pole shoes are the laminated iron cores for the filed winding that furnish the magnetic field for the generator. Most generators contain one pair of North-South poles, shaped to allow the armature to rotate between them with little clearance. The armature is made up of conductors of insulated wire around on a laminated iron core. The conductor ends are soldered to copper tabs, separated from each other by mica which make the commutator. A steel shaft running the armature and commutator is supported by means of bearing so that the pulley and fan mounted on the front end can be turned by an engine driven belt. Two carbon brushes are held in the brush holders, which make firm contact with commutator segments in order to connect the coils of rotating armature with the outside circuit.

Working: When the armature rotates, the current is induced and flows in the conductors through the load. Part of the current flow through the two field winding assemble around two magnetic poles. The magnetic field is strengthened. The Armature and commutator are designed to rot

AUTO TRANSMISSION SYSTEM ate together. They allow the generator to produ e a flow of direct current contin es to flow in the same direction.

Cutout:

The Cutout relay (or Circuit breakes) is an automatic device between dynamic and the battery which prevents the battery from discharging through the dynamo, when dynamo is not charging the battery. It is a magnetic switch and consists of two windings shunt winding and series winding. Closes the circuit between the generator and the battery when the generator is producing current.

Voltage Regulator:

The Voltage regulator consists of a relay coil wound with many turns of fine wire on the Iron core. The function of voltage regulator is to control the magnetic field circuit of dynamo. It consists of two windings on a single core, a shunt winding of many turns of fine wire and series winding of a few turns of heavy wire. The Shunt winding (Voltage winding) is connected at the input side of the cutout and grounded to the other end. The series or current winding is connected at one end to the filed circuit of the generator and at the other end to the contact point of armature.

Current Regulator:

It consists of electromagnet coil of heavy wire design to carry the full current. Electromagnet controls a pair of contacts. When the contacts are closed and the dynamo speed is more, an increasing current flows through the coil of the electromagnet. When the current is too high, the magnetic pull will over come the tension of the spring and the contacts are separated. When the contacts open, the filed current is reduced causing reduction of out. When the current is less the electromagnet pull is reduced and again the contacts close.

CHAPTER 10

STARTING SYSTEM

Construction and working of a Self Starter:

The electrical energy is converted into mechanical energy in starting motor or self starter. When a current carrying conductor is placed in a magnetic field, a mechanical force is experienced by a conductor, the direction of the force given by Fleming's right hand rule.

In a starting motor the brushes are made of low resistance material such as copper. The main parts of starting motor are Casing, Armature, Commutator, field winding brushes, poles and terminals. A drive mechanism is provided at the end of the armature shaft by means of which the motor starts the engine.

Drive arrangement:

The Starting motor is linked to the engine fly wheel through a set of gears. A pinion gear is attached to the starter armature which drives a ring gear attached to the fly wheel.

Type of Drive Arrangements:

1. Inertia Drive
 - a) Bendix drive
 - b) Folo-thru drive
- 2 Over running clutch drive

Bendix drive:

It is fastened in the armature shaft of the starting motor. An internal threaded pinion gear is mounted on the threaded sleeve. When the starting motor is at rest the switched on, the armature begins to rotate. The pinion, because of its inertia of rest and its unbalanced weight turns very little but moves forward and engages with the teeth of fly wheel.

When the fly wheel turns the crank shaft also turns and the engine starts. After the engine has started, the pinion gear is turned by the engine much faster. This causes the pinion gear to turn back on the threaded sleeve making it disengaged with fly wheel.

(Fig 16.7 in 404 RBG)

Over running Clutch drive:

In this drive the starter lever is linked to a starter pedal. The shift lever compress the drive shaft and spring which ultimately pushes the over running clutch and pinion gear assembly towards the fly wheel. When the engine starts, the over running clutch comes into action. As the starting motor runs, the pinion is driver through the over running clutch. But as soon as the engine starts the pinion turns much faster than starting motor, due to which it slips backward into the over running clutch.

(Fig 16.9 : in Page 406 in R B G)

CHAPTER 11

LIGHTING, HORN AND WIPERS

INTRODUCTION:

The Automobile lighting consists of Head lights, side lamps, tail lamps, reverse lamp. Apart from these there are panel lights, direction indicator flash lights and the lights inside the body to light up the passenger compartments.

In addition to lights some other instruments like wind screen wiper, meter lights etc are also being used in Automobiles.

LIGHTING: The lighting system includes Head lights, side lights, tail lamps etc.

HEAD LIGHTS: The requirements of head lights for Automobiles is that these should illuminate the road ahead at a reasonable distance with sufficient intensity. For this purpose a reflector is used. The light emitted from filament is reflected by means of the reflector into a beam of parallel rays.

These lights are usually provided with two beams, one gives maximum illumination for night driving and the other gives deflection to the ground and to the side of the road to minimize glare when passing other cars on the road. A third beam is used which is of low intensity for city driving.

HEAD LIGHT AIMING: The head lights should be aimed correctly to get proper illumination to the road and they should also not dazzle the opposite driver and thereby preventing accidents. For aiming there will be screws on both sides of head light frames which can be adjusted. The following procedure may be adopted.

- i) Place the vehicle in front of a screen at a distance of 25ft from it. Take care that the ground must be perfectly level.
- ii) Mark a line on the screen at a distance, 'C', from the ground such that $C=D-Z$ in case of Ashok Leyland and $C=D$ in case of Hindustan Ambassador Car.
D= Height of the Head light center line from the ground in inches.
(For other vehicles, usually the Manual of manufacturers may be followed)

- iii) Mark the Screen vertical lines A and B which are in line with head lights, the distance between them being equal to the distance between head lights.
- iv) Adjust the Aiming screws so that the glaze is correct on the screen.

SEALED BEAM HEAD LIGHTS:

Two beam head lamp system called the sealed beam head lamps system is used in now a days for Maximum illumination of roads. In this system both the head lamps are alike and produce a straight a head beam and a deflected lower or traffic beam. These are permanently sealed beam lights and the entire unit should be replaced if required.

PARKING LIGHTS

These lights are usually provided in front of the car usually as separate units or in some case in the Head lights also. These are of low intensity just to know the ongoing driver of the road that a vehicle is parked on the road.

TAIL OR STOP LIGHT: Tail lights illuminate back of the car in the night so that the other vehicles coming behind it can see the vehicle. These are also used as braking lights also. While braking these lights also will glow in addition to brake lights. Tail lights will continuously glow while driving in night.

Stop Lights or Brake lights will glow while braking only.

DASH LIGHTS: Dash lights are provided in the dash board or 'Meters Panel' in front of the driver so that he will be able to look at all the meters while night driving.

DIRECTIONAL SIGNAL LIGHTS: These lights are used to indicate the direction in which the vehicle is to turn. These lights will give signal to the vehicle coming from the front or rear.

DIM DIPPER: It is a switch provided at the dash board or beside the brake pedal at the convenient reach of the driver. It is used to operate the head light with high beam or low beam (whether it has to glow bright or Dim) . It is provided to control the focus of light so that it will not dazzle the opposite driver while night driving.

DOOR LIGHT: These lights will glow when the door is opened and will warn the driver that the door is not closed. When closed only, these lights will stop. A button is provided at the handle of the door to operate these lights.

DESINATION BOARD LIGHTS: For Buses and other important transport vehicle the destination board should glow properly so that the passenger can look into it properly for his traveling. For this purpose special lights are provide at them.

HORN CIRUIT: The Horn is provide in vehicles to create sound and warn the trespassers and other vehicles traveling on the road and make them alert to avoid accidents.

The Horn circuit consists of a horn push button, an armature, a diaphragm and a horn along with horn relay.

When the Horn button is pushed, it connects the Horn winding to the Battery. The current passing through the winding produces magnetic field which pulls the armature down. The armature is attached to the diaphragm opens the contact points and circuit is broken. This cycle is repeated rapidly which causes rapid movement of diaphragm. Which causes noise. A relay is used to avoid carrying heavy current required by the horn. (Fig 10.24 Page 533 K Singh)

WIND SCREEN WIPERS: These are provided to keep the wind screen clean during rain, snow etc to ensure good visibility. These are operated by means of a small motor. The wiper motor is a shunt wound motor and is mounted just below the wind screen under the hood.

SPEEDOMETER: Even though it is known as speedometer only this units consists of two separate units called as SPEEDOMETER and ODOMETER. The Speedometer shows the Speed of the Vehicle at which it is traveling. The odometer shows the distance traveled by the vehicle.

The Speedometer consists of permanent magnet over which is supported a well balanced speed cup to which is attached a Spindle carrying a pointer at the top. The magnet is driven directly by the vehicle transmission box or incase of two wheelers by the worm in the front wheel . A torque is produced by the rotating magnet to which spindle is attached. The pointer attached to spindle will be operated.

The magnetic shaft of the speedometer is provided with a worm gear which drives the odometer spindle through suitable gearing arrangement.

CHAPTER 12

BATTERY

INTRODUCTION:

The Battery is the main part of the electrical system in an Automobile. The battery supplied current for operation of the starting motor and ignition system when the engine is being cranked for starting. It also supplies current for light, radio, heater and several other accessories.

Types of batteries:

1. Lead acid battery
2. Alkaline battery
 - a) Nickel iron type
 - b) Nickel cadmium type
3. Zinc Air battery

LEAD ACID BATTERY: The lead acid battery is most widely used in automobiles. It consists of the following components.

1. Container
2. Plates
3. Separators
4. Cell covers
5. Electrolyte

1. Container: It is a single piece construction and is made of hard rubber or bituminous material. It is divided into compartments by partitions for different cells.

2. Plates: The plates in the battery consists of perforated grids into which lead or lead peroxide has been pressed. There are two types of plate groups in each cell positive plate group and negative plate group. The plate group connected to the positive terminal of the cells consists of the grids filled with a paste of Lead Peroxide. The negative plate group consists of Metallic lead.

3. Separators: Separators are placed between the negative and positive plates to keep them separate with each other. These are usually made of special treated wood, hard rubber etc.

4. Cell Cover : Each cell is covered by a cover of hard rubber through which the positive and negative terminals project.

5 Electrolyte: The electrolyte used in the lead acid battery is the solution of sulphuric acid. It consists of 40% of sulphuric acid and 60% of distilled water. The level of electrolyte should be about 10 mm over the tops of the plates.

CHEMICALS USED IN BATTERY:

The chemicals used in a Battery are as follows

1. Sponge Lead (Solid)
2. Lead Oxide (Paste)
3. Sulphuric Acid (Liquid)

The chemical reactions take place between the three chemicals in the battery. In the presence of sulphuric acid, the electrons from one group of plates collect on the other group of plates.

The following chemical reactions take place while charging and discharging.

While charging : At Anode (+ve Plate):

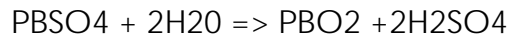

At Cathode (-ve Plate)

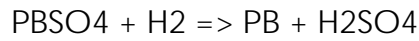

During Discharge : The acid H_2SO_4 attacks lead to form $PbSO_4$ (Lead sulphate)

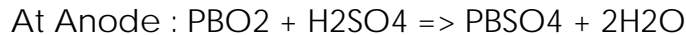

At Cathode SO_4 combines with it to form $PbSO_4$.

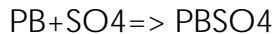

So both at anode (Ve) and at Cathode (-ve) $PbSO_4$ is formed. During this process water is also formed which dilutes sulphuric acid and thereby decreases its specific gravity.

This the battery converts electrical energy into chemical energy during charging and chemical energy into electrical energy during discharging.

BATTERY EFFICIENCY:

The capacity of a fully charged battery falls down to a much lower value in fully discharged state. To know the capacity of battery two methods are adopted.

1. Ampere Hour efficiency
2. Watt Hour efficiency

$$\text{NahB} = \frac{\text{Ah at full discharge}}{\text{Ah at full charge}}$$

$$\text{NWhB} = \frac{\text{Wh out put at full discharge}}{\text{Wh input at full charge}}$$

(Watt = volt X ampere)

BATTERY TESTING :

A battery can be tested to ascertain its condition by the following tests.

1. Specific gravity test
2. Open Volt test
3. High discharge test
4. Cadmium tip test

Specific gravity test : While the chemical reaction taking place in the battery during discharge, the electrolyte becomes dilute to form water. The proportion of water goes on increasing as the discharging continues. The relative amounts of water and acid is determined by the specific gravity test. This is done by Hydrometer. The Meter of Hydrometer ranges as follows:

Reading	Condition
1.260 to 1.280	Fully charged
1.230 to 1.250	$\frac{3}{4}$ charge
1.200 to 1.220	$\frac{1}{2}$ charge
1.170 to 1.190	Very little charge
1.110 to 1.130	Completely discharged

ii) Open Volt test : The Open circuit voltage of a fully charged battery cell is about 2.1 volts. This can be measured with the help of a voltmeter. It can be observed that a charge of 0.01 Volt of open circuit voltage is equivalent to a charge of 0.010 in the specific gravity of the electrolyte.

High discharge test : High Voltage of current is required for cranking the starting motor. To satisfy this condition, high discharge test is done with the help of cell voltage tester.

Cadmium Test : The test is done to ascertain whether the battery plates are defective or not. It is done with help of cadmium rod enclosed in a perforated ebonite tube. The rod is immersed in the electrolyte and connected to the negative terminal of a Voltmeter. Its positive terminal is connected alternately to the positive and negative terminals of a battery cell. When connected with positive terminals, the voltage reading should not be less than 2.5 Volts. If it is less it indicates defective positive plates. When connected with negative plates, if it is more than 2.5 Volts, it indicates defective negative plates.