

A Text Book on Auto Powerplant
(A text book for +2 Vocational and Diploma Students of Mechanical
Engineering)

Author

Sri. U.V.N.Varma
Lecturer in Vocational,
Department of Vocational Education,
Government Junior College, Pendurthy.

Editor

Sri. K.S.Raghu Ram,
Lecturer in Vocational,
Department of Vocational Education,
Dr.V.S.Krishna Government Junior College(Boys),
Visakhapatnam

CONTENTS

1. Introduction to engine.
Engine – types of engines – function of I C engine – Classification of I C Engines
2. Petrol Engines
Materials used – function and constructional details of petrol engines – Cylinder arrangement – Side valve operating mechanism – valve clearance – Comparison between 2 stroke and 4stroke engines – Valve timing diagram of 2 stroke and 4 stroke engines – firing order of multi cylinders.
3. Petrol engine fuel system
Line diagram of petrol engine fuel system – constructional details of fuel tank, fuel tanks – construction and working of fuel pumps – Requirements of automobile carburetor – Air fuel ratio for different conditions – Arrangement of carburetors – construction and working of Carter, Zenith, Solex and S U Carburetor – Super charger and scavenger
4. Diesel engines
Working principle of 2 stroke and 4 stroke diesel engines – advantages and limitations of diesel engine over petrol engine – valve timing diagram of 2 stroke and 4 stroke diesel engines- types of diesel engine combustion chambers.
5. Diesel Engine fuel system
Line diagram of diesel engine fuel system – types of diesel fuel feed pump – Requirement of fuel injection system – types of Fuel injections – construction and working of FIP – Phasing and Calibration of FIP –

Construction and working of mechanical and pneumatic governors
– Function of injectors – types and their working.

6 LUBRICATING SYSTEM:

Types of lubricants – properties of lubricants – SAE number –
Requirements of lubrication for automobiles – Types of filters –
Necessity of crank case ventilation – Grades of lubricants used in
engine gear box, differential – steering gearbox in different type of
vehicles.

7. Cooling system

Types of cooling system – constructional details of air cooling system
– construction and working of forced feed type with thermostat
water cooling system – construction and working of water pump,
radiator – Anti freezing and anti rusting additives.

8. Manifolds and Mufflers

Necessity of inlet and exhaust manifold – consideration for a good
manifold design – types of manifolds – inlet and exhaust manifolds –
air cleaner – different types of silencers – functions of silencer.

9. Performance of IC engines

Need for engine performance testing – different types of engine
powers – BHP, IHP and FHP – different types of engine efficiencies i.e.
brake thermal efficiency, indicated thermal efficiency, volumetric
efficiency – Specific fuel consumption – Heat balance sheet –
performance curves.

1. Engine

Introduction: An automobile is a self propelled vehicle which is used for the transportation of passengers and goods upon the ground. Auto means automatically and mobile or motive means one which can move. Automobile engineering is a branch of mechanical engineering and have practice to propel them. Car, bus, truck, jeep, tractor, scooter, motorcycle are examples of automobiles.

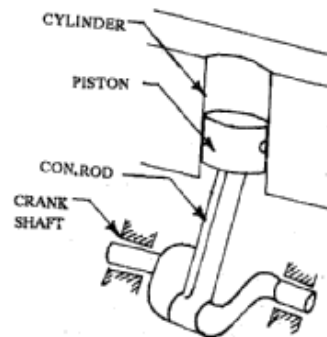

1.1 ENGINE: It is a machine which converts heat energy into mechanical energy.

It should be understandable that the energy supplied to the engine is of the chemical form like diesel or petrol or kerosene. This chemical energy is converted into heat energy by the process of compression or spark ignition inside the engine. The heat energy is then converted into mechanical energy.

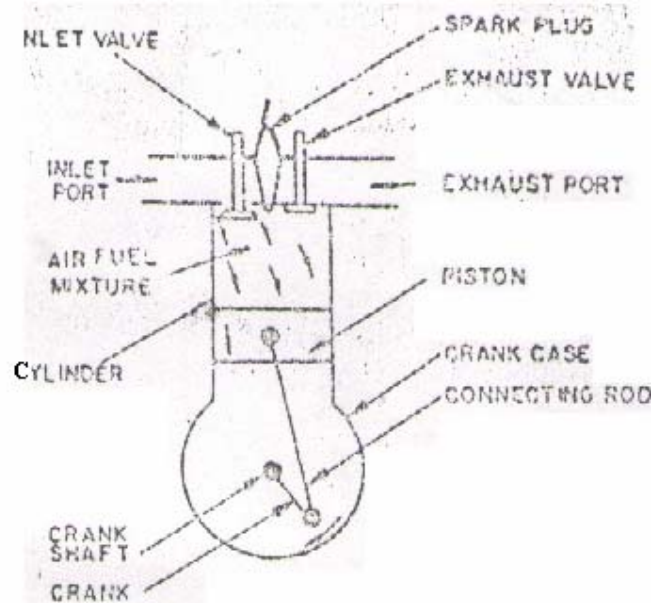

1.2 Types of engines: Mainly engines are of two types.

External Combustion Engines (E.C. Engines) E.g.: Steam Engines.

Internal Combustion Engines (I.C. Engines) E.g.: All Automobile Engines.

External Combustion Engines: The External Combustion Engines are those in which the combustion takes place outside the engine cylinder. E.g.: Steam Engine.

Internal Combustion Engines: In the Internal Combustion Engines the combustion of fuel takes place inside the engine cylinder. E.g.: All Automobile Engines.

1.3 Functions of I.C. Engine: Engine is that kind of prime mover which converts chemical energy of fuel into mechanical energy. The fuel on burning changes to gas which impinges upon the piston and pushes it to change into reciprocating motion. The reciprocating motion of piston is then converted to rotary motion of crank shaft with the help of slider mechanism involving connecting rod and crank shaft.

Several types of I.C. Engines are used on various automobiles i.e. marine, locomotive, air craft and other industrial applications.

1.4 Classifications of I.C. Engines: The I.C. Engine can be classified on the basis of

1. Working cycle:
 - a. Otto cycle Engine or Spark Ignition Engine (S.I.Engine)
 - b. Diesel Cycle Engine or Compression Ignition engine (C.I. Engine)
2. Number of strokes:
 - a. Two Stroke engine
 - b. Four Stroke engine.
3. Fuel used:
 - a. Liquefied petrol engines
 - b. Diesel engines
 - c. Gasoline or petrol
 - d. Compressed Natural gas engines,
 - e. Methane or ethanol engines.
4. Fuel supply system:
 - a. Fuel supply through carburetor
 - b. Fuel injected by Fuel injecting pump.
5. Method of ignition:
 - a. battery or coil ignition
 - b. Magneto ignition
 - c. Electronic ignition
6. Method of cooling:
 - i) Air cooled
 - ii) Water cooled
7. Cylinder Arrangement:
 - i) in line type
 - ii) V type
 - iii) Opposed cylinder type
 - iv) Radial type
8. Valve operating system:
 - i) Overhead type

ii) Side valve type

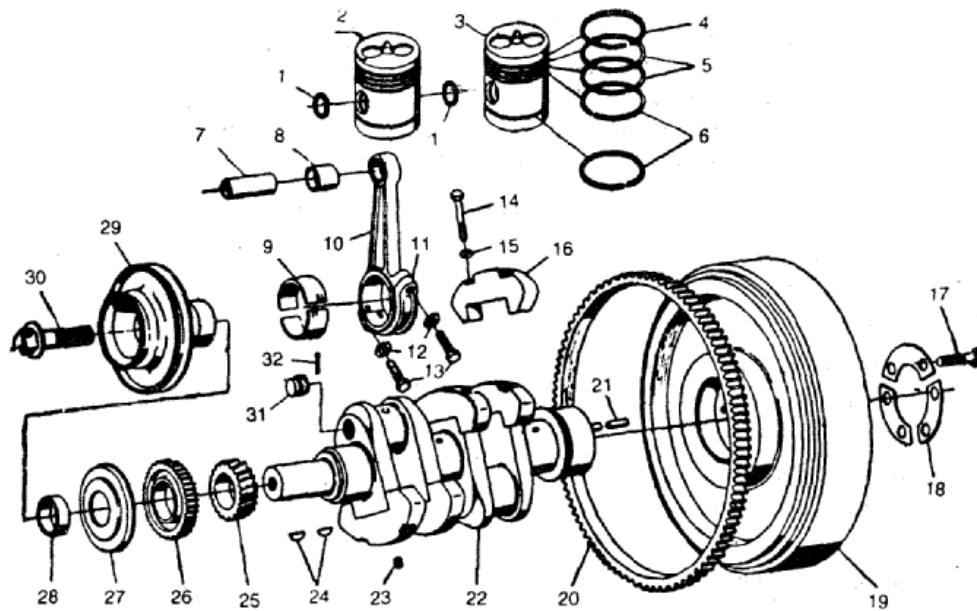

1. Circlip. 2. Piston, first cylinder. 3. Piston, second cylinder. 4. Ring, piston, compression chromium coated. 5. Ring, piston, compression. 6. Ring, piston, scrapper. 7. Piston pin. 8. Bushing, connecting rod small end. 9. Bearing bush, complete, connecting rod. 10. Connecting rod. 11. Cap, connecting rod, big end. 12. Tab washer. 13. Bolt connecting rod. 14. Bolt. 15. Tab washer. 16. Counter weight. 17. Bolt. 18. Gasket. 19. Flywheel. 20. Toothed ring, flywheel. 21. Cap connecting rod big end. 22. Crankshaft. 23. Screw. 24. Woodruff key. 25. Gear, Z = 23. 26. Gear, Z = 38. 27. Oil retainer. 28. Bushing. 29. Belt pulley. 30. Driving dog. 31. Plug. 32. Split pin. 33. Split pin.

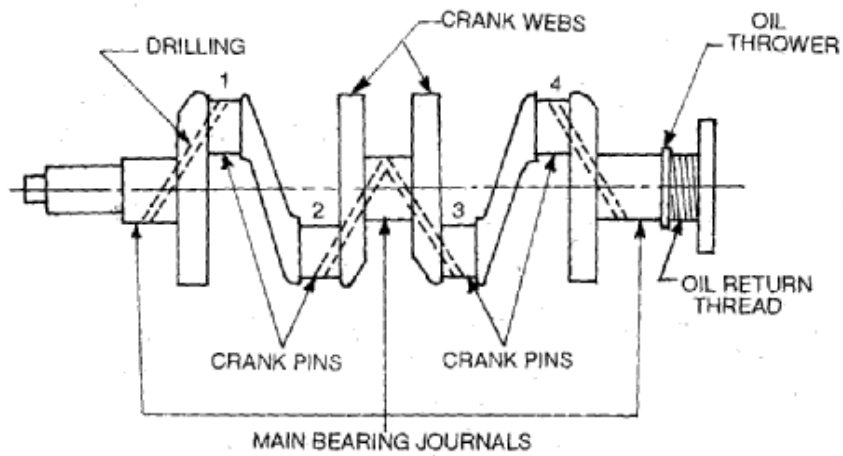

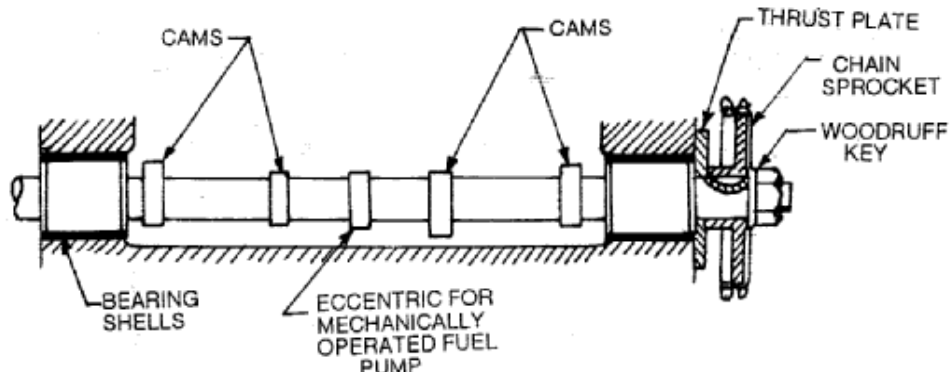
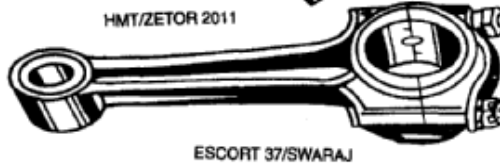
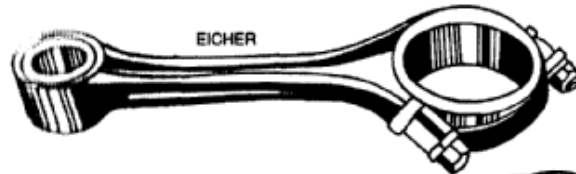
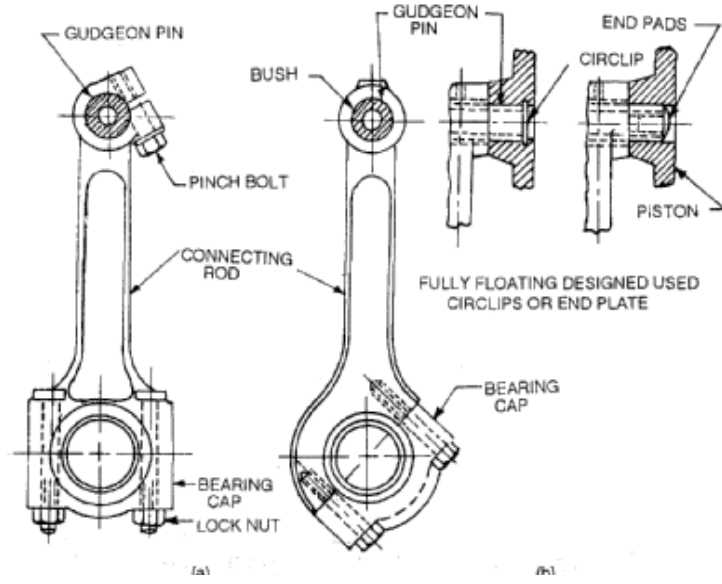

CAM SHAFT

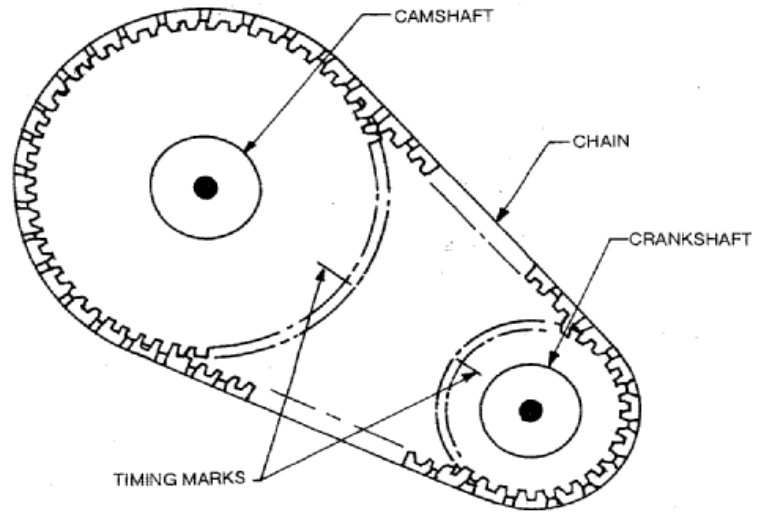

TIMING GEARS

Summary

1. Engine is the heart of an automobile.
2. Engines are widely used in the fields of automobiles, agriculture, power generators etc.
3. The identification of the engine can be justified by its physical appearance like spark plug, injector, valves etc.
4. Before the internal combustion engines, there is a wide usage of external combustion engines like steam engines
5. Steam engines are widely used in locomotive trains, sugar industries etc.
6. Radial engines are ancient type of engines.

Exercise

Short answer questions:

1. What is an engine?
2. How the energy converts in an engine?
3. What are the fuels used in an engine?
4. What is meant by I.C. engine and an E.C. Engine?
5. How do you mean by S.I. Engine?
6. How the petrol engine and diesel engine can be identified?
7. In which type of engine can you find the valves?
8. Name the engine in which ports are used.
9. What is meant by consumption of an engine?

Essay type questions:

1. How the engines are classified?
2. Discuss about the classifications of I.C. Engines?
3. Mention the differences of Internal Combustions and External Combustion engines.

2. Petrol Engines

2.1 Materials used, function and Constructional details of Petrol Engine Components

Engine consists of the following parts.

1. Cylinder block
2. Cylinder head
3. Crankcase
4. Piston
5. Piston Rings
6. Piston Pin
7. Connecting Rod
8. Crankshaft
9. Flywheel
10. Valves and valve mechanism
11. Rocker Arm
12. Camshaft

besides the above components engine contain so many accessories like air-cleaner, oil filter, automatic chokes, automatic heat controls, spark plug, ignition devices, carburetors, manifolds, vibration damper etc.

Materials used for various components:

The cylinder block and cylinder heat are made of gray cast iron and sometimes with addition of nickel and chromium. Some cylinder blocks are cast from aluminum, cast iron or steel. The cylinder blocks are made of casting process. Small engine cylinder blocks walls are plated with chromium to reduce wall wear and to increase their service life.

The cylinder gaskets are made of copper-asbestos, steel asbestos and stainless steel.

The upper part of the crankcase is made of ferrous alloy or semi-steel to provide a stronger and harder casing.

The cylinder liners are barrels made of special alloy iron containing silicon, manganese, nickel and chromium. The cylinder liners are centrifugal castings.

The piston is the most important part in the engine which converts chemical energy into mechanical power. As the piston is to convey the expansion of the gases via connecting rod it is made of aluminum alloy by the process of either cast or forged. As the conductivity of aluminum alloy is more than cast iron, it is made of aluminum alloy.

The piston rings are coated to minimize the wear. The piston rings are coated with chromium plating to decrease the rate of wear. Ring coating absorbs oil thus improving lubrication. The piston rings are castings.

The connecting rod is generally I-beam cross-section and is made of forged steel. Aluminum alloy is also used for connecting rods. But they are carefully matched in sets of uniform weight in order to maintain engine balance. The connecting rod is made of forging process.

The crankshaft is made of casting or forging of heat treatment alloy steel and is machined and ground to provide suitable journals for the connecting rod and main bearings.

The flywheel is a fairly heavy bulk mass of steel attached to the crankshaft. The size of the flywheel depends upon the number of cylinders and the general construction of the engines. During the power stroke the engine tends to speed up and during the other three strokes it tends to slow down. The inertial of the flywheel tends to keep it running at constant speed.

The valves are usually made of austenitic stainless steel which is a corrosion and heat resistant material. Exhaust valve is made of silchrome steel which is an alloy of silicon and chromium with unusual resistance to heat. Inlet valve is usually made of nickel chromium alloy steel.

2.2 Cylinder arrangement of Petrol engines

The classification of petrol engines on the arrangement of cylinder is as follows.

1. Inline arrangement – 2 in line, 3 inline, 4 inline, 6 inline and 8 inline.
2. V arrangement – v-4, v-6, v-8 and v-12.
3. Opposed cylinder or flat arrangement – flat 2, flat 4 and flat 6.
4. Radial cylinder arrangement.

2.3 Construction and working of 2 Stroke and 4 stroke engines

Two Stroke engine:

The two stroke engine there are two strokes namely upward stroke and downward stroke. In a two stroke engine, the two strokes are completed in two strokes of the piston or one complete revolution of the crankshaft.

Upward stroke: during the upward stroke the piston moves upward from bottom dead centre to top dead centre. The air fuel mixture or air is compressed in the combustion chamber of the cylinder. Due to upward movement of the piston, a partial vacuum is created in the crankcase, and a new charge is drawn into the crankcase through the uncovered inlet port. The exhaust port and transfer port are covered when the piston is at top dead centre position. The compressed charge is ignited in the combustion chamber.

Downward stroke: As soon as the charge is ignited, the hot gases compress the piston which moves downward, rotating the crankshaft thus doing the useful work. During this stroke the inlet port is covered by the piston and the new charge is compressed in the crankcase. Further downward movement of the piston uncovers first the exhaust port and then the transfer port, and hence the exhaust starts through the exhaust port. As soon as the transfer port opens, the charge through it is forced into the cylinder. The charge strikes the deflector on the piston crown, rises to the top of the cylinder and pushes out most of the exhaust gases. The piston is now at bottom dead centre position. The cylinder is completely filled with the fresh charge, although it is then repeated, the piston making two strokes for each revolution of the crankshaft.

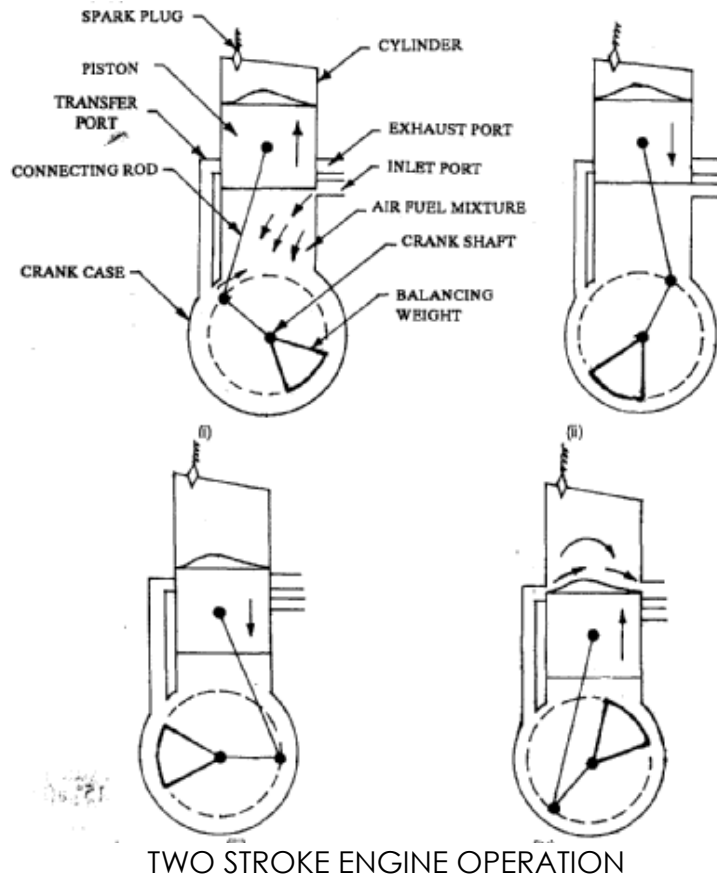

Four Stroke Engine:

The four stroke engine comprises of suction, compression, power or working and exhaust strokes.

1. **Suction Stroke:** When the piston moves from TDC to BDC the inlet valve opens and due to the downward movement of piston a partial vacuum is created in the cylinder above the piston. Due to this partial vacuum air is sucked in at the end of stroke the inlet valve closes.
2. **Compression Stroke:** When the piston starts moving from BDC to TDC the air which has been trapped in the cylinder starts getting compressed, when the piston reaches near TDC, the trapped air gets so compressed that its temperature reaches between 500°C to 650°C . This higher increase in temperature is because of higher compression ratio, in this stroke both valves remain closed.
3. **Power Stroke:** At the end of compression stroke diesel oil is sprayed in fine atomized form to the burning hot air which has attained temperature of approximately 500° to 650°C here we would like to mention that self ignition temperature of diesel fuel at atmospheric pressure is 350°C to 450°C as such atomized fuel in hot air gets ignited in more or less rapid explosion making gases to expand. We have earlier studied that piston is the only moving part in the cylinder.
4. **Exhaust Stroke:** In this stroke, the exhaust valve opens and due to moving of piston from BDC to TDC, the burnt gases are pushed out. The inlet valve opens in suction stroke but as a matter of fact it opens 10° to 22° before TDC in exhaust stroke. So that valve is fully open when piston

starts moving down and enough time is given for air to get it. The inlet valve remains open in compression stroke 20° to 30° after BDC. This once again is to allow air which was coming to cylinder to cylinder with great velocity to fill cylinder completely.

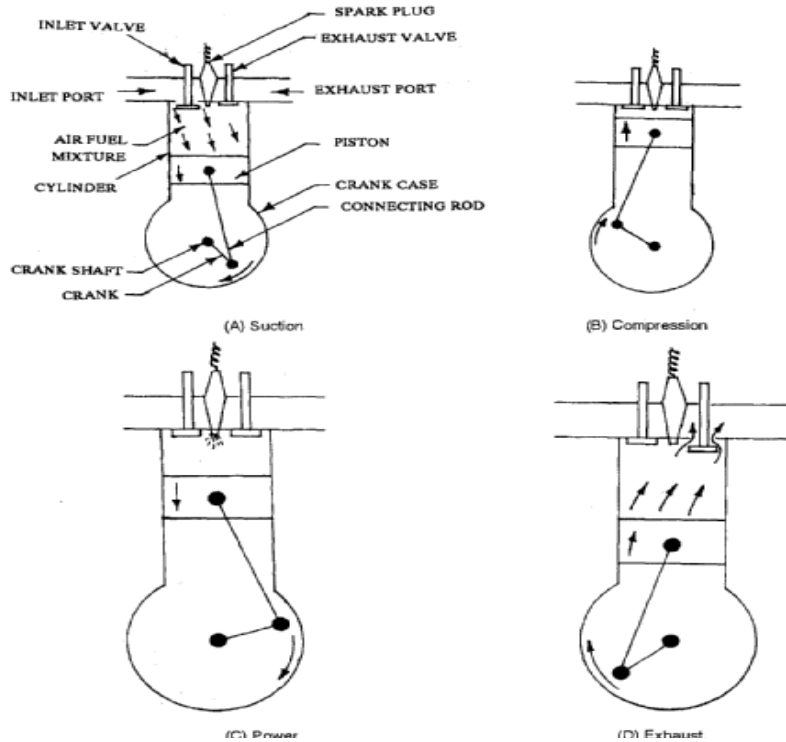

2.4 Side valve and over head valve operating mechanisms

The valves used in four stroke engines are operated by two mechanisms.

1. valve mechanism for operating the valve in engine block or straight or side valve mechanism.
2. Valve mechanism for operating the valve in cylinder head or over head valve mechanism.

Side valve operating mechanism:

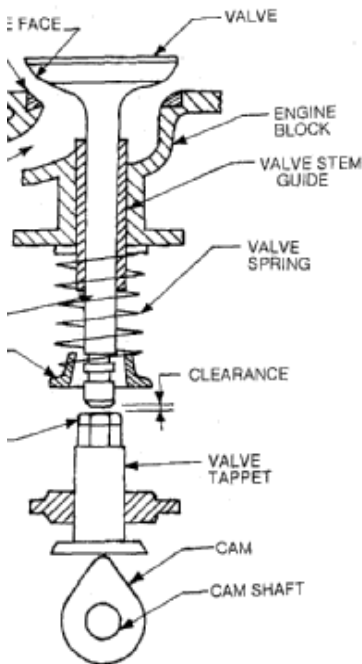

Operating the valve in engine block. (Straight poppet valve).

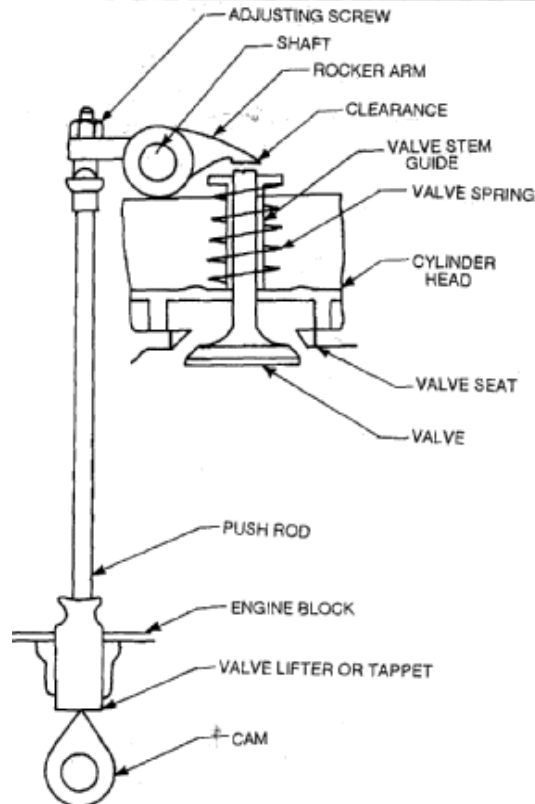

Overhead Valve Mechanism.

This mechanism is used in the engine block. It is mostly adopted in L,T and F type engine heads. The valve stem slides up and down in the valve stem guide which acts as a slipper bearing. It also prevents the gases from passing from the valve port to the valve chamber of the engine block. Valve spring is fitted between the engine block and spring retainer, which keeps the valve closed tightly on the valve seat, until lifted by the valve tappet by the rotation of the cam. The tappet or lifter is held between guide which is generally a part of the engine block. Adjusting screw is provided on the tappet to adjust the clearance between the upper end of the tappet and the bottom of the valve stem. As the cam rotates, it lifts the tappet which lifts the valve to the open position thus connecting the valve part to the combustion chamber.

Valve seat inserts are fitted on the valve seats. These inserts are in the form of rings tapered grounded to suit the valve faces, and made of special alloy steels. Usually they are used only on exhaust valve seats. They reduce wear and can be replaced when worn out.

Over head valve mechanism:

It is used in I type and F type engine heads. This type valve operating mechanism requires a push rod and a rocker arm.

As the cam rotates, it lifts the valve tappet or the lifter which actuates the push rod. The push rod rotates the rocker arm about a shaft- the rocker arm shaft, or a ball joint in some designs to cause one end to push down on the valve stem to open the valve, thus connecting the valve port with the combustion chamber. In this mechanism, the valve tappet clearance is between the rocker arm and valve stem. It is adjusted by means of an adjusting screw on the rocker-arm end that contacts the push rod.

2.5 Comparison between 2 stroke and 4 stroke petrol engines

Two Stroke Engine	Four stroke engine
1. One working stroke in each revolution of the crankshaft.	One working stroke for every two revolutions of the crankshaft.
2. Turning moment on the crankshaft is more even due to one working stroke for each revolution of the crankshaft. Hence lighter flywheel is required and engine runs balanced.	Turning moment on the crankshaft is not even due to one working stroke for every two revolution of the crankshaft. Hence heavy flywheel is required and engine runs unbalanced
3. Engine is light.	Engine is heavy.
4. Engine design is simple.	Engine design is complicated.
5. The engine is less in cost.	The engine is more in cost.
6. More Mechanical Efficiency due to less friction on a few parts.	Less mechanical efficiency due to more friction on many parts.
7. Less output due to mixing of fresh charge with the burnt gases.	More output due to full fresh charge intake and full burnt gases exhaust.
8. Engine runs hotter.	Engine runs cooler.
9. Engine is air cooled.	Engine is water cooled
10. More fuel consumption.	Less fuel consumption.
11. Fresh charge mixes with the burnt gases.	Full burning of fuel takes place.
12. Engine requires less space.	Engine requires more space.
13. Simple lubrication system.	Complicated lubrication system.
14. Engine creates more noise.	Engine creates less noise.
15. Generally used in mopeds, scooters, motor cycles etc.	Used in cars, buses, trucks. Presently using in motor cycles and scooters.
16. Engine consists of ports.	Engine consists of valves.
17. Less thermal efficiency.	More thermal efficiency.
18. It consumes more lubricating oil.	Consumes less lubricating oil.
19. More wear and tear of moving parts.	Less wear and tear of moving parts.

2.6 valve timing diagram of 4 stroke petrol engines

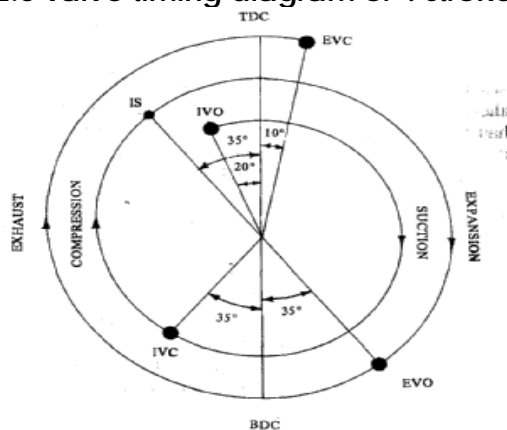

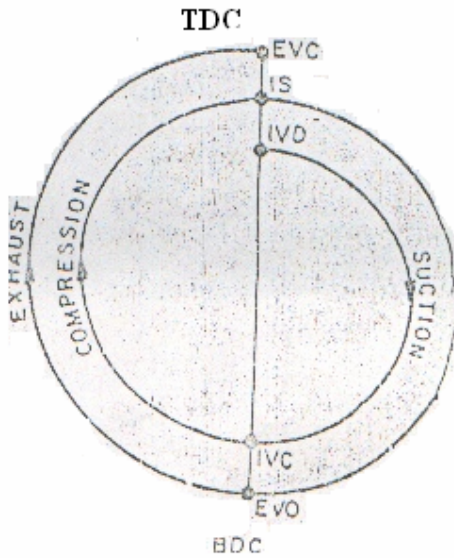

Theoretical Valve timing of a 4 stroke Petrol Engine

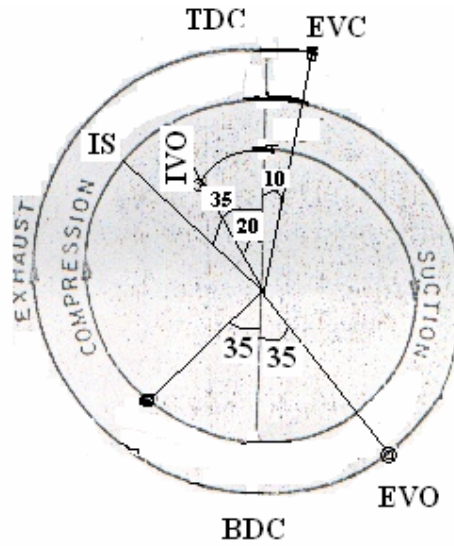

Actual Valve Timing for 4 stroke Petrol Engine

- IVO - Inlet valve Opens
- IVC - Inlet Valve Closes
- IS - Ignition Starts
- EVO - Exhaust Valve Opens
- EVC - Exhaust Valve Closes
- TDC - Top Dead Center
- BDC - Bottom Dead Center

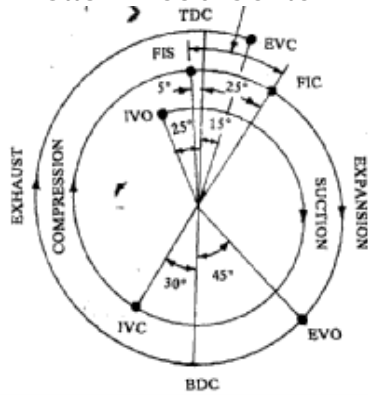

- IVO - Inlet valve opens
- IVC - Inlet valve closes
- FIS - Fuel injection starts
- FIC - Fuel injection closes
- EVO - Exhaust valve opens
- EVC - Exhaust valve closes

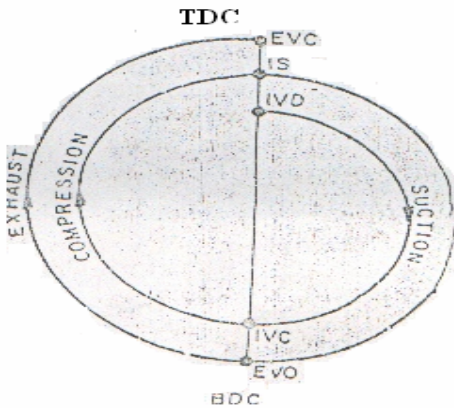

Theoretical Valve timing of a 4 stroke Diesel Engine

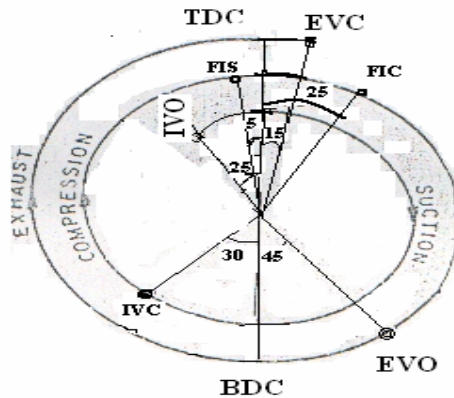

Actual Valve Timing for 4 stroke Diesel Engine

2.7 Firing order of multi cylinder engine

The sequence in which the power impulses occur in an engine is called the firing order.

The firing order for a four cylinder engine is 1-2-4-3 or 1-3-4-2

The firing order for a six cylinder engine is 1-4-2-6-3-5 or 1-5-3-6-2-4

The firing order for a V-6 engine is 1-6-5-4-3-2.

The firing order for an opposed six cylinder engine is 1-4-5-2-3-6

The firing order for an V-8 engine is 1-8-4-3-6-5-7-2.

2.8 Vibrations and use of vibrating dampers

The torsion vibration of the crankshaft causes oscillations called vibrations. The vibrations are controlled by vibration damper or harmonic balancer. These vibration dampers are usually fitted at the front end of the crankshaft and the fan belt pulley is incorporated into them.

A vibrating damper usually consists of two parts – a small damper flywheel and pulley, bonded with a rubber insert. The pulley is mounted to the front end of the crankshaft. With the speed of the crankshaft, the damper flywheel imposes rubber insert and tends to hold the pulley and crankshaft to a constant speed. Hence the vibrating damper releases the stress on the crankshaft.

Summary

- An engine is a device that converts chemical energy into mechanical energy.
- A petrol engine follows Otto cycle which comprises of two constant volume processes and two isentropic processes.
- A diesel engine follows a diesel cycle which comprises of one constant volume, one constant pressure and two isentropic processes.
- A petrol engine is called SI (Spark Ignition) engine or constant volume engine.
- A diesel engine is called CI (Compression Ignition) ignition or constant pressure cycle.
- The valve timing diagram shows the position of valve operation in the four strokes the engine.
- Port timing diagram is applicable for Two stroke engines.
- Gaskets are provided between the cylinder and cylinder head to prevent escape of gases.
- Cylinder liners are used for heavy duty engines.
- Piston clearance prevents piston seizure. It is helpful for film of lubrication.
- Combustion chamber is the space enclosed between the cylinder head and piston head, when the piston is at top dead centre position.
- Types of combustion chambers – Spherical shape, I shape, T shape, F shape and L shape.
- Combustion chambers for diesel engines – Open combustion chamber, Pre combustion chamber, Swirl combustion chamber, Squish combustion chamber and Air cell and Energy cell.
- Valve is a device to close and open a passage.
- The valves used in modern passenger car engines are termed as Poppet or mushroom valves.
- The angular face is ground on the valve head to make an angle of 45° or 30° to match the angle of valve seat in the cylinder head.
- Spring retainer lock groove is provided at the end of the valve stem.
- Beside diesel and petrol cars there are electric car, atomic car, steam car and turbine car.

Exercise

1. What is an engine? Name the types of engines.
2. List out the materials used for the construction of various engine parts.
3. Mention the constructional details of various engine parts.
4. What are the types of valve operating mechanisms used in automobiles?
5. What type of valve operating mechanism is used in L type engine?
6. In which type of engine the side valve operating mechanism is used?
7. List out the various types of cylinder arrangements used in automobiles.
8. Enumerate the construction and working of a two stroke engine.
9. With the help of a neat sketch explain a four stroke engine.
10. Explain about the valve timing diagram of a petrol engine.
11. Draw a neat sketch of a valve timing diagram of a diesel engine.
12. Give the firing order of a 4 cylinder engine.
13. What do you mean by firing order?
14. Write a short note on vibration damper.

3. PETROL ENGINE FUEL SYSTEM

3.0. Introduction: The fuel system of an Internal Combustion engine is intended to produce a combustible mixture composed of the fuel stored in the fuel tank and the atmospheric air, and then deliver both to the cylinders. Petrol engines use light grade gasoline.

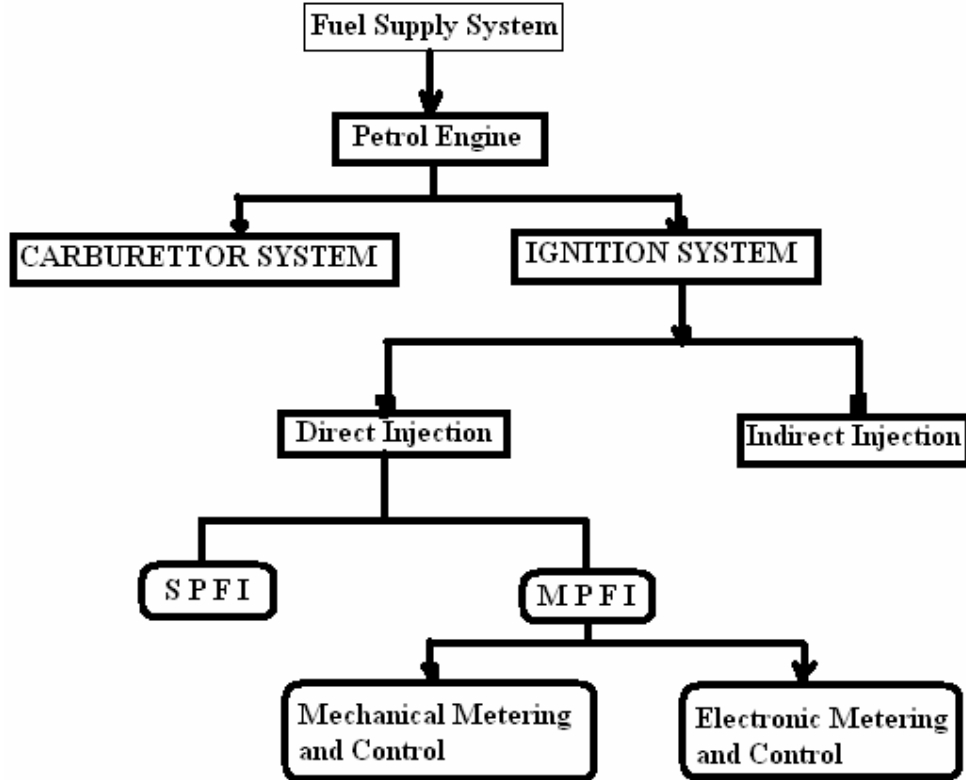

3.1. Components of fuel feed system: The fuel feed system of a petrol engine are having the following components.

1. Fuel Tank
2. Fuel Pump
3. Fuel Filter
4. Carburetor
5. Intake manifold
6. Fuel lines
7. Fuel Gauge

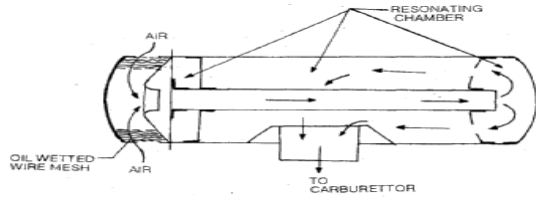

Oil Bath Type Air Cleaner

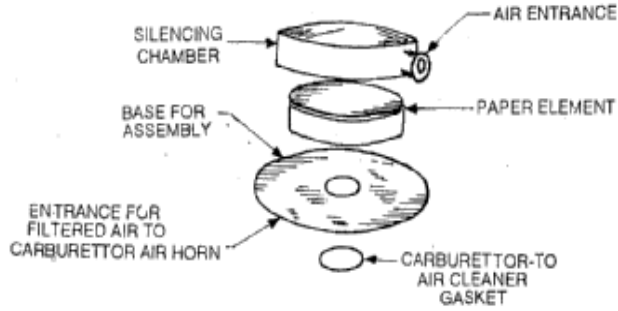

Dry Type Air Cleaner



Centrifugal Type air cleaner

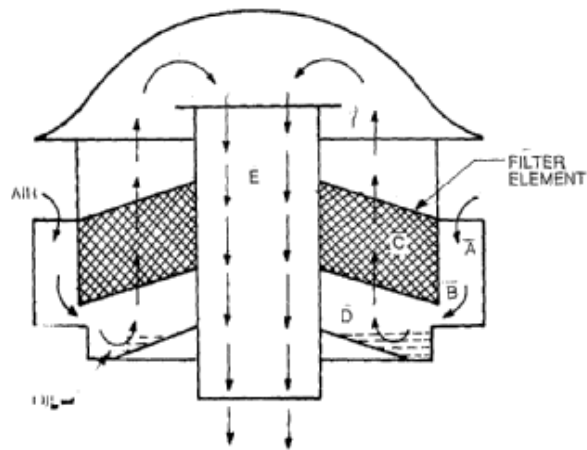

OIL BATH TYPE AIR CLEANER

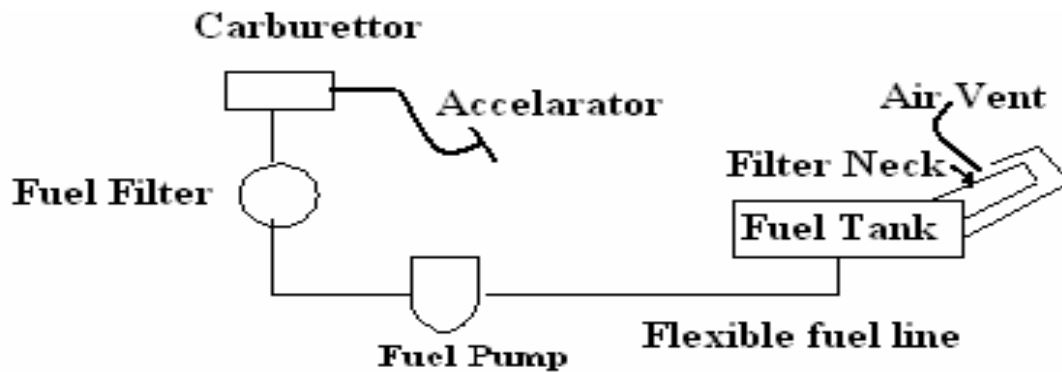

Types of Fuel Feed Systems: The fuel from the fuel tank can be supplied to the engine cylinder by the following systems.

1. Gravity System.
2. Pressure system
3. Vacuum System
4. Pump System
5. Fuel Injection System.

Functions of fuel feed system:

1. To store the fuel in the fuel tank.
2. To supply fuel to the engine to the required amount and in proper conditions.
3. To indicate to the driver the fuel level in the fuel tank.

In the gravity fuel feed system, the fuel tank is mounted at a place higher than that of the carburetor. The fuel flows from the tank to the carburetor due to the gravitational force. Thus the system does not require any fuel pump. The fuel tank is directly connected to the carburetor. Scooters and motorcycles use this system.

In pressure system, a pressure sealed tank is used. The pressure is created in the tank by means of a separate pump. For starting, the pump is primed by cam which produces pressure in the tank and fuel flows to the carburetor. In this system the tank can be placed above or below the carburetor.

In vacuum system, the engine suction is used for sucking the fuel from the main tank to the auxiliary fuel tank from where it flows by gravity to the carburetor.

In pump system, a fuel pump is used to feed the fuel from the fuel tank to the carburetor. The pump is driven either by the cam shaft or electrically. In this system, the fuel tank can be placed at any suitable position in the vehicle.

In the fuel injection system, a fuel injection pump is used in place of carburetor. The fuel is atomized by means of a nozzle and then delivered into an air stream. Separate fuel injection system is used for each cylinder which controls the mixture under different load and speed conditions.

3.2 Fuel Tank: The fuel tank is made of sheet metal. It is usually attached to the frame at a rear of vehicle. Its capacity ranges from 70 to 120 liters. The filler neck of the tank is closed by a cap. In some other tanks, there is a filtering element at the fuel line connection to prevent dirt and prevent it from reaching to the pump and carburetor. A drain plug is provided at the bottom for emptying the tank. The tank also contains the float unit of the fuel gauge. It may also have a vent pipe which allows air to escape when the tank is being filled. In the cars, that are equipped with vapor recovering system, the

vent pipe is connected to condenser which contains the vaporized gasoline in the tank and prevents its escape into the air.

Fuel line: The copper or steel tubes and hoses are used for connecting fuel tank with pump with carburetor. The tube connecting the fuel tank and pump is fastened rigidly to the frame or body. The first and last portion generally consists of a flexible tube that joints the rigid line to the fuel tank or to the pump. This allows the fuel tank to oscillate with the body and the pump with the engine without breaking or loosening the line.

Fuel Filters: The fuel is filtered at different stages in a fuel supply system. Therefore, many fuel filters are used in the fuel circuit. The fuel filter serves the purpose of filtration in the fuel delivery system by preventing foreign particles from entering into the fuel pump and the carburetor. The modern filtration practice employs a combination of coarse and fine filters.

Course filters are incorporated within the fuel tank.

Medium coarse filter are outside the fuel tank and on the inlet side of the pump.

Fine filters of built in surface type at inlet of fuel pumps pumping chamber.

Fine filter in pipe line is between fuel pump and the carburetor.

3.3 Fuel pumps: A fuel pump is used to deliver fuel from the fuel tank to the float chamber of carburetor. Main types of fuel pumps commonly used on auto vehicles.

1. A.C. Mechanical pump
2. S.U. Electrical pump
3. Electromagnet pump
4. Combined pump (fuel pump with a vacuum pump)

Mechanical Pump: The mechanically operated diaphragm type fuel pump is operated by an eccentric mounted on the camshaft of the engine. The pump consists of a spring loaded flexible diaphragm actuated by a rocker arm. The rocker arm is actuated by the eccentric. Spring loaded valves are there in the inlet and outlet of the pump. These valves ensure flow of fuel in the proper direction.

As the rocker arm is moved by the eccentric, the diaphragm is pulled down against the spring force. This movement causes a partial vacuum in the pump chamber. Now the delivery valve remains closed and the suction valve opens. This admits fuel into the pump chamber. At the maximum position of the eccentric, the diaphragm is flexed to the maximum extent after this further rotation of the eccentric will release the rocker arm. Now the rocker arm will simply follow eccentric by the action of the return spring. The diaphragm spring will now push the diaphragm upwards and the force the fuel to flow out, opening the delivery valve, into the delivery tube. Now the suction valve remains closed.

In this pump, the downward movement is caused by the rocker arm, while the delivery stroke is achieved by the force of the diaphragm spring. The diaphragm spring is so designed that the fuel pressure is suitable balanced by the buoyancy of the float system of the carburetor. As such, when deliver fuel to the carburetor. In this case, the rocker arm simply continues to rock while the diaphragm remains at or near its lowest travel. However, as the carburetor uses fuel, the needle valve opens to admit fuel

into the float bowl. Now the diaphragm moves downward by the rocker action and sucks the fuel to deliver back the same when required. This self regulating feature helps the pump to deliver the correct quantity of fuel at all operating conditions.

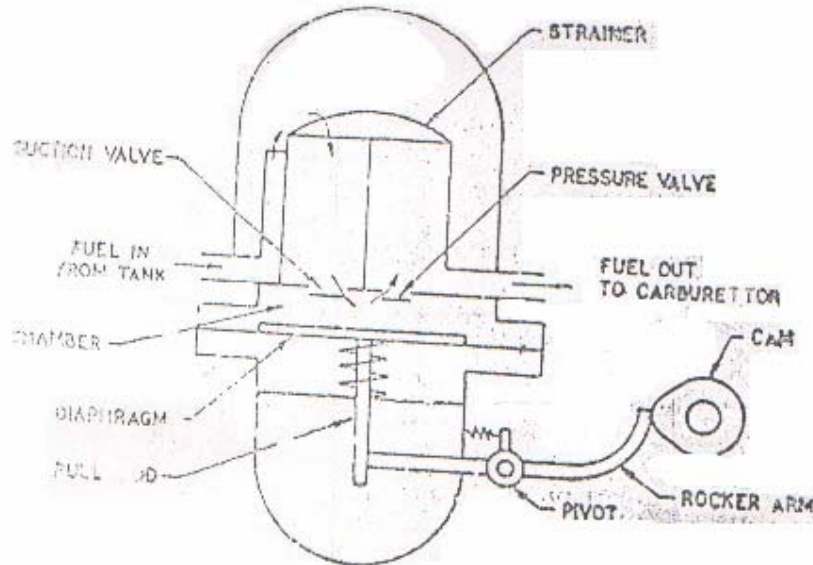

A.C. mechanical fuel pump.

Electrical Fuel Pump: The electrical fuel pump is mounted in the engine compartment. A pump with electrically operated diaphragm is the SU Horizontal pump. The pump contains a flexible diaphragm that is operated by an electromagnet instead of the mechanical system. The diaphragm consists of a number of layers of impregnated fine gut fabric. The middle of the diaphragm is clamped to an armature. A rod attached to the middle of the diaphragm passes through the center hole in the electromagnet. All the other end of the rod electrical contact points are there. There is a return spring which keeps the diaphragm in position.

When the electromagnet is connected to the battery, it produces the armature compressing the return spring and there by flexes the diaphragm. This produces vacuum in the fuel chamber. Fuel from the fuel tank enters the fuel chamber through the inlet valve. Then, as the rod attached to the diaphragm reaches its limit of travel it opens the set of electrical contact points. This disconnects the electromagnet from the battery. The compressed return spring therefore pushes the armature and the diaphragm. This forces the fuel from the fuel chamber through the outlet valve to the carburetor. As the diaphragm flexes back to its original position and the rod attached to it reaches the limit of its travel, it closes the electrical contacts. Now the electromagnet is again energized and tries to pull the armature and diaphragm. This series of actions is repeated as long as the ignition switch is turned on.

If the float chamber is so full as to close the needle valve, the pump diaphragm will remain at rest in the flexed position with the electrical circuit broken, until further delivery is required. The float mechanism of the carburetor must be method with the return spring of the pump so that flooding of the carburetor cannot occur.

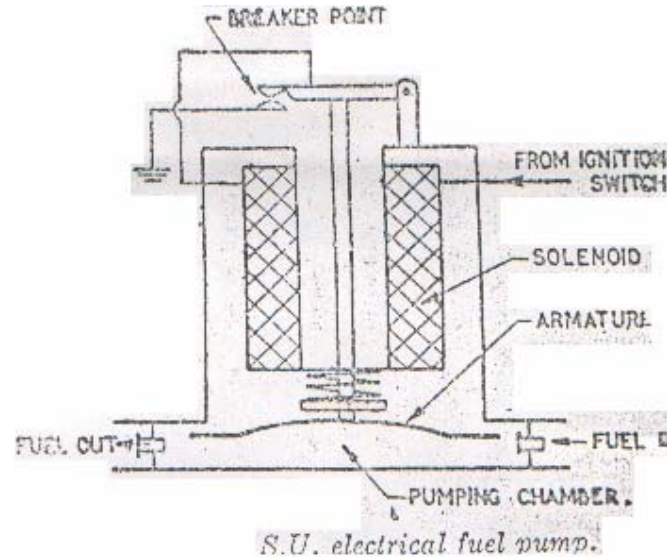

3.4 Requirements of an automobile Carburetor:

The carburetor is a device for atomizing and vaporizing the fuel and mixing it with the air in varying proportions to suit the changing conditions of spark ignition engines. The air fuel mixture so obtained from the carburetor is called the combustible mixture. The process of mixing the gasoline fuel with air to obtain the combustible mixture is called carburetion.

Vaporization is the change of state of the fuel from liquid to vapour. Atomization is the mechanical breaking up of the liquid fuel into small particles, so that every particle of the fuel is surrounded by air. In order to produce very quick vaporization of the liquid fuel, it is sprayed into the air passing through the carburetor. Spraying of the liquid turns it into many fine particles, so that the vaporization occurs almost instantly.

The carburetor supplies the air-fuel mixture of varying proportions to suit the changing conditions of the engine. The mixture must be rich for starting, accelerating and high speed operation. The mixture should be lean for operation at intermediate speed with a warm engine. The theoretically perfect mixture of air and gasoline contains 15 parts of air and 1 part of gasoline by weight.

3.5 Air Fuel ratio:

The Carburetor must supply the air-fuel mixture of varying proportions to suit the different operating requirements. The mixture must be rich for starting and must be relatively lean for idling and intermediate speeds. The air-fuel ratio for different speeds of a car can be as follows.

For starting of the car, the air-fuel ratio is 9:1. It is called rich mixture.

For idling condition, the air-fuel ratio lies about 12:1. It is called lean mixture.

For intermediate speeds between 35 to 105 km/hour, the air-fuel ratio varies further leans out to 15:1.

But at higher speeds from 120 to 150 km/hour, with a wide open throttle, the mixture is again enriched to about 13:1.

For acceleration at any speed the throttle is suddenly opened which causes a momentary enrichment of the mixture.

Two examples of acceleration are shown by dotted lines, one at 25 km/hour and the other at 45 km/hour.

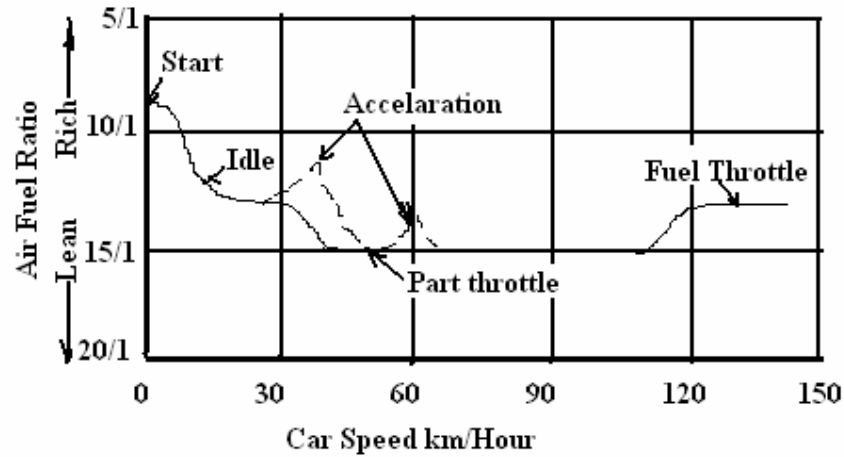

Air fuel ratio for different speeds of a car

3.6 Types of carburetors and their arrangements

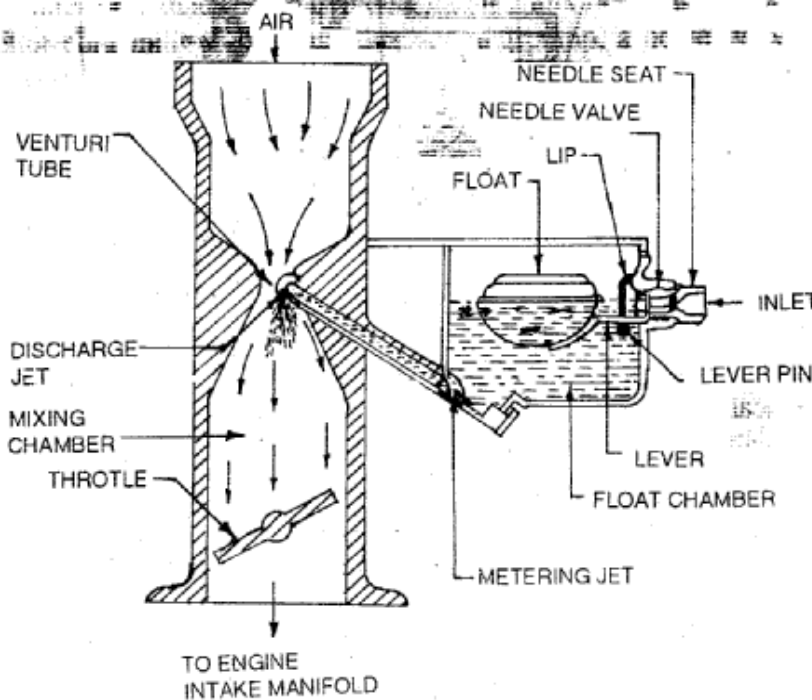

Carburetors used in S.I. Engines may be up draught, down draught and side draught. This classification is based on the direction of air flow into the carburetor and air fuel mixture flow at the carburetor outlet to the inlet manifold.

In down draught carburetor, the air enters top of the carburetor and leaves at the bottom. In side draught carburetor, the air enters the top of the carburetor and leaves at the side. In up draught carburetor the air enters the bottom or side of the carburetor and leaves at the top. In semi down draught carburetor the direction of air flow is from top to bottom.

Side draught carburetors are used on Hero Honda, Kawasaki Bajaj and Sunny.

Most passenger cars are used down draught carburetors.

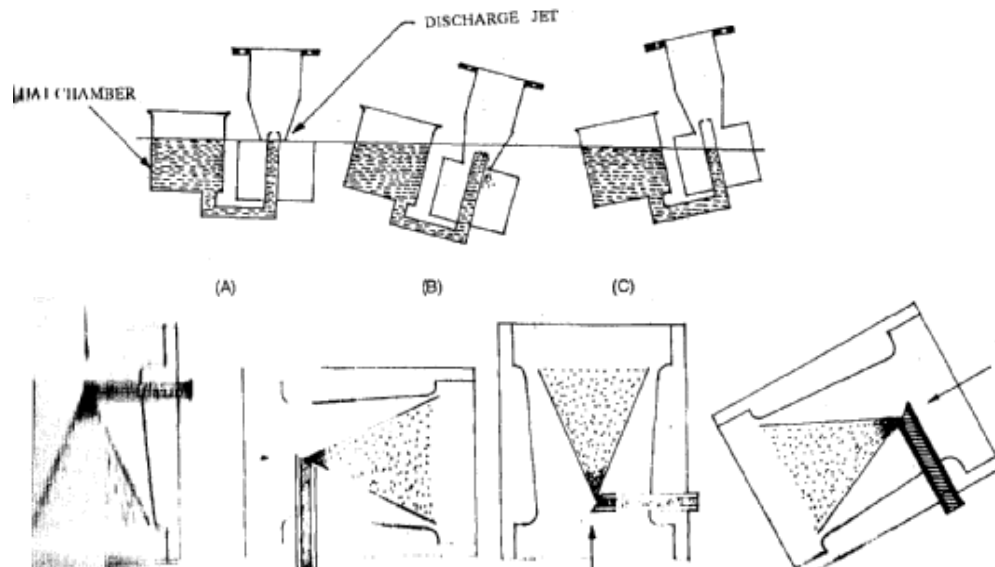

3.7 Carter Carburetor

It is a down draught type carburetor. It is typical in construction like Zenith Carburetor. It consists of the following circuit.

1. Float circuit
2. Starting circuit
3. Idle and low speed circuit
4. Port throttle circuit
5. Full throttle circuit
6. Acceleration pump circuit.

The float circuit controls the supply of the fuel from the fuel filter into the float chamber. The float is pivoted at a side of the chamber and operates a needle valve to close and open the passage through which the fuel enters the chamber.

At the time of starting the cold engine, the choke valve is operated to close the air supply. The choke valve is mounted eccentrically, due to which it opens automatically after the engine has started.

The whole suction is applied on the main nozzle which delivers fuel. The air supply being quite small, the air fuel mixture becomes rich for starting. A rich mixture is required in small quantity for idling. The throttle valve is almost closed during the idling. Thus the engine suction is applied at the idle port which supplied the required air fuel mixture. For low speed the throttle valve is little opened. The main nozzle also begins to supply the fuel. The throttle valve is further opened for increasing the speed. At this stage, the throttle valve is partly opened and the fuel is supplied by the main nozzle only.

When the throttle valve is fully opened the maximum amount of air passes through the venturi and a higher rate of fuel supply is required. This is achieved by means of the metering rod. When the acceleration pedal is depressed, the throttle valve is fully opened and simultaneously the metering rod is lifted up in the jet providing larger area for fuel supply. This amount of air fuel mixture is supplied for high speed.

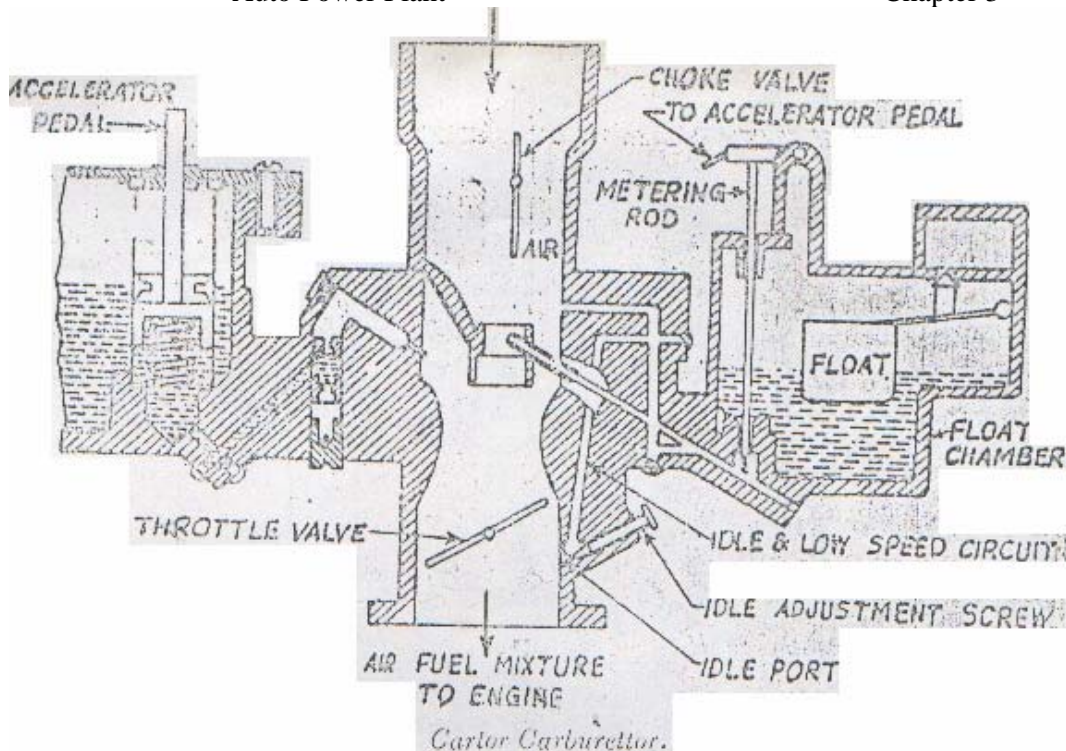

Zenith Carburetor

The zenith carburetor is one of the most popular carburetors. It is found in many models as

1. Zenith negative
2. Stormberg
3. DBV
4. New Zenith
5. NV type
6. W type
7. WIA type
8. Case emission type.

The current model of zenith carburetor contains economy device and accelerating pump. The old type of float chamber the fuel enters from the bottom and the float is controlled by toggle lever. This system is entirely eliminated in recent years. There are 3 jets – main jet, compensating jet and idling jet in the carburetor. This compensating jet is around the main jet. The choke valve is used for starting. For idling and slow speed running, the air enters through the holes A and B, mixes with the fuel in idling passage and the mixture passes to the idling jet. A separate knob is provided for idle adjustment, which controls the opening B to supply the mixture. When the throttle valve is opened, the main jet comes into action, along with the idling jet. On further opening the throttle valve, the whole suction is applied on the main and compensating jet, the idling jet is cut off. The compensating jet takes care to maintain correct air fuel ratio at different speeds.

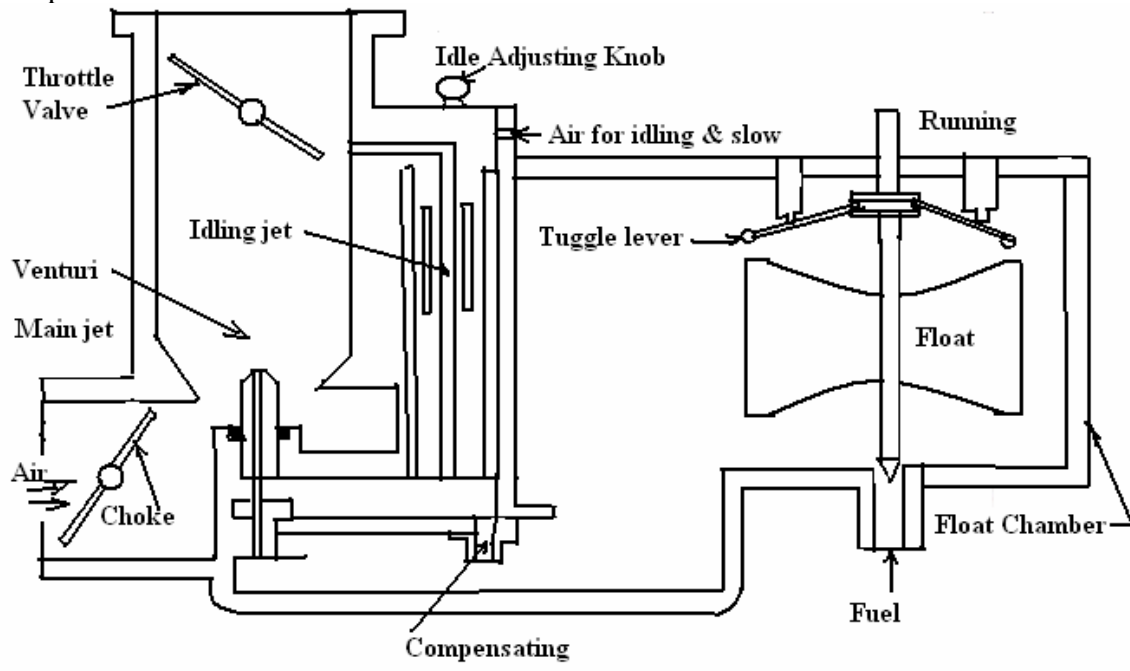

Zenith Carburetor mostly used in British Cars

atmospheric pressure. Thus, the piston at any instant depends upon the balance of its own weight against the vacuum force. As the weight of the piston is constant the vacuum also remains constant. The jet can move broadly up and down with respect to the tapered needle by an adjusting screw fitted at the bottom of the screw. This is done for adjusting the mixture strength. There is no separate idling or slow speed system and no accelerating pump. This type of carburetor is the rapid response during accelerating and hence it is fitted with racing cars and in most of the scooters and motorcycles.

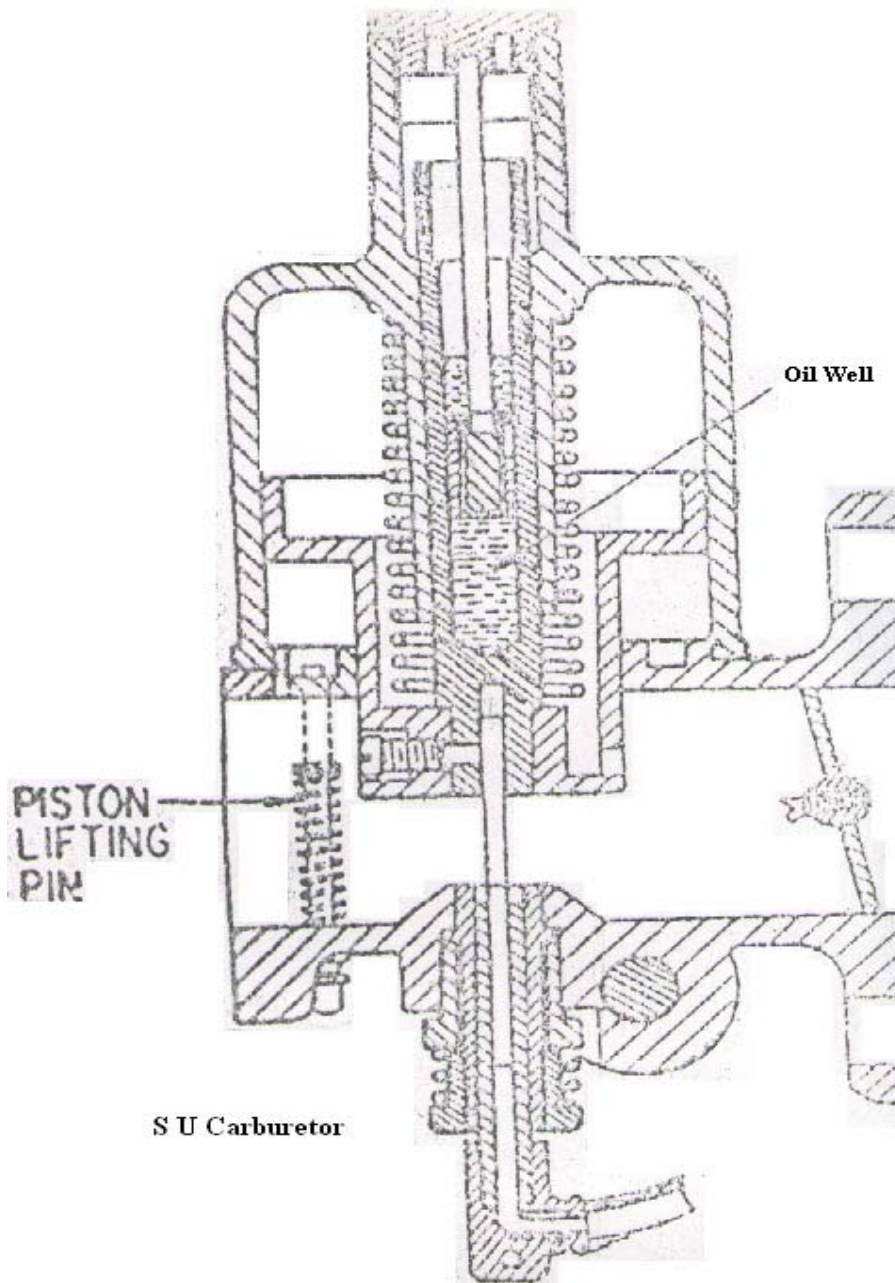

3.8 Petrol Injection system in modern vehicles

Petrol injection system is used in modern cars where a single carburetor is used to deliver air fuel mixture into multi cylinder engine. It is likely that some of the cylinders may not get regular supply of the mixture. The use of petrol injection system overcomes these difficulties. It ensures unrestricted fuel supply and controls it at all times of the

engine operation. Petrol injection gives both higher power and low specific fuel consumption. But it has some disadvantage also like higher initial cost and maintenance cost, complicated design and difficult in operation.

Construction lay out of petrol injection system

The petrol injection fuel supply requires following main parts.

1. Petrol injection pump
2. Acceleration pump
3. Metering distributor
4. Injection nozzle.

It uses an injection pump to each cylinder, the pump being actuated through rockers by a camshaft rotating at half the engine speed. The accelerator pedal controls a butterfly throttle which regulates the air supply to the inlet manifold and at the same time varies the return stop of each pump plunger to control its stroke and thus the rate of fuel delivery. This is done through an ingenious "3 dimensional cam" which adjusts the pivot points of the pump rockers. The same cam is also influenced by a governor device in accordance with engine speed to maintain correct mixture over the entire petrol directly into the inlet manifold for starting purposes, operating only whilst the starter motor is energized.

3.9 Working principle of supercharger

The process of supplying to the engine the air fuel mixture above the atmospheric pressure is called super charging. A super charger increases the pressure of the air fuel mixture from the carburetor before it enters the engine.

Superchargers

A supercharger is a device which increases the pressure of the air fuel mixture from the carburetor before it enters the engine. It is connected between the carburetor and the cylinder in the way of intake manifold. It is usually driven by the engine through suitable gears and shafts. There are 3 types of superchargers.

1. Centrifugal type
2. Vane type
3. Roots air blower type.

Centrifugal type supercharger

It consists of an impeller which rotates at a very high speed, about 10000 RPM. The air fuel mixture enters the impeller at the centre and after passing through the impeller and diffuser vanes goes out of the casing to the engine cylinder. Duct to high speed of the impeller is forced into the cylinder at a higher pressure.

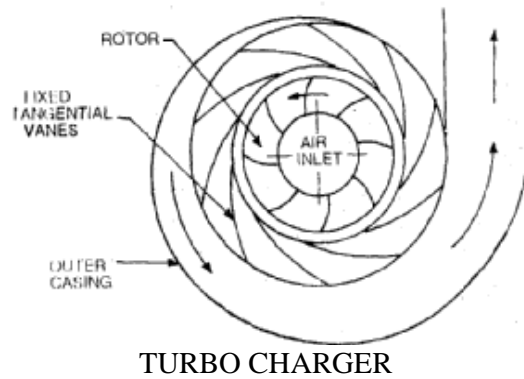

Scavenging process

At the end of the expansion stroke, the combustion chambers of a two stroke engine is left full of products of combustion. This is because unlike 4 stroke engines there is no exhaust stroke available to clear the cylinder of burnt gases. The process of clearing the cylinder, after the expansion stroke, is called scavenging process. This must be completed in a very short duration available between the end of the expansion stroke and start of the charging process.

Crankcase scavenging

The most obvious and cheapest in initial cost is the use of crankcase for compressing the incoming air and then transferring it to the cylinder through a transfer port.

Summary

- ✿ A petrol engine uses petrol as the fuel
- ✿ The fuel tank gives a beautiful look to the two wheeler.
- ✿ The capacity of the engine does not imply the volume of the fuel tank but the volume of the cylinder.
- ✿ The supply of rich or lean air fuel mixture is done by the carburetor.
- ✿ Idle air fuel mixture gives the engine to run idle when the vehicle stops for a less time.
- ✿ Idle condition is maintained at the position when the runs in neutral gear position.
- ✿ Rich air fuel ratio is required when the vehicle is overcoming an uproad or carrying heavy loads.

Exercise

1. Draw a neat line diagram of petrol engine fuel system.
2. Explain the constructional details of fuel tank, fuel lines.
3. Explain the construction and working of fuel pump used in a petrol engine.
4. What are the requirements of an automobile carburetor
5. Draw the graph between the speed and air fuel ration for a petrol engine.
6. Explain the air fuel ratio for different conditions.
7. Explain the types of carburetor according to direction of air flow.
8. With the help of a neat sketch explain the construction and working of a Carter Carburettor.
9. Write the constructional details of a Zenith Carburetor.
10. How a Solex carburetor work?
11. Explain the constructional details of a S.U, Carburetor.
12. Discuss about the petrol injection system in a Modern Vehicles.
13. Explain the working principle of a) a Super charger and b) A Scavenger.

4. Diesel engines

In two stroke diesel engines, all the work i.e. intake, compression, power and exhaust are completed in two strokes of the piston or one complete revolution of the crankshaft. In two stroke cycle engines there is one working stroke in two revolutions of the crankshaft or in a cycle of two strokes of the piston and these are usually called the upward and downward strokes.

4.1 Working principle of 2 stroke and 4 stroke diesel engines

2 stroke diesel engine:

In two stroke diesel engine both the ports i.e. intake and exhaust are made in the cylinder and the piston used is also dome type. When the piston travels down, the exhaust port gets uncovered by the piston. As such the burnt gases escape through this port. When the piston travel a little more down, the inlet port also gets uncovered by piston from where the fresh air finds its way in the cylinder.

Upward stroke: When the piston starts traveling up from BDC to TDC, it closes the inlet and exhaust ports and the air which is trapped in the cylinder starts getting compressed. Due to high compression ratio the temperature and pressure of air rises very high. As soon as the piston reaches near TDC, diesel fuel is sprayed in fine atomized form to the highly compressed gases.

Downward stroke: As stated above due to spraying of atomized diesel on highly compressed air, there is spontaneous combustion gases expand rapidly causing piston to travel from TDC to BDC giving us power stroke. As soon as the piston reaches near BDC the exhaust gases escape out through exhaust port uncovered by the piston thereby relieving piston top of thrust caused by expanded gases. In the mean time, the inlet port also opens causing air to come in the cylinder. This air also helps in sweeping out exhaust gases and thus the cycle continues.

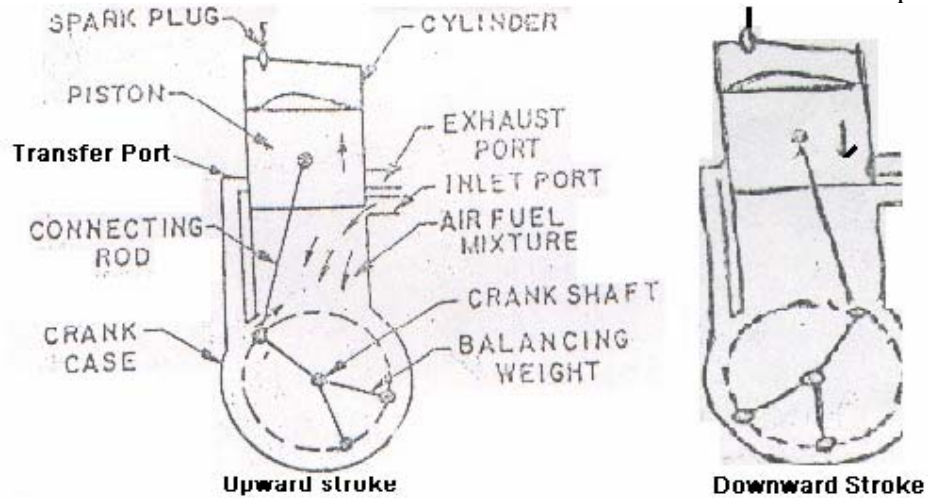

Working of four stroke diesel engine:

The working of a 4 stroke compression ignition engine consists of the following processes

1. Suction Stroke
 2. Compression stroke
 3. Power or working stroke
 4. Exhaust stroke
- 1 **Suction Stroke:** When the piston moves from TDC to BDC the inlet valve opens and due to the downward movement of piston a partial vacuum is created in the cylinder above the piston. Due to this partial vacuum air is sucked in at the end of stroke the inlet valve closes.
 - 2 **Compression Stroke:** When the piston starts moving from BDC to TDC the air which has been trapped in the cylinder starts getting compressed, when the piston reaches near TDC, the trapped air gets so compressed that its temperature reaches between 500°C to 650°C . this higher increase in temperature is because of higher compression ratio, in this stroke both valves remain closed.
 - 3 **Power Stroke:** At the end of compression stroke diesel oil is sprayed in fine atomized form to the burning hot air which has attained temperature of approximately 500° to 650°C here we would like to mention that self ignition temperature of diesel fuel at atmospheric pressure is 350°C to 450°C as such atomized fuel in hot air gets ignited in more or less rapid explosion making gases to expand. We have earlier studied that piston is the only moving part in the cylinder.
 - 4 **Exhaust Stroke:** In this stroke, the exhaust valve opens and due to moving of piston from BDC to TDC, the burnt gases are pushed out. The inlet valve opens in suction stroke but as a matter of fact it opens 10° to 22° before TDC in exhaust stroke. So that valve is fully open when piston starts moving down and enough time is given for air to get it. The inlet valve remains open in compression stroke 20° to 30° after BDC. This once again is to allow air which was coming to cylinder to cylinder with great velocity to fill cylinder completely.

4.7 Types of diesel engine combustion chambers

The Various types of diesel engine combustion chambers are

1. Direct injection combustion chamber
2. Pre combustion chamber
3. Turbulence combustion chamber

1. **Direct injection combustion chamber:** It is used in medium and high speed engines. The combustion chamber is made like a groove inside the top of the piston. The injection is filled at the centre of the cylinder head so that it injects the fuel in the combustion chamber. Leyland buses are used this type of chambers.
2. **Pre combustion Chamber:** It is usually used in high speed engines. There are two combustion chambers – one is auxiliary combustion chamber and other is main combustion chamber. This auxiliary chamber is smaller in size than the main combustion chamber and is called pre combustion chamber where it partly burns. This partly burnt fuel goes through a small orifice in the main combustion chamber, where the complete combustion takes place. The turbulence created in combustion chamber helps to ignite the fuel completely.
3. **Swirl combustion or Turbulence combustion chamber:** It is of circular motion which is given to the incoming air during the suction stroke. In the swirl combustion the air is given a swirl while coming in the cylinder. The fuel is injected in this swirled air so that mixing and burning of fuel takes place completely.

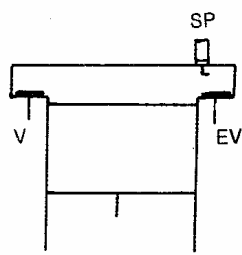

T-shape combustion chamber
(Low compression ratio).

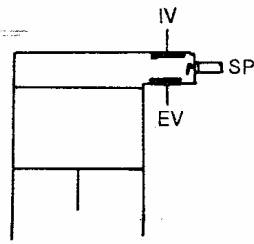

(a) Low compression ratio.

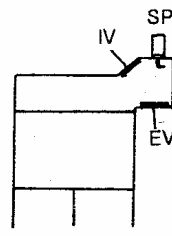

(b) High compression ratio.

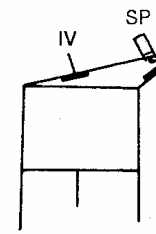

(c) More turbulence

F-shape combustion chambers.

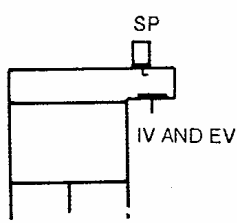

(a) Low compression ratio.

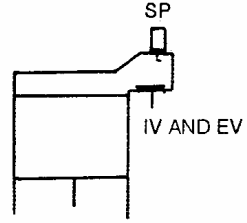

(b) High compression ratio.

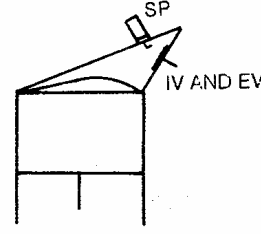

(c) More turbulence

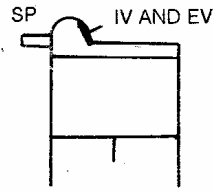

(d) More turbulence

L-shape combustion chamber.

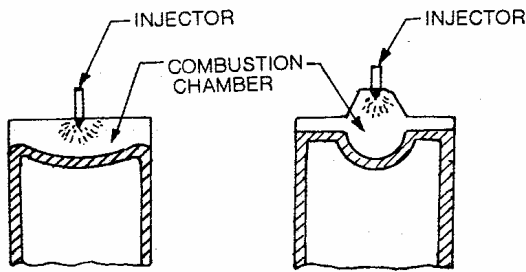

(a) (b)
Open combustion chamber.

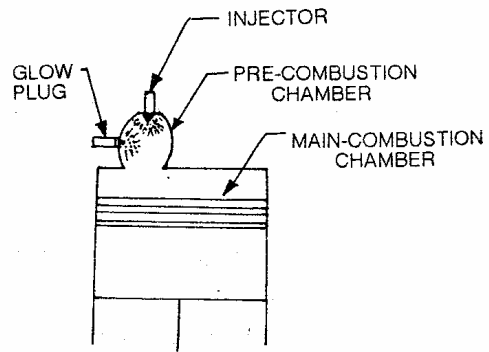

Pre-combustion chamber.

Summary

1. There are upward stroke and downward stroke in two stroke engines
2. Two stroke engines are very light and are less duty.
3. Maintenance of two stroke engines is very easy compared to four stroke engines.
4. Only ports are used in two stroke engines.
5. Four stroke engines comprises of suction, compression, power or expansion and exhaust strokes.
6. Four stroke engines contain valves.
7. The valves of a four stroke engine are operated by valve operating mechanism.
8. Overhead mechanism, side valve mechanism are most commonly used valve mechanisms in four stroke engines.
9. The four stroke engines are lubricated by splash or pressure lubrication system.
10. The power developed by a four stroke engine is more compared to a two stroke engine.
11. A diesel engine produces more power output than a petrol engine of same capacity.
12. The diagram which shows the valve opening and closing time of an engine is called the valve timing diagram.

Exercise

1. Enumerate the working of a two stroke diesel engine with the help of neat sketches.
2. Discuss the advantages and limitations of a diesel engine over a petrol engine.
3. A diesel engine requires more compression ratio. Explain.
4. The power output of a diesel engine is more than that of a petrol engine. Explain
5. Briefly explain the valve timing diagram of a diesel engine with the help of a neat sketch.
6. Discuss the various types of combustion chambers

5. DIESEL ENGINE (FUEL FEED SYSTEM)

To run an engine, the fuel from the tank must reach by some means to the engine cylinder. In diesel engine, the fuel is injected into the engine cylinder by an injector. The fuel burns in the cylinder and during the exhaust stroke, the burned gases leave the cylinder passing through the exhaust pipe and silencer.

5.1 Line diagram of diesel engine fuel system.

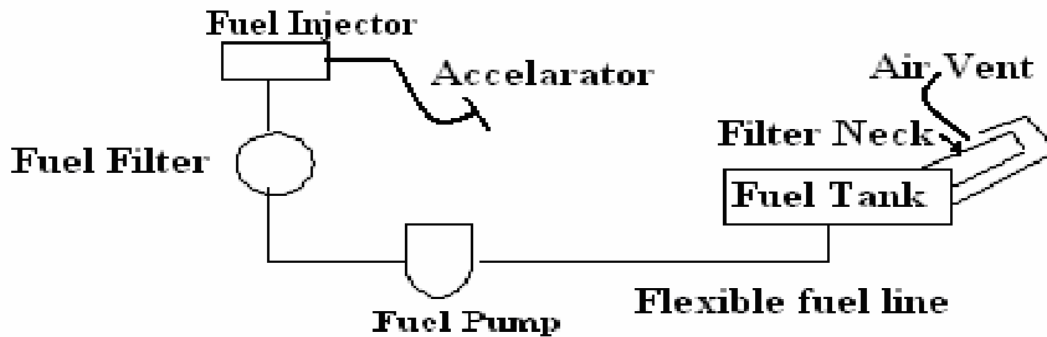

5.3 Requirements of fuel feed system:

In the engine to develop full power and operate efficiently its fuel system must do the following:-

Meter (measure):- The fuel injection system must measure the fuel supplied to the engine very accurately. Since fuel requirements vary greatly from low to high engine speed. Fuel is measured within the injection pump or injector by measuring it as it fills the pumping chamber or as it leaves the pumping element.

Time: - The timing of fuel injected into the cylinder is very important during engine starting, full load and high speed operation. Diesel engines start best when fuel is injected at or very close to Top Dead Center, since it is at this point that air in the chamber is the hottest. After the engine is started and running at high speed, the injection timing may have to be advanced to compensate for injection lag, ignition lag, and other factors that influence combustion within the engine cylinder.

Pressure: - The fuel system must pressurize the fuel to open the injection nozzle or the pressure required to open the nozzle. Some pressure is required to inject the fuel into the combustion chamber to offset the pressure of compression, which may be 350 to 450 psi (25 to 32 kg/cm²).

Atomize: - The fuel must be atomized when it is injected into the combustion chamber. Since in atomized fuel will not burn easily. The degree of atomization required will vary from engine to engine depending on the combustion chamber design.

Distributor: - Closely related to timing the distribution of fuel must be accurate and according to the engines firing order distribution pumps deliver fuel to each pump outlet in succession and the lines are hooked to the cylinder in the correct firing order, much like a distributor used on a gas engine.

Control, start and stop injection: - Injection of fuel must start quickly and end quickly. Any delay in beginning will alter the pump to engine timing, causing hard starting and poor running engines.

5.4 Methods of fuel injection: There are two methods of fuel injection in compression ignition engines.

1. Air blast injection 2. Airless or solid injection.

Air blast injection: This method was originally used in large stationary and marine engines. But it is now obsolete. In this method the air is first compressed to a very high pressure. A blast of this air is then injected carrying the fuel along with it into the cylinder. The rate of fuel injection is controlled by varying the pressure of the air. The high pressure air requires multistage compressor so as to keep the air bottles charged. The fuel ignition by the high temperature of the air caused by the high compression.

Airless or solid injection: - In this method the fuel under high pressure is directly injected into the combustion chamber. It burns due to the heat of compression of the air. This method requires a fuel pump to deliver the fuel at the high pressure. This method is used for all types of small and big diesel engines. It can be divided into two systems.

a. Individual pump system. b. Common rail system.

- a. Individual pump system: In this system, each cylinder has its individual high pressure pump and a metering unit. It is quite compact method and involves higher cost.
- b. Common rail System: In this system, the fuel is pumped by a multi cylinder pump into a common rail, the pressure in this rail is controlled by relief valve. A metered quantity of fuel is supplied to each cylinder from the common rail. The airless injection in comparison to air blast injection, is simple in construction, light in weight and cheap. The fuel is atomized properly. It is quite suitable for engine of higher output. But it receives higher accuracy in manufacturing the pump barrel and fuel injection plunger.

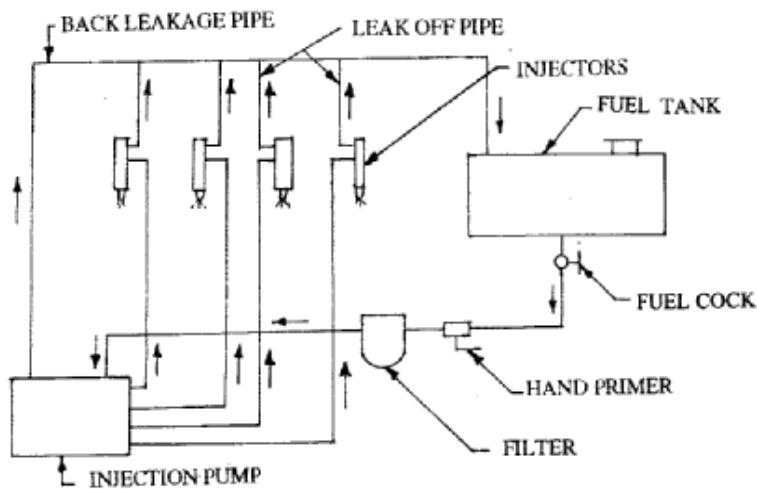
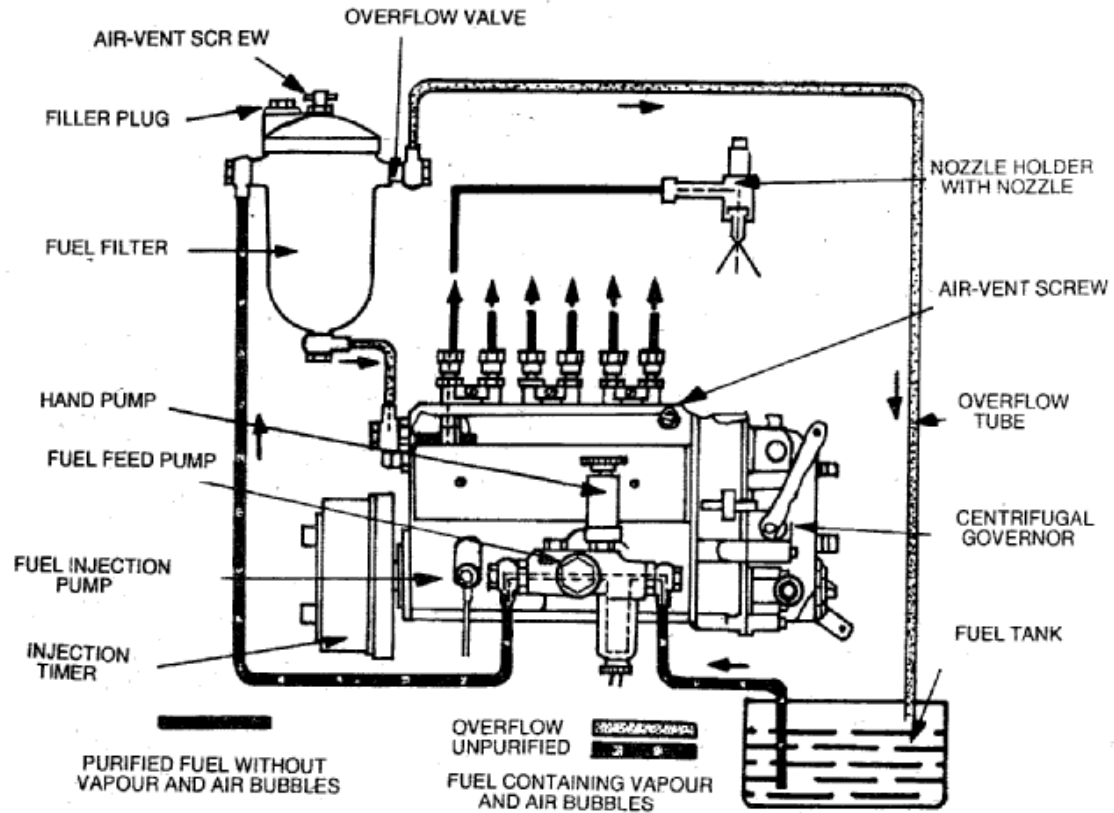

Diesel fuel feed system: The fuel system of a diesel engine consists of the following:-

1. Air cleaner
2. Fuel tank
3. fuel filter
4. injection pump
5. injector
6. fuel lines

7. fuel gauge

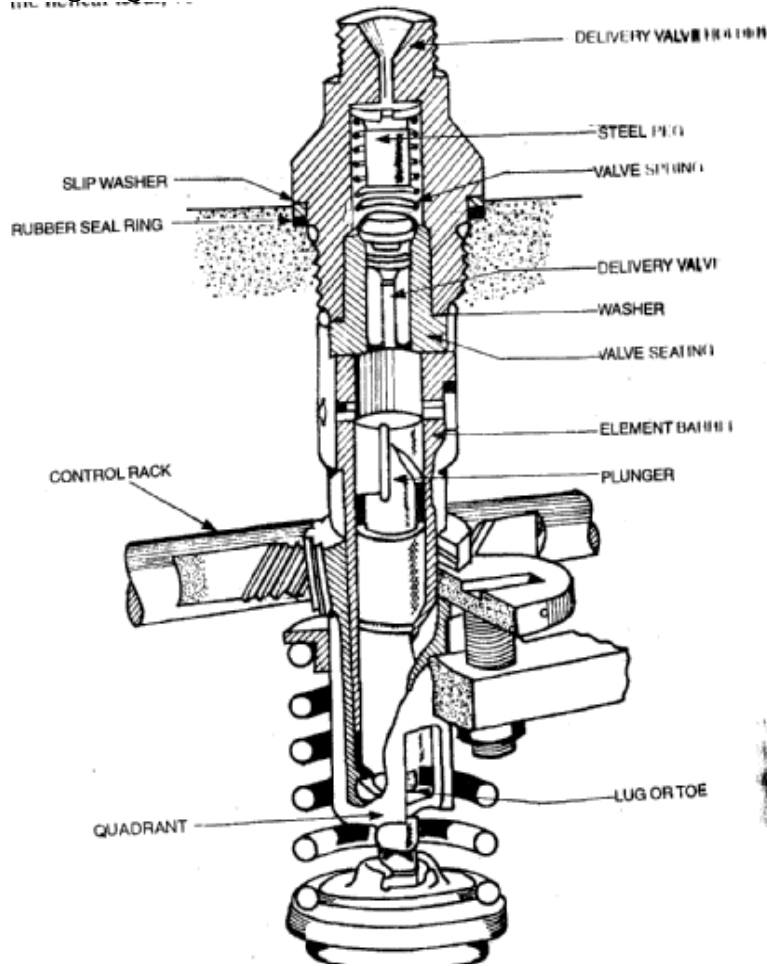

Fuel Injection Pump

5.5 Fuel injection pump construction and working:-

The single plunger diesel fuel injection pump is distinguished from the conventional in line pumps of the PE and PF series by having only one plunger and barrel assembly, common to all fuel outlets of the pump where as each fuel outlet of an inline pump is served by its individual plunger and barrel assembly. The single plunger injection pump described here in features a unique hydraulic governing system which has no rotating mechanical parts and which provides extremely accurate fuel quality control and fast response to variations in fuel demand resulting in very close regulation.

A single plunger by reciprocating action pressurizes the fuel and feeds it into two distinctly separated circuits, primarily at high pressure to the nozzle and holds assemblies and secondly into an auxiliary circuit for the function of governing the fuel quantity delivered to the engine.

By simultaneous rotation of the plunger, the pressurized fuel quantity delivered to the engine from the primary circuit is distributed to the individual high pressure outlets. All accessory units such as governor, fuel supply pump and the automatic timing device, normally attached to the outside of an

inline pump are wholly integrated into the single plunger pump to reduce bulk and weight.

The single plunger injection pump can be mounted in any position. In operation, its interior is completely filled with diesel fuel under slight pressure in order to prevent intrusion of air and dust and also to prevent rust formation caused by condensation. Excess fuel is re circulated within the pump to provide adequate cooling and lubrication.

Fuel Injector (Atomizer):-

The purpose of the fuel injector is to inject a small volume of fuel in a fine spray and to assist in bringing each droplet into contact with sufficient oxygen to give quick and complete combustion.

C.A.V. fuel injector consists of a needle valve which is pressed on its seating in the nozzle by a plunger or spindle. A compression spring controls the pressure upon the plunger by which the needle valve opens. A nozzle is attached to the body of the injector by a cap nut. The fuel enters the nozzle through drillings in the injector body. The fuel may pass from a gallery down the sides of the lower parts of the needle valve. The body or the nozzle holder provides access for the fuel and an outlet for the fuel that leaves into the area occupied by the spring.

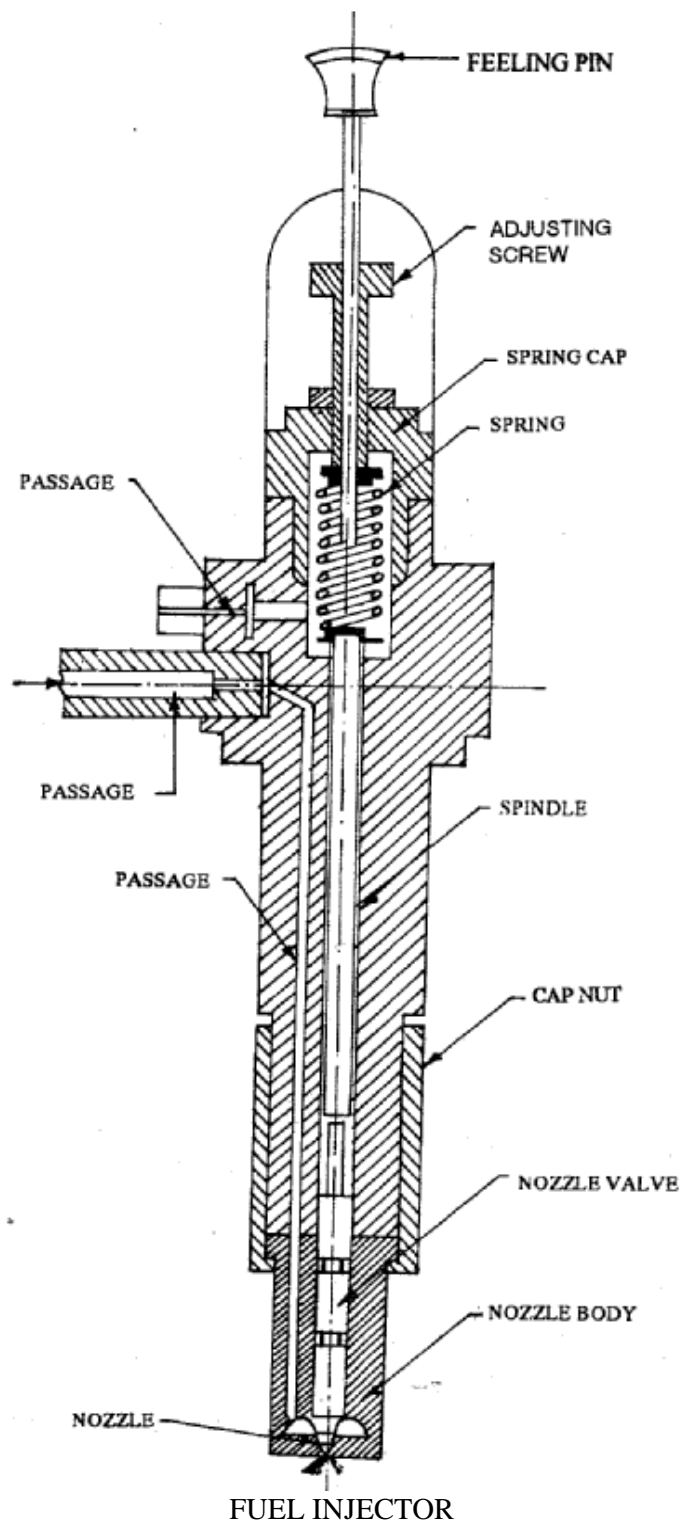

Fuel injection nozzle:-

The performance of a modern high speed oil engine depends largely upon the proper functioning of its fuel injection system. The engine be not only provide with fuel in quantities exactly timed and proportional to the amount of work it is received to do.

The fraction of the nozzle, which is held in position in the cylinder head by the nozzle holder. The nozzle may have to deal with many hundreds of fuel charges per minute, with widely varying conditions of pressure and temperature, the uneven precision necessary in the production of these parts will be appreciated.

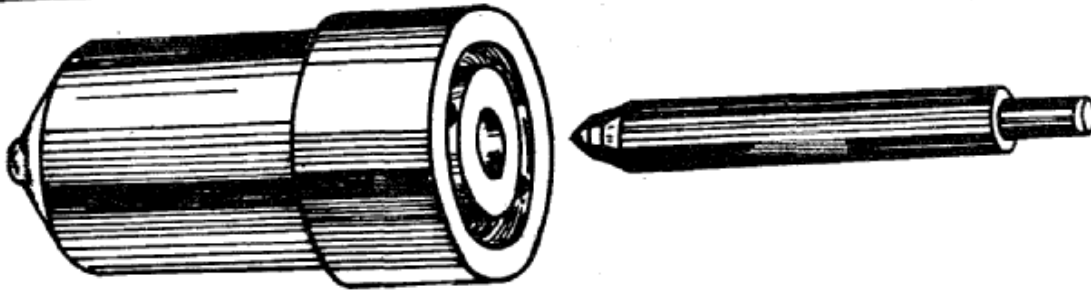

Types of nozzles:-

- a. Single hole nozzle
- b. Multi hole nozzle
- c. Long stem nozzle
- d. Pintle nozzle
- e. Delay nozzle
- f. Pintaux nozzle

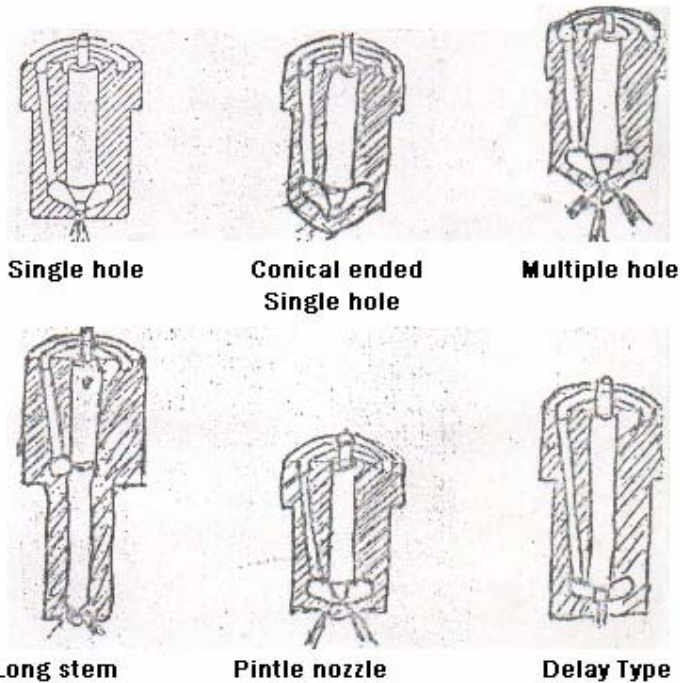

Types of Injection Nozzles

- a. Single hole nozzle: - The single hole nozzle has one hole drilled centrally through its body which is closed by the nozzle valve. The hole can be of any diameter from 0.2 mm upwards. The single hole is bored at an angle to the vertical center line of the valve as required.
- b. Multi hole nozzle: - This nozzle can have a varying number of holes drilled in the bulbous end under the valve seating. Their actual

number, size and disposition being dependent upon the requirements of the engine concerned.

- c. Long stem nozzle: - For direct injection engines where, owing to a limited space between the valves in the cylinder head it is not possible to provide adequate cooling for the standard short stem nozzle, an alternative form of nozzle with a small diameter extension has been developed.
- d. Pintle nozzle: - The pintle nozzle is designed for use in the engine combustion chambers of the air cell, swirl chamber or pre-combustion type, the valve stem is extended to form a pin or pintle which produces through the mouth of the nozzle body.
- e. Delay nozzle: - The Delay nozzle is a development of pintle type, having an auxiliary spray hole to assist easy starting under cold conditions. At engine starting speeds the nozzle valve is not lifted sufficiently to clear the pin hole and the fuel is discharged through auxiliary hole. At normal running speeds, however when pressures in the fuel system is higher, the nozzle valve is withdrawn from the pintle hole allowing the bulk of the fuel to be discharged through it.

5.6 Phasing of injection pump:-

The plunger has to be phased so that they start delivery of fuel to cylinder at specific angle of crank shaft. This is accomplished by a mounting the injection pump on test much and nothing the angle of delivery on its flywheel. This is adjusted by the tappets or by adding or removing hardened shims which are available in various thickness from 0.5 to 1.4 mm in stages of 0.1mm.

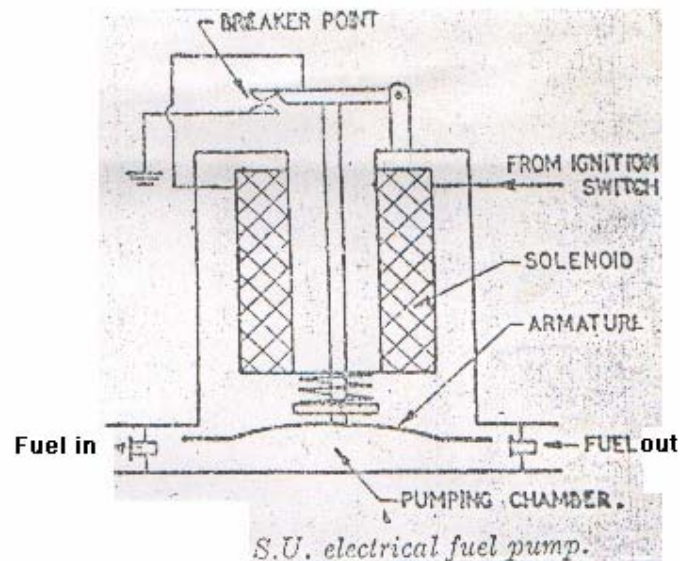

Calibration of injection pump:-

All the plungers in a given pump should give equal quantity of fuel at any RPM. The quantity is adjusted by loosening the clamping screw of the toothed quadrant and rotating the plunger by turning the control sleeve by inserting a needle in hole.

Governors: - All the diesel engines are equipped with governors to ensure that engine does not pick up speed when there is no load on it as the speed of the engine is dependent on the quantity of fuel injected. The governor has also to supply enough fuel when engine is loaded so that the vehicle speed does not drop down.

Types of governors:

1. Mechanical Governor
2. Pneumatic Governor
3. Combined (Mechanical and Pneumatic) governor
4. Hydraulic governor.

5.7 Construction and working of Mechanical and Pneumatic Governors

Mechanical governors are fitted to large engines on our extension of the pump camshaft and works on centrifugal force principle. In this case 2 weights are hinged to the camshaft pump. Both weights are hinged with lever which in turn is connected to lever with the help of coupling pin, when we increase the speed of engine through an accelerator, the camshaft revolves at high speed, the weights fly out due to centrifugal force taking along with it the control rod, to stop position due to linkages. These weights are fixed to the cam shaft with the help of spring placed in them.

These springs do not allow the weights to fly out uncontrolled. As such the control rod does not come to stop position, but maintained at intermediate balanced position. As a matter of fact, the springs fitted in the weight counter balance the centrifugal force produced by fast moving camshaft.

Pneumatic Governor: The pneumatic governor covers the complete range of engine speed i.e. from idling speed to maximum speed.

The complete governor consists of 1. Venturi air flow control unit 2. Diaphragm unit.

Venturi air flow control unit is fixed in inlet manifold under the air cleaner. In this unit a small venture is fixed by the side of butterfly valve, so that quantity of air can be increased or decreased as delivered. The butterfly valve is linked to the accelerator pedal with suitable linkage. A maximum and idle stop adjustment provided on the venture unit.

Diaphragm unit is fitted at the end of injection pump over the opening of control rod. This consists of 2 chambers separated from each other by leather or rubberized diaphragm. The outer chamber is called vacuum chamber and is connected to venturi unit while other unit is open to atmospheric pressure. At the end corner of vacuum chamber is fitted a spring which keeps the diaphragm and control rod towards full load position. The diaphragm is linked to the control rod with the help of a pin and is kept in fuel load position with the help of diaphragm spring. But as soon as the engine starts, vacuum produced in the venturi acts on diaphragm thus pulling it outward, taking control rod along with it. As the speed of engine increases or decreases as such the diaphragm is pulled out and pushed in and speed is kept under control. To stop the engine a stop lever is also placed in the atmospheric chamber which when pulled pushes the diaphragm along with control rod to stop position.

Summary

- Diesel is extracted from its ore called petroleum.
- The self ignition temperature of Diesel fuel is less than that of the petrol. That is the reason why diesel is ignited by the heat of compression.
- As the self ignition temperature of petrol is more than that of diesel, a petrol engine requires a spark plug for ignition of the charge.
- The charge is supplied into the cylinder combustion chamber through the opening of the accelerator.
- When the engine is in idle condition, a small quantity of charge enters the combustion chamber.
- The fuels used in the engines should be volatile. Volatility is the property of tendency of it to pass from the liquid into the vapor state at any given temperature.
- For easy starting, the fuel should be highly volatile.
- For smooth acceleration, a sufficient proportion of the gasoline must be sufficiently volatile.
- Gravity fuel feed system is adopted in all the two wheelers and three wheelers.
- Pressure feed system and pump system of fuel injection are adopted in four wheelers.
- The filler neck is closed by a cap, which is having a small hole for vent.
- The fuel pump works with the rotation of the crank shaft.
- With increase in speed of the crank shaft the pump supplies more quantity of fuel.
- The opening of the plunger supplies the quantity of fuel to the injector.
- The fuel injector is also called atomizer.
- There should not be any air bubble in the injection system pipe line.
- Removing the air bubble in the pipe line, filters and injection pump is called bleeding.
- Bleeding is done by opening the bleeding screws.
- Whenever the filter or pipe is replaced, bleeding should be done.

Exercise

1. Draw a neat diagram of diesel engine fuel system.
2. Mention the requirements of diesel engine fuel feed system.
3. What are the types fuel injection systems?
4. Briefly explain the construction of Fuel Injection Pump with the help of a neat sketch.
5. Describe about the Phasing and Calibration of a Fuel Injection Pump.
6. How do you mean the importance of a governor?
7. Mention the types of governors.
8. Explain the types of Governors with neat sketches.
9. Draw and explain with the help of a neat sketch the working of a fuel injector.
10. Mention the types of fuel injectors.

6. LUBRICATING SYSTEM

Lubrication is very important for reciprocating parts of an engine. Lubrication helps to provide cushioning to the reciprocating parts as well as it cleans the parts from dust. Lubrication helps to prevent the parts from corrosion and wear and tear.

6.1 Types of lubricants

The various lubricants used in automobiles are discussed below

- a. Motor Oil: Diesel engine oil and Spark Ignition engine oil differ primarily in detergency properties. Naphthalene base oils of low viscosity index may be used as diesel oils.
- b. Lubricants: These are used to prevent friction between the parts of any machine lubricants may be liquid like gear oil, semi solid like grease.
- c. Cylinder Oil: It is unfinished oil stock used directly as lubricant for steam engine cylinders or manufacture of bright stock. It is usually filtered but not dew axed.
- d. Neutral oil: It is light or low viscosity lubricating oil stock used for compounding of motor oils and light machine oils
- e. Bright stock: It is heavy or high viscosity lubricating oil stock for compounding of motor oils.

Lubricating is essentially required in motor vehicle maintenance. To supply lubricating oil between the moving parts is simply termed as lubrication. Lubrication of all moving parts is essential to reduce friction wear and to prevent seizure.

Objects of lubrication

1. To reduce friction between the moving parts.
2. To reduce wear of the moving parts.
3. To act as cooling medium for removing heat.
4. To keep the engine parts clean, especially piston rings and ring grooves, Oil ways and filters.
5. To absorb shock between bearings and other engine parts thus reducing engine noises and extending engine life.
6. To form a good seal between piston rings and cylinder walls.

6.2 Properties of lubricants

An engine lubricating oil must have certain properties or characteristics for it satisfactory function as follows.

1. Viscosity
2. Flash point
3. Fire point
4. Cloud point
5. Pour point

6. Oiliness 7. Corrosion 8. Color 9. Dilution
10. Emulsification
11. Physical stability 12. Chemical stability 13. Sulphur content
14. Specific gravity 15. Neutralisation
16. Adhesiveness 17. Film strength 18. Cleanliness

Viscosity: It is a measure of the resistance to flow or the internal friction of an oil.

Viscosity is one of the most important properties of engine lubricating oil. It is used universally to grade lubricants and it is measured by viscosometer.

Flash Point: The flash point is defined as lowest temperature at which the lubricating oil will flash when a small flame is passed across its surface.

Fire Point: If the oil is heated further after the flash point has been reached, the lowest temperature at which the oil will burn continuously is called the fire point.

Cloud Point: the oil changes from liquid state to a plastic or solid state when subjected to low temperatures. In some cases the oil starts solidifying which makes it to appear cloudy. The temperature at which this takes place is called the cloud point.

Pour Point: It is the lowest temperature at which the lubricating oil will pour. The pour point of an oil is lubrication of its ability to move at low temperatures. This property must be considered because of its effort on starting an engine in cold weather and on free circulation of oil through exterior feed pipes when pressure is not applied.

Oiliness: It is the characteristic property of the oil when it has oiliness. This property is highly desirable in helping the lubricant to adhere to the cylinder walls.

Corrosion: The corrosion has been defined as the destruction of a solid body by chemical or electrochemical action which starts intentionally from its outer surface. A lubricant should not corrode the working parts and it must retain its properties even in the presence of foreign matter and additives.

Color: Color of a lubricating oil is not of so much importance for its property expects as a test for checking the uniformity of any given grade or brand of oil.

Dilution: During the combustion petrol vapor may escape past the piston rings if the rings are worn or broken out considerable amount

such fuel is mixed with the crank case oil and dilutes it. Thus affecting its lubricating property. The rest to determine the amount of dilution in crankcase oil indicated how far the oil could be used when mixed with petrol vapor.

Emulsification: The lubricating oil, when mixed with water is emulsified and loses its lubricating property. The emulsification number is an index of the tendency of an oil to emulsify with water.

Physical stability: The lubricating oil must be stable physical at the lower and the highest temperatures between which the oil is to be used. At the lowest temperature there should not be any separation of solids and at the highest temperature it should not vaporize beyond a certain limit.

Chemical stability: The lubricating oil should also be stable chemical when there should not be any tendency for oxide formation. The oxidation produced being sticky clog the working parts, cause the faulty piston rings and valve action. The oil should also not decompose at high temperatures to form carbon which makes spark plug and valves faulty to function.

Sulphur content: If sulphur is present in considerable amount in the lubricating oil it promotes corrosion. The corrosion test shows the amount of sulphur content.

Specific Gravity: The specific gravity is a measure of the density of the oil. It is determined by a hydrometer that floats in the oil. And the gravity is read on the scale of the hydrometer at surface of the oil. The scale used is the recommended by the American petrol institute and the result is called the API gravity.

Neutralization number: The oil may contain impurities that are not removed while refining. It may contain alkaline or acid products. The neutralization number test is a simple procedure to determine acidity or alkaline of the oil.

Adhesiveness: It is the property of the lubricating oil due to which the oil particles stick to the metal surfaces.

Film Strength: It is the property of a lubricating oil due to which the oil retains thin film between the two surfaces even at high speed and load. The film does not break and the two surfaces do not come in direct contact.

Cleanliness: The lubricating oil must be clean. It should not contain dust and dirt particles. These impurities may either be filtered out or removed with the change of the oil a periodic intervals.

S A E number: The society of automotive engineers (S A E) rates oil viscosity in two different ways, for winter and for other than winter. Winter grade oils are tested at 0° and 210°F. There are 3 grades, SAE SW, SAE 10W and SAE 20W. The W indicates the oil is winter grade. For other than winter the grades are SAE 20, SAE 30, SAE 40 and SAE 50, all with out the W suffix. Some oil had multiple ratings which mean they are equivalent in viscosity, to several rating oils.

For example – SAE 30W oil is comparable to SAE 10W, SAE 20W and SAE 30W oil.

6.3 Requirements of lubricants for automobiles

1. To minimize the friction and wear.
2. To cool by carrying away heat.
3. To seal the pistons and thus preventing escape of gases in the cylinders with consequent loss of power.
4. To cushion the parts against vibration and impact.
5. To clean the parts as it lubricates them, carrying away impurities.
6. Lubrication is mainly required for main crankshaft bearings.
7. To lubricate the big end bearings.
8. Lubrication for the small end bearings.
9. Crankshaft bearings, piston rings and cylinder wall, timing gears, valve mechanism are lubricated.

6.4 Different systems of lubricating systems

The various systems of lubrication adopted in automobiles are

1. Petroil lubricating system
2. Splash lubricating system
3. Forced feed lubricating system
4. Dry sump lubricating system.

Petroil lubricating system: This system of lubrication is generally adopted in two stroke petrol engines like scooters, mopeds and motor cycles. It is the simplest form of lubricating system. It does not consist of any separate part like oil pump for the purpose of lubrication. The lubricating oil is mixed into the petrol itself while filling in the petrol tank of the vehicle, in a specified ratio. When the fuel goes into the crank chamber during the engine operation, the oil particles go deep into the bearing surfaces and lubricate them. The piston rings, cylinder walls, piston pin etc. are lubricated in the same way.

If the engine is allowed to remain unused for a considerable time, the lubricating oil separates off from petrol and leads to clogging of passages in the carburetor, resulting in the engine starting trouble.

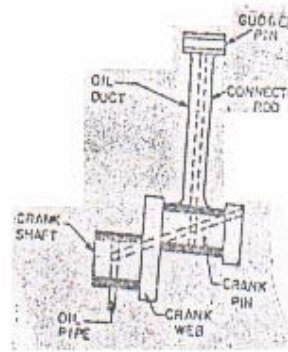

Small End Lubrication

Splash Lubrication system: In this system of lubrication, the lubricating oil is stored in an oil trough or sump. A scoop or dipper is made in the lowest part of connecting rod. When the engine runs, the dipper dips in the oil once in every revolution of the crankshaft and causes the oil to splash in the cylinder walls. This action effects the lubrication of the engine walls, piston rings, crankshaft bearings and big end bearings.

Splash system mostly works in connection with the pressure system in an engine, some ports being lubricated by splash system and other by pressure system.

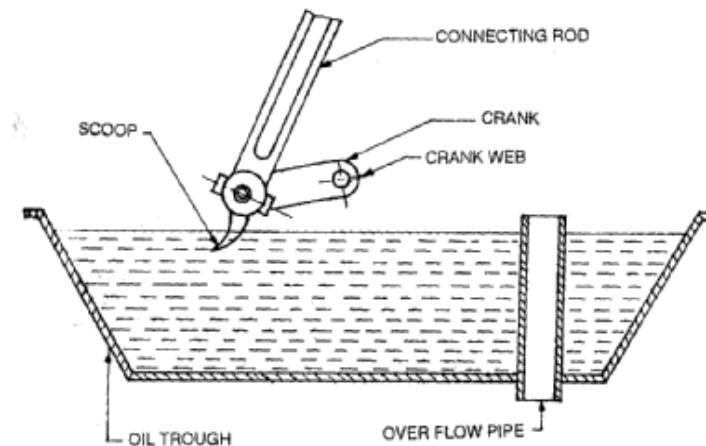

Splash Lubricating System

Pressure system: In this system of lubrication, the engine ports are lubricated under pressure feed. The lubricating oil is stored in a separate tank on the sump, from where an oil pump takes the oil through a strainer and delivers it through a filter to the main oil gallery at a pressure of 2-4 kg/cm². The oil from the main gallery, goes to the main bearings, falls back to the sump, some is splashed to lubricate the cylinder walls and the remaining goes through a hole to the crankpin. From the crankpin it goes into the piston pin through a hole in the connecting rod web, where it lubricates the piston rings.

For lubricating camshaft and timing gears, the oil is led through a separate oil line from the oil gallery. The valve tappets are lubricated by connecting the main oil gallery to the tappet guide surfaces through drilled holes. An oil pressure gauge at the instrument panel indicates the oil pressure in the system clear off the oil from dust metal particles and other harmful particles.

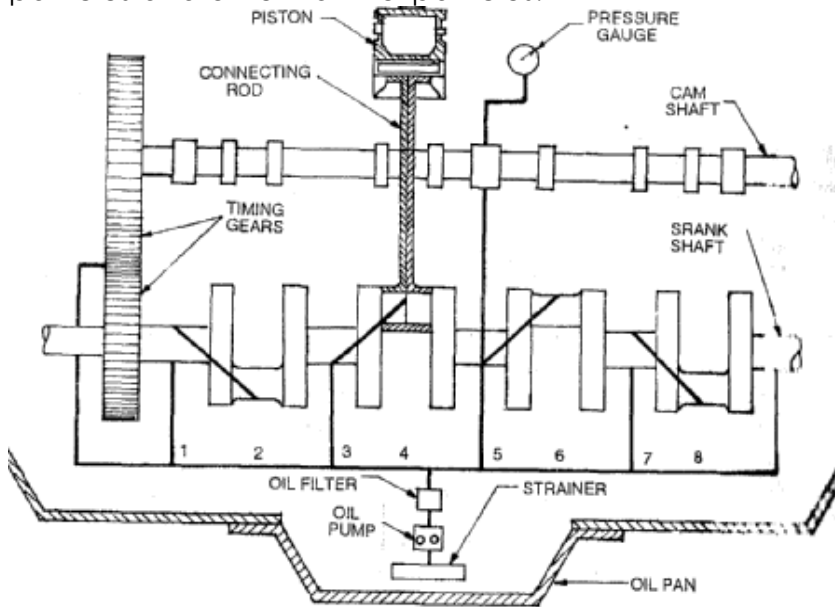

Pressure System of Lubrication

Parts of Lubricating System:

1. Oil sump or tank
2. Oil pump
3. Oil cooler
4. Oil filter and strainer
5. Oil pressure gauge
6. Oil level indicator
7. O.P. indicating light

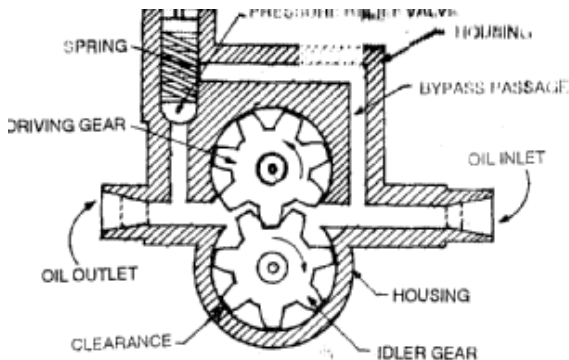

Gear Type Lubricating Pump

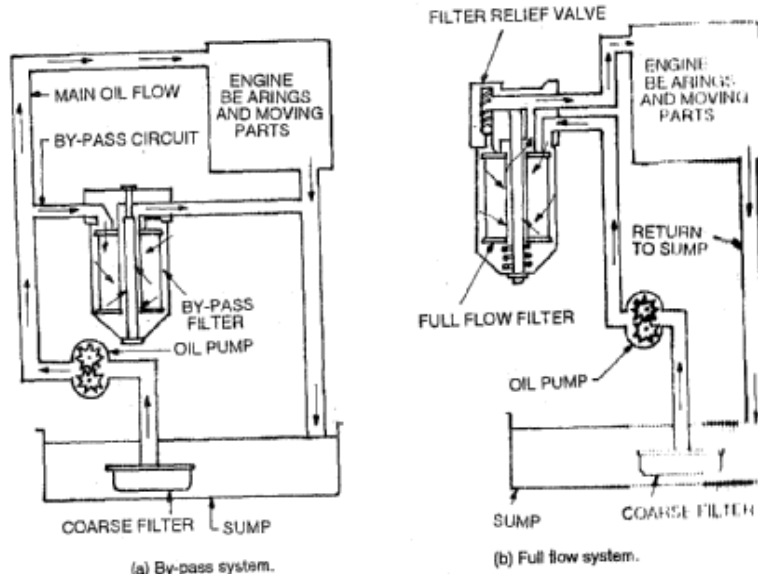

Dry Sump Lubricating System: The system in which the lubricating oil is stored in the oil sump is called wet sump system, like the pressure system. But the system in which the lubricating oil is not kept in the oil sump is known as dry sump system. In this system the oil is carried and stored in a separate tank from where it is fed to the engine. The oil which falls into the oil sump after lubrication is sent back to the oil tank by a separate delivery pump. The system consists of two pumps, one to feed the oil and the other to deliver it back to the oil tank. This system is used in situations where the vehicle has to change its position continuously, like in aircrafts. The main advantage of this system is that there is no chance of break down the oil supply during up and down movement of the vehicle.

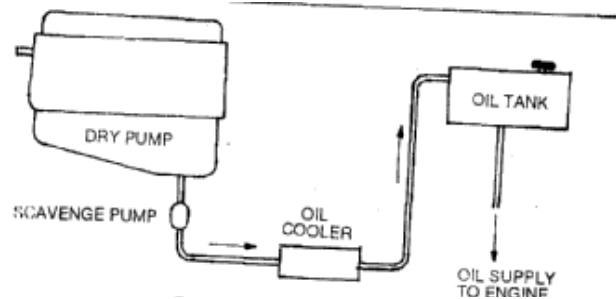

Dry Sump Lubrication

6.5 Function of oil filters

The main function of the oil filters is to filter out the dirt or grit particles from the oil. The oil filters clear the dust particles settled in the oil through the burning of the fuel. Thus the oil filters are helpful to clean the various parts of an engine from dust and dirt.

6.6 Types of filtering systems

There are two types of filtering systems. They are

1. Full flow system
2. By pass flow system.

In **Bypass filter system**, the whole of the oil does not pass through the filter at the same time, but some of the oil without being filtered goes to the bearings. Remaining oil passes through the filter and then goes to bearings. When the engine is running continuously for a long period, the whole oil is however filtered.

In **full flow system**, the whole oil passes first through the filters and then goes to the bearings. If the filter is clogged due to any reason, the system fails completely and bearings would be starved.

6.7 Types of filtering elements

Different types of filtering elements are used in automotive engines.

1. Cartridge type
2. Edge type
3. Centrifugal type.

The Cartridge type consists of a filtering element placed in a metallic casing. The casing has inlet and outlet oil pump enters casing through the filtering element, which takes up all the impurities. The filtered oil then comes out from the casing and goes to the oil gallery. The filtering element may be cleared when clogged.

The Edge type filtering element consists of a number of discs in a casing through which the oil passes. The alternate discs are mounted over a spindle and discs, between these are fixed to a separate square rod. The clearance between the discs is only a few thousand of centimeter. When the oil flows through this small clearance, it leaves impurities on the disc peripherals.

The Centrifugal type consists of a stationary casing, rotor casing, central spindle and tubes with jets. The important oil enters the hollow central spindle and through holes around its periphery, the oil goes to the rotor casing. From the rotor casing the oil goes in the tubes, at the ends of which jets under pressure, the reaction of which gives the motion to the rotor casing so that it starts rotating. The oil from the jets impinges on the walls of the stationary casing under heavy pressure, where the impurities are retained and the clean oil falls below which is taken for use. The filter walls are cleared periodically.

6.8 Necessity of Crankcase Ventilation

The products of combustion contain mainly nitrogen, water and carbon dioxide, sulphuric acid articles may also be present due to

sulphur content in the fuel. It is quite possible that the product of combustion may leak through the piston rings into the crankcase oil by slipping past the piston rings. Thus the lubricating oil in the crankcase becomes dilute when mixed with water and gasoline which leak past the piston rings. The acid causes corrosion of the crankcase metals as water does. If either or both are allowed to enter and remain in the crankcase, the crankcase ventilation removes all these unwanted particles from the crankcase, which leak past the piston rings. It prevents the lubricating oil from becoming dilute and corrosion of crankcase metals due to acid formation.

In a positive crankcase ventilation, the crankcase vapor are returned to the engine through the intake manifold, instead of being exhausted into the atmosphere. The crankcase outlet tube is connected to the manifold just beneath the carburetor. So that the vapors are drawn into the intake manifold and utilized into the cylinder during the operation.

6.9 Effect of sludge to the lubrication system

When the water is mixed in oil and the mixture is churned up for a certain time, a thick, creamy black substance is formed known as water sludge.

In the crankcase, the water collects in two ways. First, the water is formed as a product of combustion. Second the water enters through the crankcase ventilation system with moist air which the engine is cold, the water drops into the crankcase and mixes with the lubricating oil. By the action of the crankshaft the mixture is churned up and water sludge is formed. Dirt and carbon also mix in the water sludge making it black.

The water sludge clogs oil screws and oil lines, preventing normal circulation of lubricating oil to engine parts. This can result in engine failure from oil starvations.

Summary

- ✿ Lubrication plays an important role in smooth running of the automobile.
- ✿ Lubrication provides the engine reciprocating parts neat and clean.
- ✿ Proper lubrication helps to maintain the correct nomenclature of the engine parts for a long timer.
- ✿ With proper lubrication the life of an engine as well as the vehicle can be increased.
- ✿ Lubrication decreases the noises inside the engine.
- ✿ The engine reciprocating parts are to be lubricated by the lubricating oil supplied from the sump or through the fuel.
- ✿ The oil filters filter out the dust and dirt entering the engine.
- ✿ Society of Automobiles had given different grades to the lubricating oils to be used for various engine parts and according to the load and climatic conditions.
- ✿ The engine parts will be damaged with the usage of wrong grade lubricating oil.

Exercise

1. What are the types of lubricants used in automobiles?
2. Mention any four important properties of lubricating oils.
3. What is meant by S A E Number?
4. Mention the requirements of lubricating system.
5. Explain the types lubricating systems.
6. Explain the splash lubricating system with the help of a neat sketch.
7. With the help of a neat sketch explain the pressure lubricating system.
8. Explain the filtering elements used in lubricating system.
9. How do you explain the crankcase lubrication.
10. Write about sludge formation in lubrication.
11. Give the various grades of lubricants used for engine, gearbox, differential, steering gearbox in different types of vehicles.

7. Cooling System

7.1. Necessity of cooling system

If the temperature developed is not dissipated out, it may cause severe damages to the engine. The excess heat developed inside the engine should be removed out frequently so as to prevent the engine from overheating. If the engine is not dissipated its excess heat, which may cause to break the lubricating film between the moving parts. If the lubricating oil film is broken it causes the engine parts to weld. At about 15 % of the total heat produced is utilized for useful work at the crankshaft. Remaining amount of heat is absorbed in friction, removed by exhaust gases and taken by cooling system the cooling system is designed to remove above 30 to 35% of heat produced in the engine cylinder. As the temperature should not reach excessive values, they should be cooled sent out of the engine surroundings. It is also to be noted that the engine is quite in efficient when cold. The cooling system is so designed that it prevents cooling until the engine reaches to its normal operating temperature. When the engine warms up, the cooling system begins to function. It controls rapidly when the engine is too hot, and it cools slowly or not at all when the engine is cooled or is warming up. Most engines are designed to operate in a definite temperature range which will insure correct clearances between parts, promote vaporization of the fuel, keep the oil at its best viscosity and prevent the condensation of harmful vapor. Thus the duty of the cooling system is to keep the engine from getting too hot and not to keep it too cool.

7.2 Disadvantages of overcooling & under cooling

Engine should be cooled within a particular temperature limits. It should not be too cooled or too heated up. Getting the engine too much cooled is called overcooling. And if the engine is over heated it is to under cool. Both under cooling and over cooling have individual disadvantages. Over cooling results in the increase of viscosity of the lubricating oil, which in turn result in the increase of friction between the moving parts.

If the engine gets warmed up excessively, it should be cooled so as to keep the correct alignment of the engine. Under cooling also keeps the engine in correct position and increase the life of the engine. Evaporation of lubricating oil that lubricates the piston and cylinder wall is also another reason of under cooling. This will result in metal to metal contact of the piston and cylinder wall leading to piston crown. Burning of and warping of exhaust valves setting up of thermal stresses in the cylinder, cylinder head and piston. This may lead to cracking of them.

7.3. Types of cooling system: -

Engine cooling is of two types. They are air cooling and water cooling.

A. Direct or air cooling: - Air cooling is used on engines in scooters, motorcycles, aero planes, small stationary engines. This system employs air as the cooling medium. The air remains indirect contact with the exterior of engine surface and transfers heat from cylinders to the atmosphere. Air cooling system is simple in layout, occupies small area on the vehicle. It contains much less spare parts and has almost no moving components.

1. Air jacket cooling 2. Natural air cooling 3. Forced air cooling.

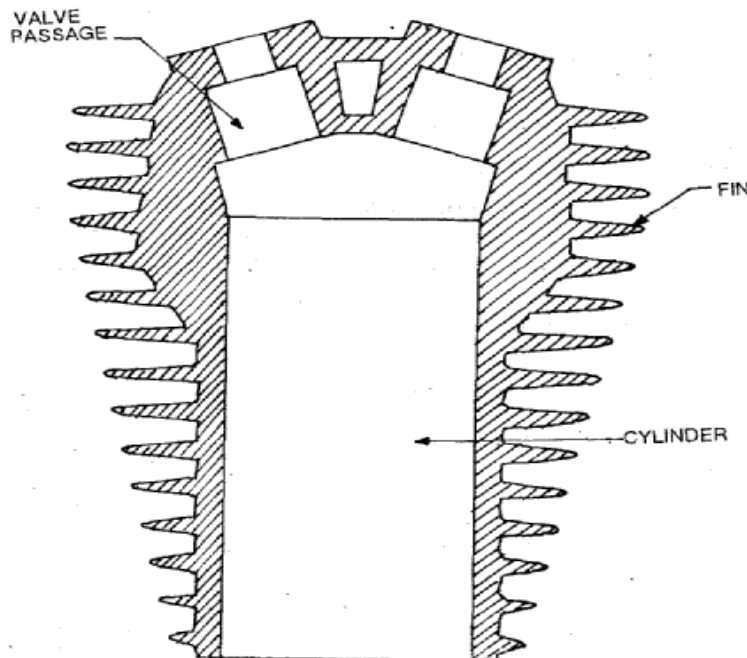

Forced Air Cooling: - It is well known fact that the rate of heat transfer due to convection increases with an increase in the velocity of the air flowing over a hot body.

Engine mounted on sunny zip, Bajaj auto vehicle, LML, Kinetic Honda employ this kind of cooling.

Natural Cooling: - In normal course, large part of an engine exposed to the atmospheric air, when the vehicle runs the air at certain relative velocity impinges upon the engine and sweeps away its heat. The heat carried away by the air is due to natural convection. Therefore this method is known as natural air cooling. As the heat dissipation is a function of frontal cross-sectional area of the engine, therefore there exists a need to enlarge this area.

Air Jacket Cooling: - In this cooling arrangement, the air is made to pass through the small passages formed in the cylinder block and

the cylinder head. The air is passed through a singular multi passages, either naturally or by artificial means.

7.4 Water Cooling or Liquid cooling system: -

Air cooling of an engine tends to become less effective when number of cylinders increases in one engine. This is because of reduced effective surface area around each cylinder. This inefficiency can be over-come by use of water cooling system on multi cylinder engines.

1. Thermo Syphon Cooling System
2. Pump Circulation or Forced Water Cooling System.

Thermo Syphon Cooling System: - This system involves flow of water under gravity. It does not depend on any external source to circulate the liquid coolant. Convective currents carry heat from bottom to the top of the system as cold water is heavier than the hot water. Since the water in the jackets surrounding the cylinder is heated. It becomes lighter and rises up. The heated water enters into the radiator through the upper connection and when cooled by the air passing through the radiator core. It becomes heavier and settled to the bottom of the radiator.

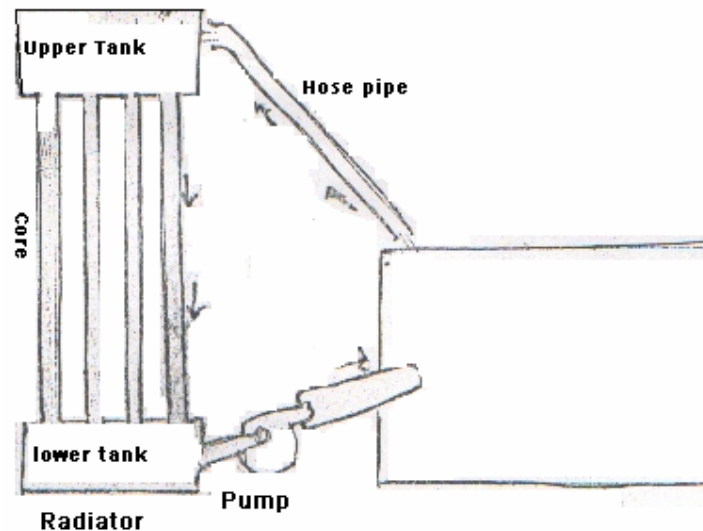

7.4 Thermostat water cooling system:

In this system of water cooling, the circulation of water is obtained due to the difference in densities of hot and cold regions of the cooling water. There is no pump to circulate the water. The hot water from the engine jacket being lighter, rises up in the hose pipe and goes in the radiator from the top side. It is cooled there and hence goes down at the bottom of the radiator, from where it goes again in the engine jackets. The system is quite simple and cheap, but the cooling is rather

slow. To maintain continuity of the water flow, the water must be maintained up to a certain minimum level. If the water level falls down, the circulation will discontinue and the cooling system will fail.

A thermostat valve is used in the water cooling system to regulate the circulation of water in system to maintain the normal working temperature of the engine parts during the different operating conditions. The thermostat valve automatically work in the cooling system. When the engine is started from cold, the thermostat valve prevents the flow of water from engine to radiator so that the engine readily reaches to its normal working temperature, after which it automatically comes into action. Generally the thermostat valve does not permit the water below 70°C.

There are two types of thermostats used in automobiles. They are bellow type and pellet type thermostat. Both the thermostat valves works on the same principle as a heat unit operating a valve.

The working of bellow type thermostat is explained with the help of figure. The heat unit consists of a closed bellows filled with a volatile liquid under reduced pressure. When the bellows is heated, the liquid vaporizes and creates enough pressure to expand the bellows. The movement of the bellows operate a linkage which open the valve to pass the water through it. When the bellows is cooled, the gas condenses, the pressure is reduced and the bellows collapse to close the valve thus stopping the water circulation.

In the pellet thermostat, the heat unit consist of a sealed in wax pallet, which expands on heating and contracts on cooling. The pellet is connected by piston and flange to a valve so that on expansion of the pellet it opens the valve. When the pellet contract on cooling, a coil spring closes the valve.

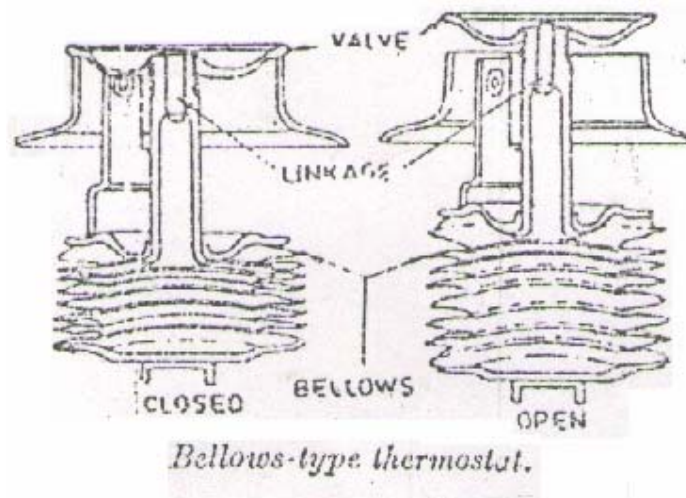

7.5 Construction and working of water pump, radiator

Water Pump:

A pump is used in the water cooling system to increase the velocity of the circulating water. Impeller type pump is mounted at the

front end of the cylinder block between the block and the radiator. The pump consists of a housing with inlet and outlet, and an impeller. The impeller is a flat plate mounted on the pump shaft with a series of flat or curved blades or vanes. When the impeller rotates, the water between the blades is thrown outwards by centrifugal force, and is forced through the pump outlet and into the bottom of the radiator, and the water from the radiator is drawn into the pump to replace the water forced through the outlet.

The pump is driven by a belt to the drive pulley mounted on the front end of the engine crankshaft. The impeller shaft is supported on one or more bearings. A seal prevents water from leaking out around the bearing.

The pack less type pump is used in modern engine. The packing gland type pump is found only in older models.

Radiator:

The radiator is a device for having a large amount of cooling surface to the large amount of air so that the water circulating through it is cooled efficiently. It consists of a upper tank and a lower tank and between them a core. The upper tank is connected in the water outlet or outlets from the engine jackets inlet through the water pump. The core is a radiating element, which cools the water.

There are two basic types of radiator cores – tubular type and cellular type. In tubular type core the upper and lower tanks are connected by a series of tubes through which water passes. Fins are placed around the tubes to improve heat transfer. Air passes around the outside of the tubes, between the fins, absorbing heat from the water in passing. In cellular type core, air passes through the tubes and the water flows in the spaces between them. The core is composed of a large number of individual air cells which are surrounded by water. Because of its appearance the cellular type usually is known as a honeycomb radiator, especially when the cells in front are hexagonal in form.

In tubular radiator, because the water passes through all the tubes, if one tube becomes clogged, the cooling of any passage results in a loss but of a small part of the total cooling surface.

Radiators are also classified according to the direction of the water flow through them. In some, the water flows from top to bottom – down flow type radiators. In other, the water flows horizontally from an input tank on one side to another tank on the other side – cross flow type radiator.

Radiators are usually made of copper and brass because of their high heat conductivity. The various sections of the radiator are most completely joined together by soldering.

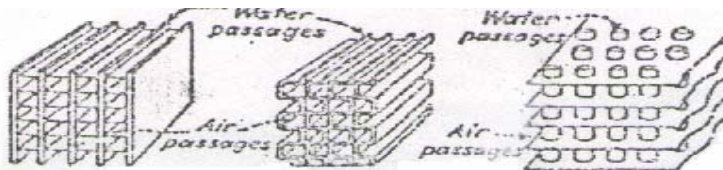

Tubular radiator sections

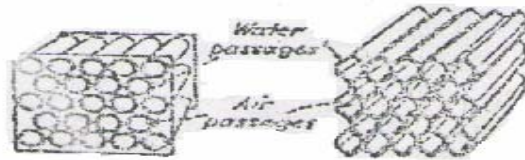

cellular radiator sections
Types of radiator cores

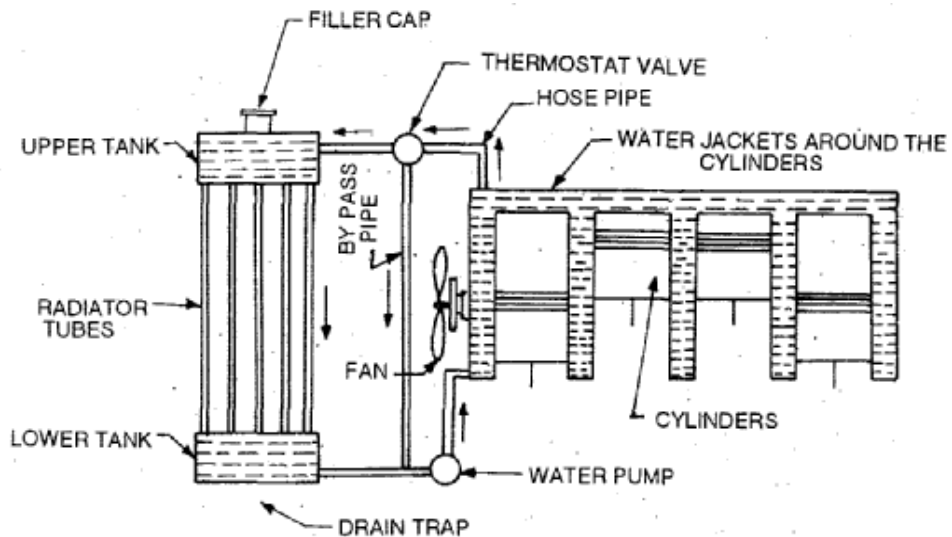
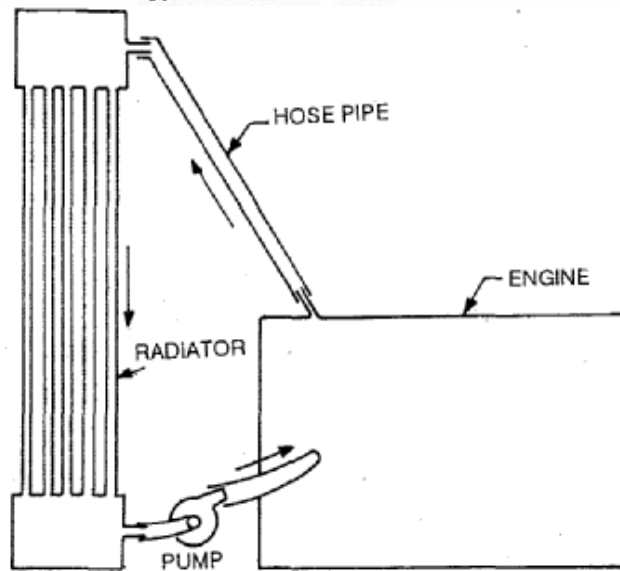

WATER COOLING SYSTEM OF FOUR CYLINDER ENGINE

Anti freezing and anti rusting additives

When water in the cooling system freezes it may cause cracking the cylinder block, pipes and the radiator. Freezing of water occurs where the atmospheric temperature is very less. To prevent freezing, antifreeze mixtures or solutions are added in the water. The most commonly used antifreeze materials are

Wood alcohol, denatured alcohol, glycerine, Ethylene glycol, propylene glycol and mixture of alcohol and glycerine.

The alcohol evaporates quickly. So it should be checked frequently. Ethylene glycol is a permanent type antifreeze material. Glycerine and glycol are although costly but do not evaporate readily and hence prove cheaper in long run. But they should not enter the engine parts as they seizure of the moving parts. The lower the temperature, the higher is the percentage of antifreeze material.

Anti rusting additives prevent the engine parts from rusting and corrosion.

The antifreeze material should mix with the water readily. It should prevent freezing of the mixture at lowest temperatures. It should circulate freely in the cooling system. It should not damage the cooling system by corrosion action. It should not deposit any foreign material.

Summary

- ❖ An efficient cooling system removes 30 to 35% of the heat generated in the combustion chamber.
- ❖ Too much removal of the heat decreases thermal efficiency of the engine.
- ❖ Excess heat can be cooled by air cooling, water cooling, liquid cooling and stream cooling.
- ❖ The amount of heat dissipated depends on the surface area of metal, rate of air flow, conductivity of material.
- ❖ Air cooling is cheaper and faster.
- ❖ Air cooled engines more noise.
- ❖ The total length of the finned cylinder barrel is from 1 to 1 ½ times the cylinder bore.
- ❖ The length of the fins varies from one-quarter to one-third of the cylinder diameter.
- ❖ The cooling radiator fan usually absorbs about 1 H.P. for every 15 to 20 H.P. output.
- ❖ Sometimes, the flywheel is designed to function as a cooling fan.
- ❖ Water cooling is of two types – thermo siphon and pump circulation system.
- ❖ Radiator is the main component of cooling system.
- ❖ The water pump is used in the water cooling system to increase the velocity of the circulating water.

- ❖ The water pump is used in heavy duty engines.
- ❖ The radiator fan is rotated by the crankshaft.
- ❖ Water jackets are cast in the cylinder blocks and cylinder heads.
- ❖ Higher boiling point liquids like glycerine, ethylene glycol are used in liquid cooling system.
- ❖ A temperature indicator is mounted on the instrument panel.

Exercise

1. Explain the necessity of cooling system.
2. Explain the disadvantages of over cooling over under cooling.
3. Enumerate the air cooling system.
4. With the help of a neat diagram explain water cooling system.
5. How do you study the radiator?
6. Explain the construction of water pump.
7. Write a short note on anti freeze and anti rust materials.

8. MANIFOLDS AND MUFFLERS

8.0 INTRODUCTION:

Manifold is a pipe used for the sending or passing through of the air fuel mixture or the exhaust gases. These are pipe like structures. Heavy engines are constructed with through passages which are used as manifolds.

Muffler is a device used for the absorption of the noises created by the exhaust gases. The mufflers minimize the sound and velocity intensity and thereby help in minimizing the sound pollution.

8.1 Necessity of inlet and exhaust manifold:

The inlet manifold is used to guide or send the charge into the cylinder. The inlet manifold is a passage made in the casting in case of heavy engine blocks. The necessity of inlet manifold came into existence for the supply of charge (air in case of diesel engine and air-fuel mixture in case of petrol engine).

The exhaust manifold guides the exhaust or burnt out gases to pass into the muffler. The exhaust manifold should be strong enough to withstand the heat liberated by exhaust gases.

It is only the manifolds which are used to send the charge into and out of the cylinder.

8.2 Consideration for a good manifold design:

The following things are to be considered while designing the manifold of an engine.

1. The amount of charge required into the engine cylinder.
2. The quantity of charge entering into the cylinder.
3. Scope for the entry of fuel into the cylinder easily. Design should be smooth such that the fuel should enter easily.
4. Ability to resist to high temperatures those are developed by heat of compression or heat of ignition.
5. The material of the manifold should be such that it should send more of the exhaust heat to the surroundings.

8.3 Types of manifolds:

There are two types of manifolds viz. Inlet manifold and exhaust manifold.

INLET MANIFOLD:

The intake manifold is to distribute the air and petrol equally to all the cylinders through inlet valves. There are usually made out of

aluminum alloy and have smooth finish in its air passage so that there is no restriction due to rough surface. Intake manifold is fixed to cylinder head with studs or bolts with packing seal placed at each opening to ensure airtight joint.

Functions of intake manifold:

1. It should distribute air-fuel mixture properly.
2. It should supply equal amount of charge to each cylinder.
3. It should maintain the proportion of air-fuel mixture properly.
4. It accommodates air cleaner.

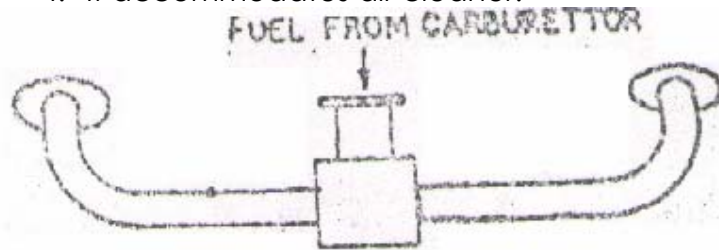

Intake manifold for a four cylinder engine

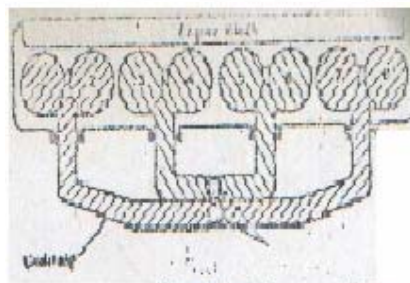

Dual intake manifold.

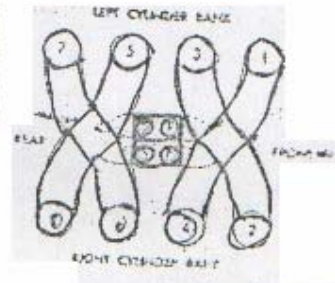

Four barrel intake manifold

Exhaust Manifold:

It is like inlet manifold but is made of cast iron. It connects exhaust ports of cylinder head with the exhaust packing in between to make it gas tight fitting. On the other end it is connected to exhaust pipe and muffler. It is a collection agency for exhaust gases let out by the engine having many joining flanges each connected to exhaust port of cylinder head. The exhaust gases coming out of different exhaust ports of cylinder block are gathered in exhaust manifold and rushed out with high velocity to exhaust pipe.

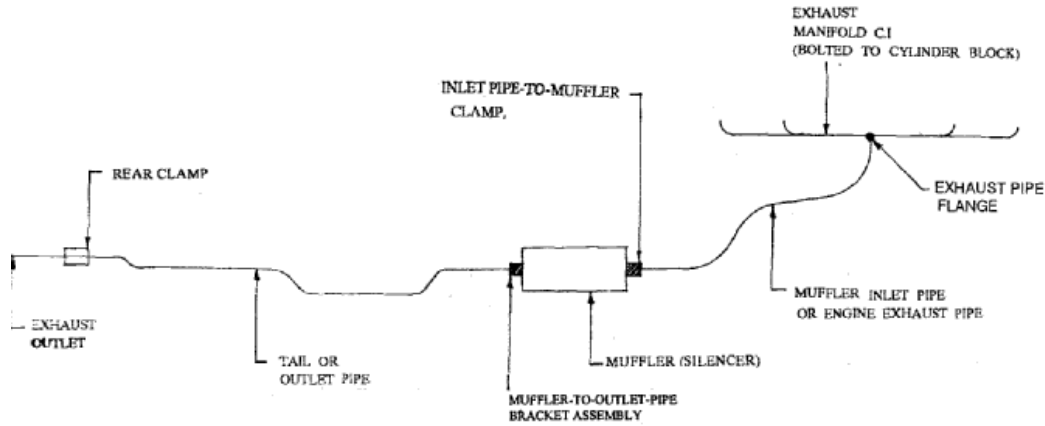

Exhaust Pipe:

The exhaust pipe is round curved pipe whose one end is fixed with the manifold with suitable flange and the other end clamped with exhaust muffler. In most of the exhaust pipes as used on automobile is placed a flexible conduit pipe so that engine vibrations are taken care of and are not transmitted to the muffler which is fixed with the chassis.

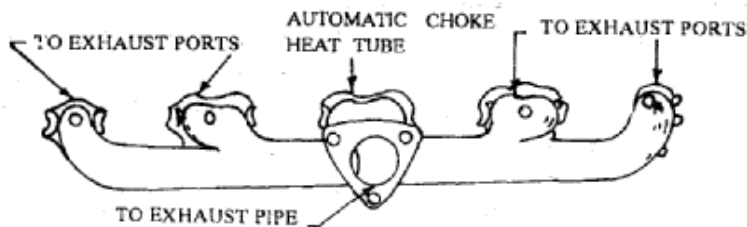

8.4 Construction and working principle of air cleaner – Necessity of air cleaner

Air Cleaner:

It cleans the air going to the cylinder. We know that air contains lot of minute particles of dust and dirt which sometimes are not visible to the naked eye. The vehicle running on kucha road quarries, mines etc. are subjected to heavy duty conditions.

The dust has to be trapped from the air before it gets into the cylinder with the help of air cleaner.

There are various types of air cleaners used now a day. These are generally classified as under.

- a) Wet type air cleaner
- b) Dry type air cleaner
- c) Pre-cleaner.

8.5 Construction and working principle different types of silencers – function of silencer.

Silencer is connected between the engine exhaust pipe and tail pipe. It's function is to reduce the noise of exhaust gas as much as possible.

Summary

- Manifold is a passage for the flow of charge or air into and out of the cylinder.
- In the Manifold design care should be taken towards the material and strength of the material used.
- The property of the material is to be taken into consideration for designing the manifold.
- Every engine is constructed with an inlet and an outlet manifold.
- The manifolds are constructed within the engine block for the heavy duty engines.
- Air cleaner is used to clean the foreign particles in the air.
- Muffler is also called as silencer.
- A silencer is used to minimize the velocity of the exhaust gases by sending it through a number of baffle plates.
- A muffler reduces the noise of the exhaust gases.
- The baffle plates are frequently cleaned of to avoid the carbon particles.

Exercise

Short answer questions:

1. What is a manifold?
2. What is the main criterion taken in the design of a manifold?
3. Is a manifold attached to the engine block externally for a heavy duty engine?
4. How many types of manifolds are used in an engine?
5. What is the use of a muffler?
6. How the silencer of a vehicle is cleaned?

7. Why the silencer of a car is cleaned?

Essay questions:

1. Explain the construction and working of the manifolds of an engine.
2. Explain the construction and working of the air cleaner of an engine.
3. How do you infer the necessity of an air cleaner and a silencer?
4. Explain the construction of a silencer used in a vehicle.

9. PERFORMANCE OF I.C. ENGINE

9.1. Need for Engine performance testing:

To study the various performances, engine construction, maintenance the performance testing is required. The correct running of the engine and comfort to the passengers etc can be easily found out by studying the performance of an engine. For the performance testing the concept of TDC, BDC, Stroke, Bore of the cylinder etc are to be known.

TOP DEAD CENTRE: The top most position refers to T.D.C. as shown in

Figure.

Bottom Dead Centre: The bottom most position refers to B.D.C. as

shown in figure.

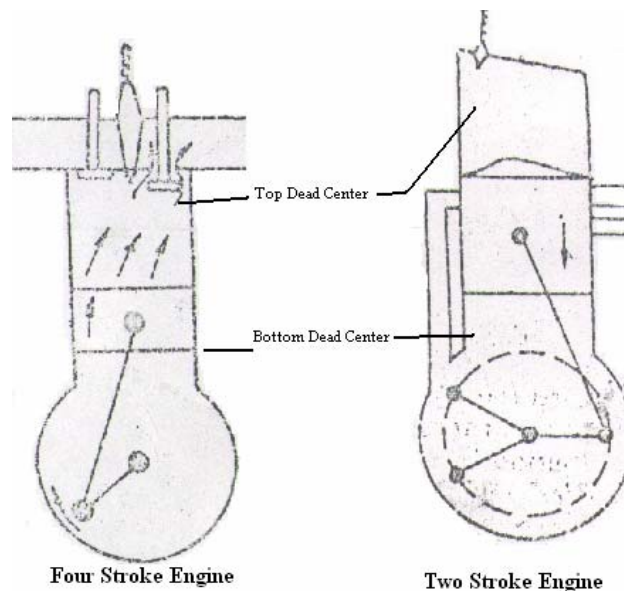

Stroke and Bore: The displacement of piston within a cylinder between T.D.C. and B.D.C. is called as Stroke. The stroke is denoted by 'L'. It is measured in mms.

The bore 'D' is inner diameter of the cylinder. It is measured in mms.

Clearance Volume: The space above the piston, when the piston is at

TDC is known as clearance volume.

Cylinder Volume: The volume above the piston when the piston is at BDC is called cylinder volume or cylinder volume is the sum of the clearance volume and stroke volume.

Cubic Capacity: The cubic capacity of an engine, or engine displacement or engine size is the product of the stroke volume in one cylinder and the number of cylinders in the engine.

Compression ratio: The compression ratio is the ratio of the cylinder volume to the clearance volume. The compression ratio represents the ratio of the volume occupied by the charge before compression to that after compression.

Torque: Torque is the turning moment. In the case of an engine it is usually referred at the crank shaft of the engine.

Torque refers to the average turning moment or rotation exerted on the crankshaft by the gases acting on the piston during a cycle. Torque (T) is measured in Kgf m or Nm.

9.2 Different types of engine powers i.e. BHP, IHP, FHP

Integrated Horse Power: The power actually developed inside the engine cylinder by the combustion of fuel is called "Indicated Horsepower". It is given by the relation.

$$\begin{aligned} \text{I.H.P.} &= \frac{PLAN}{4500} \text{ for a 2-stroke engine} \\ &= \frac{PLAN}{2 \cdot 4500} \text{ for a 4-stroke engine.} \end{aligned}$$

Where P= Mean effective pressure in Kg/cm²

L= Length of Stroke in meter.

A= Area of Cross section of the piston in cm²

N = Number of revolutions of the crankshaft.

For a 2stroke engine, No. of explosions = No. of RPM of the crankshaft.

For a 4 stroke engine, No. of explosions = $\frac{1}{2}$ * No. of RPM of the crankshaft.

Brake Horse Power (B.H.P.): The power which the engine actually delivers to do the outside work is called Brake Horse Power. It can be measured by some measuring instrument like Prony brake dynamometer.

$$\text{B.H.P.} = 2\pi NR(W-S) / 4500 = \pi DN(W-S) / 4500$$

Where D = Diameter of the Brake Drum = 2R in meters.

N = No. of revolutions/mm of the crankshaft.

W = load on the brake in Kg.

S = spring balance reading in Kg.

Frictional Horse Power (F.H.P.): The power lost in friction in engine mechanism is called frictional horse power. It is actually equal to the difference between the I.H.P. and B.H.P.

$$\text{F.H.P.} = \text{I.H.P.} - \text{B.H.P.}$$

9.3 Different types of efficiencies

Engine Efficiencies: The term efficiency means the relationship between the effort exerted and the results obtained. Engine efficiency, the efficiency as applied to engine, is the relationship between the power delivered and the power obtained.

Mechanical efficiency: The mechanical efficiency is the ratio of brake horse power to indicated horse power.

$$\text{Mechanical efficiency} = \text{B.H.P.} / \text{I.H.P.} = \text{B.H.P.} / (\text{B.H.P.} + \text{F.H.P.})$$

Thermal efficiency: It is the ratio of B.H.P. or I.H.P. to that heat energy of the fuel supplied during the same interval of time.

Efficiency based on I.H.P. is called Indicated Thermal efficiency and is given by

$$\text{Indicated thermal efficiency } (\eta_{th}) = \text{I.H.P.} * 4500 / W * Q * J.$$

W = Weight of the fuel supplied in Kg. / mm.

Q = heating value or calorific value of fuel in K Cal / Kg.

J = Mechanical equivalent of heat = 427.

Brake Thermal Efficiency: The efficiency calculated on Brake Horse Power is called Brake Thermal Efficiency.

$$\text{Brake Thermal Efficiency} = \text{B.H.P.} * 4500 / W * Q * J$$

Volumetric efficiency: The volume of air-fuel mixture drawn into the cylinder at atmospheric pressure during the intake stroke compared to the volume of the cylinder is known as volumetric efficiency.

9.4 Performance terms relating to an I.C. Engine

Specific Fuel Consumption: In engine test the fuel consumption by an engine is measured as flow rate i.e. mass flow per unit time. The more important parameter is the specific fuel consumption (SFC). This is the fuel flow rate per unit power output. It indicates how efficiently an engine is using the fuel supplied to it in producing work.

Heat balance sheet: During a specific period, the total heat produced inside the cylinder must be equal to the sum of the various heat losses and that utilized for useful work. All these items are recorded in a tabular form called the heat balance sheet.

Performance Curves: The word performance for an engine is generally used for designating the relationship between power, speed and fuel consumption. For variable speed engines the rated horse power at a certain speed does not give enough information. The performance curve helps to obtain necessary information.

Summary

- ❖ It is the primary responsibility to know about the performance of an engine.
- ❖ The maintenance of a vehicle engine is proper if the performance is good.
- ❖ The power of an engine is expressed in terms of Horse Power.
- ❖ The fuel consumption given by an engine is given by the IHP of the engine.
- ❖ Brake thermal power is the horse power developed by the engine at the flywheel.
- ❖ Dynamometer is a device used to measure the brake thermal power.
- ❖ IHP is the theoretical power developed by the engine.
- ❖ If the FHP is minimized the efficiency of the engine can be improved.
- ❖ Performance curves give clear idea of the engine position.

Exercise

1. How do you find the need of performance testing of an engine?
2. Define the terms Brake Thermal efficiency, Indicated Thermal Efficiency and Volumetric efficiency.
3. What do you mean by the terms – BHP, IHP and FHP?
4. Expand the terms – BHP, IHP and FHP.
5. What is meant by Specific Fuel Consumption? Write its units.
6. Write a short note on Performance Curves.