

1. CONVERSION OF AMMETER INTO VOLTMETER

Aim :

To study the Conversion of Ammeter into Voltmeter

Operettas Required :

An Ammeter, Multiplier Resistors, DC Power supply and connecting wires.

Theory :

Ammeter The basic movement of a d.c. ammeter is a PMMC d'Arsonval galvanometer. The coil winding of a basic movement is small and light and can carry very small currents since the construction of an accurate instrument with a moving coil to carry currents greater than 100 mA is impracticable owing to the bulk and weight of the coil that would be required.

When heavy currents are to be measured, the major part of the current is bypassed through a low resistance called a "shunt". The basic movement and its shunt to produce an ammeter.

The resistance of the shunt can be calculated using conventional circuit analysis.

Where R_m = internal resistance of movement

$I_m = I_{fs}$ = full scale deflection current of movement.

I = current to be measured.

Since the shunt resistance is in parallel with the meter movement, the voltage drops across shunt and movement must be the same.

$$\text{or } I_{sh} R_{sh} = I_m R_m \quad \therefore R_{sh} = \frac{I_m R_m}{I_{sh}}$$

$$\text{But } I_{sh} = I - I_m, \text{ therefore we can write } R_{sh} = \frac{I_m R_m}{I - I_m}$$

$$\therefore \frac{I}{I_m} - 1 = \frac{R_m}{R_{sh}} \quad \text{or} \quad \frac{I}{I_m} = 1 + \frac{R_m}{R_{sh}}$$

This ratio of total current to the current in the meter movement is called Multipling Power of shunt.

$$\therefore \text{Multipling power } m = \frac{I}{I_m}$$

$$= 1 + \frac{R_m}{R_{sh}}$$

$$\therefore \text{Resistance of shunt } R_{sh} = \frac{R_m}{m - 1}$$

Conversion of Ammeter into Voltmeter :

Remove shunt resistance to the meter and connect multiplier resistance in series to the meter than the meter becomes Voltmeter.

Calculation of Multipliers :

Individual Multipliers :

We can obtain different voltage ranges by connecting different values of multiplier resistors in series with the meter. The number of these resistors is equal to the number of ranges required. Multiplier resistors R_{s1} , R_{s2} , R_{s3} and R_{s4} which can be connected in series with the meter by a range selector switch. Consider that the ranges desired are V_1 , V_2 , V_3 and V_4 , then the corresponding multiplier resistances can be obtained.

$$R_{s1} = (m_1 - 1) R_m,$$

$$R_{s2} = (m_2 - 1) R_m,$$

$$R_{s3} = (m_3 - 1) R_m,$$

$$R_{s4} = (m_4 - 1) R_m,$$

$$\text{Where} \quad m_1 = \frac{V_1}{v}, \quad m_2 = \frac{V_2}{v},$$

$$m_3 = \frac{V_3}{v}, \text{ and } m_4 = \frac{V_4}{v}$$

Design of Voltmeter Case Study:

A basic d'Arsonval meter movement with an internal resistance $R_m = 100 \Omega$, and a full scale current of $I_m = 1 \text{ mA}$, is to be converted into a multi-range d.c. voltmeter with ranges of 0-10 V, 0-50 V, 0-250 V and 0-500 V. Find the values of various multiplier resistances.

Solution :

$$\text{Voltage across the meter movement } v = I_m R_m = 1 \times 100 = 100 \text{ mV.}$$

The voltage multiplying factors are:

$$m_1 = \frac{10}{100 \times 10^{-3}} = 100; \quad m_2 = \frac{50}{100 \times 10^{-3}} = 500;$$

$$m_3 = \frac{250}{100 \times 10^{-3}} = 2500; \quad m_4 = \frac{500}{100 \times 10^{-3}} = 5000;$$

The voltage multiplying resistors are:

$$R_1 = (m_1 - 1) R_m = (100 - 1) \times 100 = 9900 \Omega,$$

$$R_2 = (m_2 - m_1) R_m = (500 - 100) \times 100 = 40 \times 10^3 \Omega = 40 \text{ k}\Omega,$$

$$R_3 = (m_3 - m_2) R_m = (2500 - 500) \times 100 \Omega = 200 \text{ k}\Omega,$$

$$R_4 = (m_4 - 1) R_m = (5000 - 2500) \times 100 \Omega = 250 \text{ k}\Omega.$$

Procedure :

Connect as per the circuit diagram to a d.c. supply which measures maximum of 500 volts.

- 1) Connect R_1 in series to the meter and measure maximum full scale deflection is 10 V.
- 2) Connect R_2 in series to the meter and measure maximum full scale deflection is 50 V.
- 3) Connect R_3 in series to the meter and measure maximum full scale deflection is 250 V.
- 4) Connect R_4 in series to the meter and measure maximum full scale deflection is 500 V.

Result :

Given Ammeter is converted into Voltmeter in Four ranges through a rotatory switch by measuring 10 V, 50 V, 250 V and 500 V in Four positions of rotary switch.

Questions :

- 1) Convert given Ammeter into Voltmeter, Show the calculation taking into account case study as per available ranges in the laboratory.

2. STUDY AND USE OF ANALOG MULTIMETER

Aim :

To study and use of Analog Multimeter

Operettas Required :

An Analog Multimeter, Resistors, A.C/D.C Voltage, A.C/D.C Current measurement with the multimeter

Theory and Procedure :

Movement Protection Switch :

We have provided ON-OFF switch on the right side of meter case to short the movement which prevents the damage during transit.

Range of measurement:

DC Voltage	: 5V, 25V, 250V and 1000V
AC Voltage	: 5V, 25V, 250V, 500V and 1000V
DC Current	: 10mA 250mA
Resistance	: Range R x 1, R x 10, R x 100 and R x 1000
Battery	: Internal 1.5V Pencil Cell. (2Pcs.)

General Instructions :

1. At each measurement, confirm the range to be used.
2. When measuring an unknown voltage or current, always start from the highest range to know the approximate value. Then switch it down to the appropriate range to check accurate value.
3. By no means voltage should be measured on current or ohm range.
4. When zero ohm adjustment is ineffective on R x 1 range, the internal batteries are required to be replaced with fresh ones.
5. When the meter is not in use, set the selector switch on DC mA range.
6. Do not expose the Meter in high temperature or humidity.

Features :

1. Wide Range of Measurement : Through the internal the batteries (1.5V x 2). The meter measures resistance up to $1/M\Omega$ at maximum, while DC voltage range measure from 5v to 1000V at full scale.
2. The meter is available for checking all kinds of electronic instruments and radio sets as well as semi-conductors.

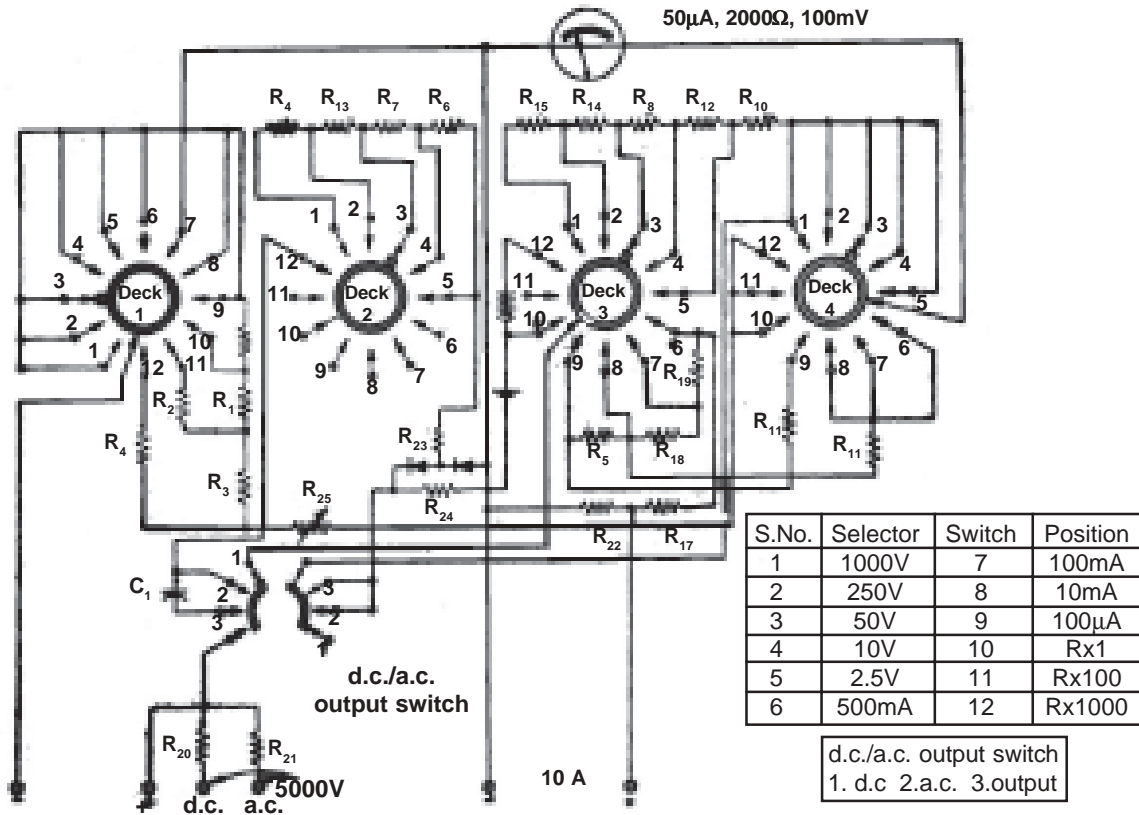

ANALOG MULTIMETER

Instructions for Use :

1. Range of measurement is divided into DCV, ACV, OHMS, DCmA and DCmA. all of which are switched over by means of the selector knob in the centre of the panel face.
2. The red test probe is connected to + jack and the black one to - jack respectively.

3. Measurement of DC Voltage.

- (a) The range selector switch is set at an appropriate DCV range connecting the test prods to their respective jacks.
- (b) When checking T.V., radio and communication apparatuses the black test lead is connected to the chassis which is -ve potential and the red test lead is applied to +ve potential is for measurement.
- (c) In case of special circuits such as oscillating circuit where negative potential is generated, the connection of the probes are reversed, the red one to the chassis and the voltage is checked by applying the black lead.
- (d) To measure transistor circuit P-N-P type, the probes are connected as indicated in (c) above. with N-P-N type transistor circuit, the connection is as indicate in (b).
- (e) Generally when measuring DCV circuit loaded with high resistance, indication will be a little lower than the actual value effected by the serial internal resistance of the meter movement. However, very high internal resistance of H-30 makes such indication error less compared with other testers.

- (f) To know current by measuring voltage is checked by applying the probes to both ends of the resistance to know the value dropped by the current. The value thus obtained is divided by the value of resistance, For Instance :-

$$\text{In case of the loads to be } 10\text{k}\Omega \text{ and the value indicated is } 50\text{V: } \frac{50\text{V}}{50\text{k}\Omega} = 1\text{mA}$$

High DCV Internal resistance and small current consumption of this model enables measurement of current without disconnecting the circuit, if the value or the current is known by measuring the voltage value dropped.

4. Measurement of DC μ A-mA.

- For current measurement the tester is always connected in series to circuit checked and the circuit measured is disconnected.
- The centre selector switch is set at an appropriate DC μ A-mA range.
- To measure, the red probe is applied to (+) potential and black point, to (-) potential of the circuit. If the pointer deflects to the left across the Zero point, just reverse the connections.

5. Measurement of Resistance

- The selector switch is set to an appropriate ohm range.
- The probes are shorted and the pointer of the meter movement is adjusted by means of "0" adjustment knob to rest on zero position on the right extremity.
- The resistance value is known by applying the red and the black probes each to both ends of the resistance of measure.
- The ohm value read on the scale indicates the resistance measured on R x 1 range. On the other ranges, the value indicated are multiplied by 10, 100 respectively as the case may be.

6. Measurement of AC Voltage :

AC Voltage ranges are mostly used to check the output voltage of power transformers or mains supply. Using a high quality midget copper oxide rectification.

- The selector switch is set at an appropriate range. Test probes used irrespective of polarity.
- Black AC Volt scale is used, The voltage value is obtained just in the same way as with measurement of DC Voltage.
- Frequency ranges used are approximately from 40 Hz to 50 Hz

7. Output Measurement :

The meter is Calibrated for full scale or 1 Volt at 8 Ω load. The range selector switch set at 5V AC and the probes at their respective jacks.

Result :

By using an Analog Multimeter measured resistance, A.C/D.C Voltage, Current in different ranges.

Questions :

- 1) Measure the A.C/D.C Voltage, Currents and Resistances with an Analog Multimeter.

3. STUDY AND USE OF DIGITAL MULTIMETER

Aim :

To study and use of Digital Multimeter

Operettas Required :

Digital Multimeter, Resistors, A.C/D.C Voltage, A.C/D.C Current measurement with the multimeter. Instead of pointer deflection in analog meter in digital meter an additional circuit is used to convert analog signal equilent decimal electrical signal and a LCD display is used.

A LCD display gives an accurate reading of the quantity measured in the display. There is no paralax error in measurements. Hence correct reading measure in the digital meters.

Theory and Procedure :**Movement Protection Switch :**

We have provided ON-OFF switch on the right side of meter case to short the movement which prevents the damage during transit.

Range of measurement:

DC Voltage	: 5V, 25V, 250V and 1000V
AC Voltage	: 5V, 25V, 250V, 500V and 1000V
DC Current	: 10mA 250mA
Resistance	: Range R x 1, R x 10, R x 100 and R x 1000
Battery	: Internal 1.5V Pencil Cell. (2Pcs.)

General Instructions :

1. At each measurement, confirm the range to be used.
2. When measuring an unknown voltage or current, always start from the highest range to know the approximate value. Then switch it down to the appropriate range to check accurate value.
3. By no means voltage should be measured on current or ohm range.
4. When the meter is not in use, set the selector switch on DC mA range.
5. Do not expose the Meter in high temperature or humidity.

Features :

1. Wide Range of Measurement : Through the internal the batteries (1.5V x 2, 9V x 1). The meter measures resistance up to 20 M Ω at maximum, while DC voltage range measure from 0V to 500V at full scale.
2. The meter is available for checking all kinds of electronic instruments and radio sets as well as semi-conductors, in industrial and domestic purpose.

Instructions for Use :

1. Range of measurement is divided into DCV, ACV, OHMS, DCmA and DCmA. all of which are switched over by means of the selector knob in the centre of the panel face.
2. The red test probe is connected to + jack and the black one to - jack respectively.

3. Measurement of DC Voltage.

- (a) The range selector switch is set at an appropriate DCV range connecting the test prods to their respective jacks.
- (b) When checking T.V., radio and communication apparatuses the black test lead is connected to the chassis which is -ve potential and the red test lead is applied to +ve potential is for measurement.
- (c) In case of special circuits such as oscillating circuit where negative potential is generated, the connection of the probes are reversed, the red one to the chassis and the voltage is checked by applying the black lead.
- (d) To measure transistor circuit P-N-P type, the probes are connected as indicated in (c) above. with N-P-N type transistor circuit, the connection is as indicate in (b).
- (e) Generally when measuring DCV circuit loaded with high resistance, indication will be a little lower than the actual value effected by the serial internal resistance of the meter movement. However, very high internal resistance of H-30 makes such indication error less compared with other testers.
- (f) To know current by measuring voltage is checked by applying the probes to both ends of the resistance to know the value dropped by the current. The value thus obtained is divided by the value of resistance, For Instance :-

In case of the loads to be $10k\Omega$ and the value indicated is 50V:
$$\frac{50V}{50k\Omega} = 1mA$$

High DCV Internal resistance and small current consumption of this model enables measurement of current without disconnecting the circuit, if the value or the current is known by measuring the voltage value dropped.

4. Measurement of DC μ A-mA.

- (a) For current measurement the tester is always connected in series to circuit checked and the circuit measured is disconnected.
- (b) The centre selector switch is set at an appropriate DC μ A-mA range.
- (c) To measure, the red probe is applied to (+) potential and black point, to (-) potential of the circuit. If the pointer deflects to the left across the Zero point, just reverse the connections.

5. Measurement of Resistance

- (a) The selector switch is set to an appropriate ohm range.
- (b) The resistance value is known by applying the red and the black probes each to both ends of the resistance of measure.
- (c) The ohm value read on the scale indicates the resistance measured on R x 1 range. On the other ranges, the value indicated are multiplied by 200, 20K, 200K, 20M respectively as the case may be.

6. Measurement of AC Voltage :

AC Voltage ranges are mostly used to check the output voltage of power transformers or mains supply. Using a high quality midget copper oxide rectification.

- (a) The selector switch is set at an appropriate range. Test probes used irrespective of polarity.
- (b) Black AC Volt scale is used, The voltage value is obtained just in the same way as with measurement of DC Voltage.
- (c) Frequency ranges used are approximately from 40 Hz to 50 Hz

7. Output Measurement :

The meter is Calibrated for full scale or 1 Volt at 8Ω load. The range selector switch set at 5V AC and the probes at their respective jacks.

4. STUDY AND USE OF AUDIO FREQUENCY OSCILLATOR

Aim :

To study and use of Audio Frequency Oscillator

Operettas Required :

Multi Meter, Audio Frequency Oscillator or Function Generator and Radio receiver connecting wires

Theory :

Function Generator circuit of a typical function generator. This instrument delivers sine, triangular and square wave shapes. The typical frequency range may be 20 Hz to 20 kHz. The signal generator is provided with frequency control network. The frequency control voltage regulates two current sources.

For the generation of a triangular waveshape, an integrator circuit is used as shown. The upper current source supplies a constant current and therefore the output voltage of tthe integrator.

It is clear from above that, the output voltage increases linearly with time.

The voltage comparator multivibrator is used to change state at a predetermined level on the positive slope of the integrator's output voltage. This cuts of the upper current supply and switches on the lower current supply. Since the direction of current supply from the lower source is in opposite direction to that of the upper current source, the output voltage decreases linearly with time till a change in state at a predetermined level is brought about by the voltage comparator multivibrator and the upper current source is switched on again. Hence we get a triangular waveshape. Since the slope of curve is determined by the magnitude of the current and therefore the frequency of the output voltage is also determined by the magnitude of the current. This triangular waveform is obtained at the output of the integrator.

A square waveform is obtained at the output of the multivibrator. The third waveform is obtained when the triangular waveform is synthesised with a sinusoidal waveform. Output amplifiers are used to amplify the signals.

Procedure :

Connect Audio test Oscillator in Audio frequency range input of the power amplifier stage. Give the Audio signal hear the click sound from the loud speaker. Repeat the procedure four times.

Result :

Audio test Oscillator 20 Hz to 20 kHz frequency responce is studied.

Questions :

1) Study the Audio test Oscillator.

5. STUDY AND USE OF AMSSG

Aim :

To study and use of AMSSG in Radio receivers

Operettas Required :

A standard AMSSG, Radio receiver and Connect wires.

Theory :

A standard AMSSG provides modulated and unmodulated R.F. signals in the frequency ranges most commonly required in the manufacture & servicing of radios & communication receivers.

The R.F. output level is continuously adjustable by means of attenuator system over the range of 1 micro volt to 100 milli volts.

The R.F. output can be modulated externally on internally by a built in AF Oscillator. The RF output can lower be obtained unmodulated.

The internal audio signals can also be accessible for external use, the output amplitude is controlled by an attenuator system.

Frequency Ranges:	50KHz	to	150 KHz
	150 KHz	to	420 KHz
	420 KHz	to	500 KHz
	500 KHz	to	1500 KHz
	1.5 MHz	to	5 MHz
	5 MHz	to	15 MHz
	15 MHz	to	550 MHz

RF output	Variable for $1\mu\text{v}$ to $100\mu\text{v}$ $\pm 6\text{db}$ $\pm 1\mu\text{v}$
-----------	--

Output Impedance	1 μv to 10 μv : 20 ohm 100 μv 40 Ω 1mv to 100mv - 300 Ω
------------------	--

Modulated level	30% \pm 10%
-----------------	---------------

AF Modulation	400 Hg
---------------	--------

Power Supply	230 Singer Phase 50 Hz ac
--------------	------------------------------

The important blocks of SSG are :

1. RF Oscillator
2. AF Oscillator
3. RF Buffer Amp & Modulator
4. Attenuator
5. Power Supply

The important characteristics & adjustments that can be done to a receiver are :

1. Sensitivity
2. Selectivity
3. Fidelity
4. Signal & Noise ratio
5. Image Rejection Ratio

1. Sensitivity :

It is the ability of the receiver to respond to the weakest signal possible. It is expressed as the input voltage required to give a standard output of 50 mW in case of low power receiver and 500 mW in case of high power receiver. Sensitivity can also be expressed in dB as the input voltage required below 1 volt.

2. Selectivity :

It is the ability of a receiver to distinguish between the wanted & unwanted signals.

It can also be defined as the ability of receiver to reject the unwanted signals.

3. Fidelity :

It is the ability of a receiver to reproduce the given input signal at its output without distortion. This is expressed as a curve. All receivers are designed to offer a band width of ± 5 KHz. Radio Frequency and Distortion Factor circuits.

4. Signal to Noise Ratio :

It is defined as the ratio of input signal and noise to the output signal & vice versa. It is also defined as the ratio of signal power to Noise Power at the output part of the receiver.

$$\text{Signal to Noise ratio} = \frac{S}{N} = \frac{E_s^2}{R} \div \frac{E_n^2}{R} = (E_s/E_n)^2$$

5. Noise Figure :

It is the ratio of signal to noise power supplied to the input of a receiver to the signal to noise power supplied to output of a load resistor.

Image Rejection Ratio :

It is the measure of the input required to get the same output as that of the wanted signal at the output of the receiver when it is given with an input at a image frequency.

Use of AMSSG for Radio Receiver Measurement of Sensitivity and Fidelity :**Aim :**

To determine the sensitivity of a radio receiver

Equipment Required :

AMSSG, Balun, Radio Receiver and Power output Meter

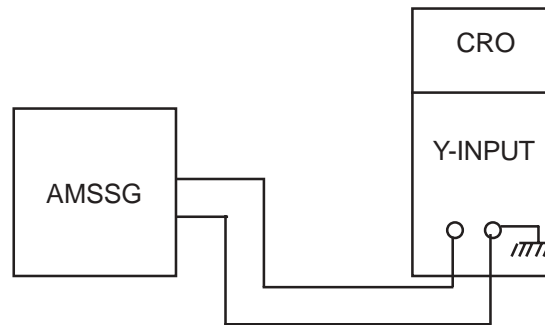
Block Diagram :**Practical Procedure :**

For obtaining sensitivity of a radio receiver. First the AVC/AGC should be disconnected and equipment is set up connections are made as shown in the figure.

- Select the radio receiver band to medium wave.
- Select 500 MHz from AMSSG to get a standard output of 50 mwatts at the output.
- Increase the signal input from 500 MHz in increments of 5KHz at each step of increase and note the narration of input levels to gave standard output of 50 mW in the power output meter.

The input frequency is received from 500 KHz to 600 KHz and a plot is plotted frequency Vs input level signal in μv and the least level of input is observed in the plot and this is observed as the sensitive frequency of the receiver.

Experiment :

To obtain the Fidelity of a radio receiver

Experimental set up : Block diagram

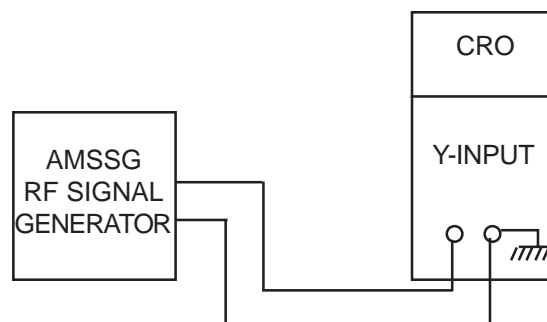

Experiment Procedure :

Set the AMSSG input to constant where a considerable output about 500 mW is available.

The experimental set up is connected as per the block diagram.

The radio receiver is switched in Medium wave Band. The AMSSG is set 1000 KHz from and modulation from 20 KHz to 100 KHz.

Frequency and note the corresponding output for each frequency V_{in} constant.

and a plot is plotted frequency Vs gain in the graph sheet.

Tabular Column

Sl.No.	Frequency	Input voltage in μv	Output constant at 50 mW
1.	500 KHz	6 μv	
2.	500 KHz	4 μv	
3.	600 KHz	2 μv	
4.	650 KHz	4 μv	
5.	700 KHz	5 μv	
6.	750 KHz	6.5 μv	
7.	800 KHz	9 μv	
8.	850 KHz	11 μv	
9.	900 KHz	13 μv	
10.	1000 KHz	15 μv	
11.	1050 KHz	17 μv	
12.	1100 KHz	22 μv	

Assessment :

1. Skill in Handling Equipment
2. Circuit Diagram and connection
3. Observations and taking readings
4. Graphs / Calculations
5. Viva

Result :

AMSSG and its use in radio receiver measurement of sensitivity, selectivity and fidelity is studied.

Questions :

1. Study the application of AMSSG in Radi Receiver Circuit to measure sensitivity, selectivity and fidelity.

6. STUDY AND USE OF DIGITAL LCR METER

Aim :

Study of Digital LCR Meter.

Equipment Required :

A digital LCR Meter, Different types of capacitors, Inductors, Resistors and connecting probes.

Theory :

Digital L.C.R Meter : To measure an inductance, capacitance, Resistance with the same meter, which reads decimal output is said to be digital LCR meter. A selector switch provided to measure a particular quantity.

Measurement of inductance : A simple coil “L” is loosely coupled to the output coil of a variable frequency oscillator. The dial of the oscillator is calibrated in terms of frequency. A variable capacitor, C is used for obtaining resonance conditions which is indicated by a decimal counter.

$$\text{At resonance } f_0 = \frac{1}{2\pi\sqrt{LC}}$$

Measurement of Inductance, capacitance with digital LCR Meter.

Thus knowing the value of frequency, of and capacitance, C, the value of the inductance may be calculated.

To measure inductance of the coil switch S is opened LC stand any capacitors one in resonance. The output of the signal is given to the input of the amplifier.

The amplifier increases the strength of the signal in sinewave. The output of the amplifier is given to the input of the schimatt trigger. The schimatt trigger gives the square wave output. The square wave output goes to start stop gate.

Now the signal goes to decade decimal counter to display decimal reading.

Measurement of Capacitance :

With switch “S” closed the circuit again in resonance to measure the capacitance of the capacitor. In this circuit for measurement of capacitance. “C” is the unknown capacitance connected in parallel with a variable standard capacitance Cs. The standard capacitance is of the same order as the unknown capacitance.

With switch open, resonance is obtained by varying the standard capacitance Cs.

At resonance

Now switch “S” is closed putting unknown capacitance in parallel with “Cs”. Keeping the frequency of the same as earlier, resonance conditions are obtained by varying “Cs”.

Cs2 = setting of standard capacitance with switch “S” closed.

Measurement of Resistance with digital LCR meter :

The effective resistance of a resonance of a resonant circuit can be measured by variation of reactance of the circuit.

In this circuit a thermistor is used to measure current through recording system. The circuit reactance is varied by either varying the value of capacitance “C” or the frequency “f”. The reactance is adjusted till the ammeter reads maximum value. This happens when the circuit is under resonance conditions.

Results:

With the help of Digital LCR Meter Resistance, capacitance, Inductance different values of in different ranges are measured.

Questions:

1. Study the given Digital LCR Meter, Measure the L,C,R different values and compare with indicated value.

7. MEASUREMENT OF DC AND AC VOLTAGE USING CRO

Aim :

Measurement of DC and AC voltage using CRO

Operettas Required :

CRO, AC Voltage source, DC voltage source and connecting probes.

Theory and Procedure :

In order to observe waveform on a CRO, the waveform of voltage under test is applied to Y plates and a voltage obtained from a sawtooth generator is applied to X plates. Let us assume that the sawtooth waveform has an idealized waveshape.

When simultaneously with the horizontal sawtooth voltage, an input voltage is applied to vertical deflection (Y) plates, the beam is under the influence of two forces : (i) one in the horizontal direction moving the beam at a linear rate from left to right, (ii) and second in the vertical direction moving the beam up and down. Since the deflection is proportional to the voltage applied to the deflection plates, the horizontal moement is proportional to the voltage applied to X plates at any instant and since the ramp voltage is linear it traces a straight line on the CRT screen. The vertical deflection is proportional to the voltage applied to the Y plates at any instant and thus the beam moves up and down according to the magnitude and polarity of the input voltage. The waveform displayed on a CRT tube due to an input sinusoidal voltage.

At the end of one sweep cycle, the sweep voltage abruptly drops down and the spot is immediately transferred to its original position. The process is then repeated again, with the result, that a stationary image is seen on the screen.

For the case shown the frequency of the input voltage is twice that of saw tooth voltage. To observe more than one cycle of the input voltage, the sweep voltages frequency has to be a submultiple of the input voltage frequency.

Measurement of A.C / D.C Voltage :

The expression for electronic deflection, given in that the deflection is proportional to the deflection-plate voltage. Thus the cathode-ray tube will measure voltage. It is usual to calibrate the tube under the given operating conditions by observing the deflection produced by a known voltage. Direct voltages may be obtained from the static deflection of the spot, alternating voltages from the length of the line produced when the voltages is applied to Y plates while no voltage is applied to X plates. The length of this line corresponds to the peak-to-peak voltage.

When dealing with sinusoidal voltages, the rms value is given by dividing the peak-to-peak voltage by $2\sqrt{2}$.

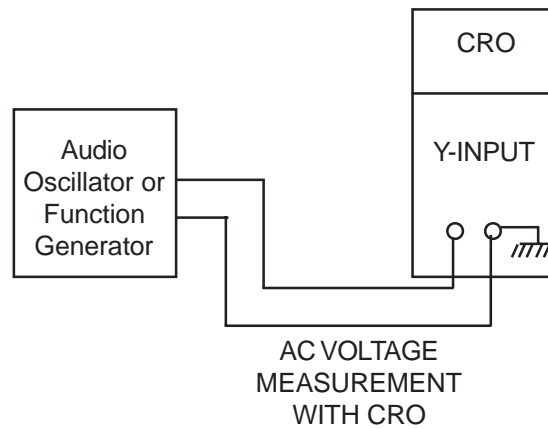
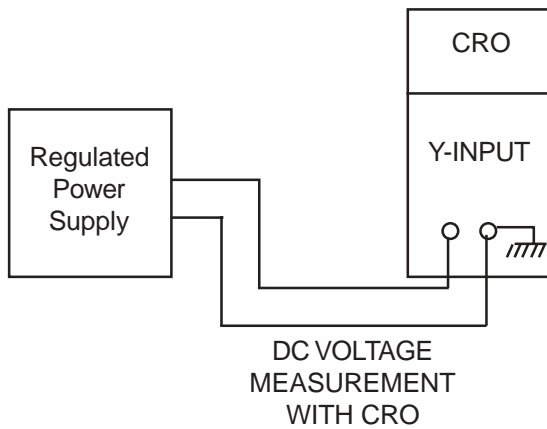
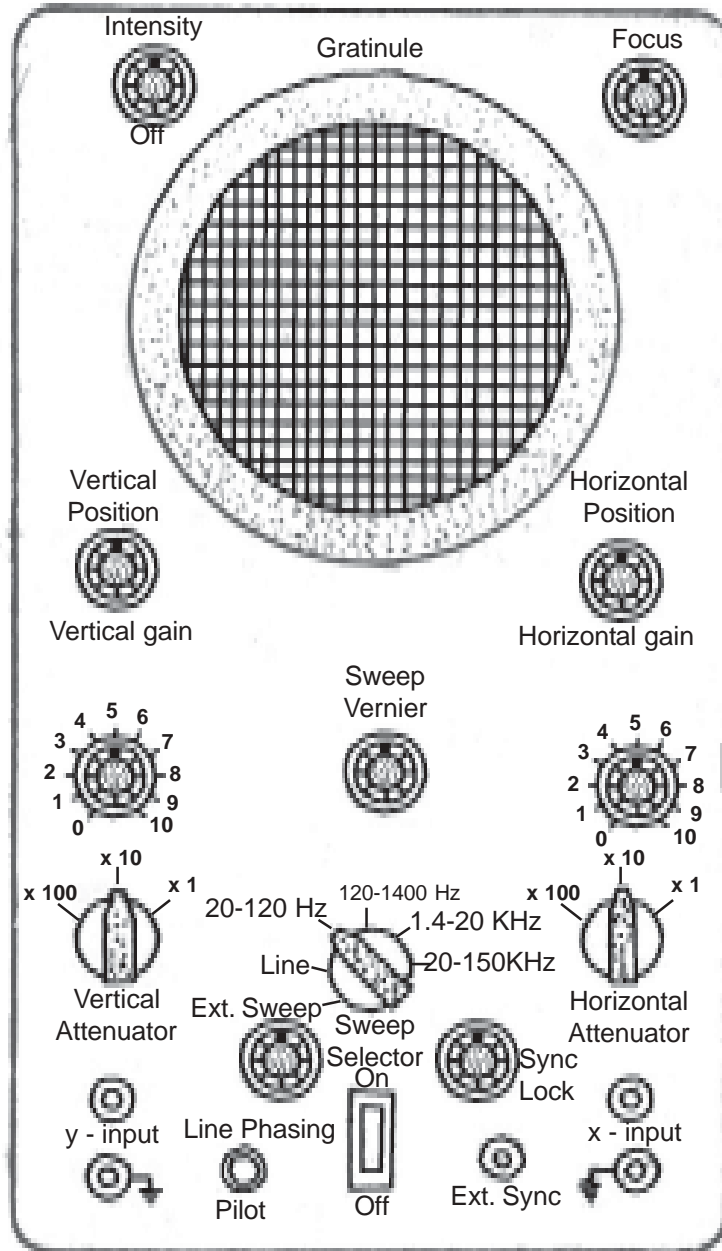

Laboratory oscillographs frequently incorporate voltage-measurement facilities by including constant-gain amplifiers and calibrated shift controls. The Y-shift control is adjusted so that positive peak of the test voltage coincides with some datum line on the screen; the shift control is then operated until the negative peak coincides with the datum. The movement of the control is arranged to read directly the peak-to-peak voltage. The value of a current can be obtained by measuring the voltage drop across a known resistance connected in the circuit.

Result :

A.C/D.C Voltages are measure with CRO

Questions :

- 1) Explain the procedure to measure A.C/D.C Voltages on the CRO.

8. MEASUREMENT OF FREQUENCY AND PHASE USING CRO

Aim :

To study measurement of frequency with the help of Lissazaous Figures and Phase.

Equipment Required :

CRO, AF Amplifier and Connecting Probes

Theory and Procedure :

Measurement of phase and Frequency :

The characteristics of patterns that appears on the screen of CRT, when sinusoidal voltages are simultaneously applied to horizontal and vertical plates. These patterns are called Lissajous Patterns.

(i) When two sinusoidal voltages of equal frequency which are in phase with each other are applied to the horizontal and vertical deflection plates, the patterns appearing on the screen is a straight line.

(ii) When two equal voltages of equal frequency but with 90° phase displacement are applied to a CRO, the trace on the screen is a circle.

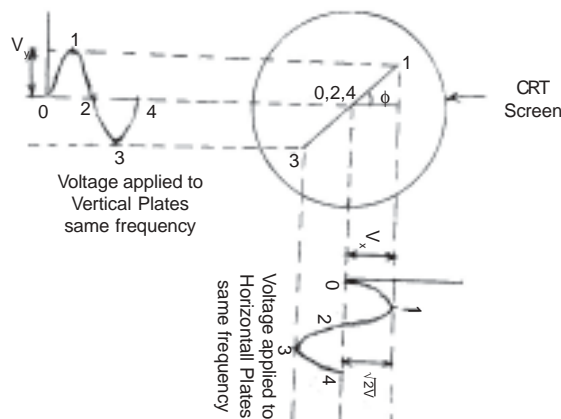

Lissajous pattern with equal frequency and zero phase shift

Fig 8.1

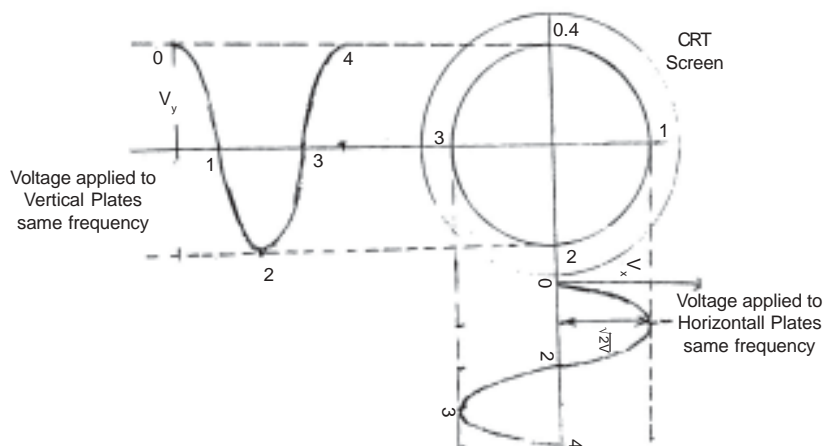

Lissajous pattern with equal frequency and a phase shift of 90°

Fig 8.2

When two equal voltages of equal frequency but with a phase shift (not equal to 0° or 90°), are applied to a CRO we obtain an ellipse. An ellipse is also obtained when unequal voltages of same frequency are applied to the CRO.

When two sinusoidal voltages of same frequency are applied the following observations.

(i) A straight line results when the two voltages are equal and are either in phase with each other or 180° out of phase with each other. The angle formed with horizontal 45° when the magnitudes of voltages are equal. An increase in the vertical deflection voltage causes the line to have an angle greater than 45° with the horizontal.

(ii) Two sinusoidal wave forms of the same frequency produce a Lissajous Pattern, which may be straight line, a circle an ellipse depending upon the phase and magnitude of the voltages.

A circle is formed only when the magnitude of the two signals are not equal and the phase difference between them is 90° or 270° . However, if the two voltages are not equal and are out of phase an ellipse is formed. If the Y voltage is larger, an ellipse with vertical major axis is formed. While if the X plane voltage has greater magnitude, the major axis of the ellipse lies along horizontal axis.

(iii) For equal voltages of same frequency progressive variations of phase voltage causes the pattern to vary from a straight diagonal line to ellipses of different eccentricities and then to a circle, after that through another series of ellipses and finally a diagonal straight line again.

Regardless of two amplitudes of the applied voltages the ellipse provides a simple means of finding phase difference between two voltages, the sine wave of the phase angle between the voltages is given by.

$$\sin \theta = \frac{Y_1}{Y_2} = \frac{X_1}{X_2} \quad (1)$$

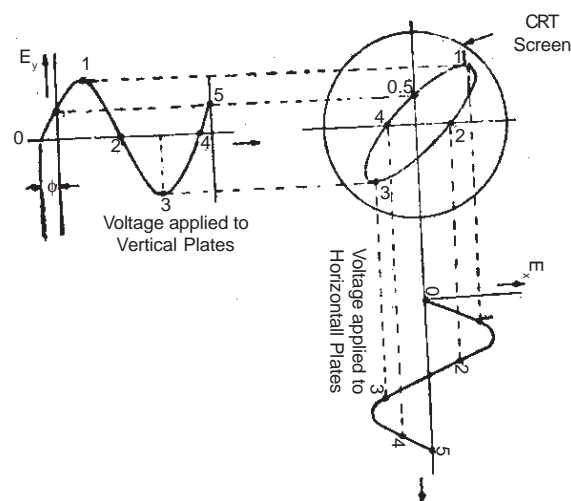

Lissajous pattern with two equal voltages of same frequency and phase shift of
Fig 8.3

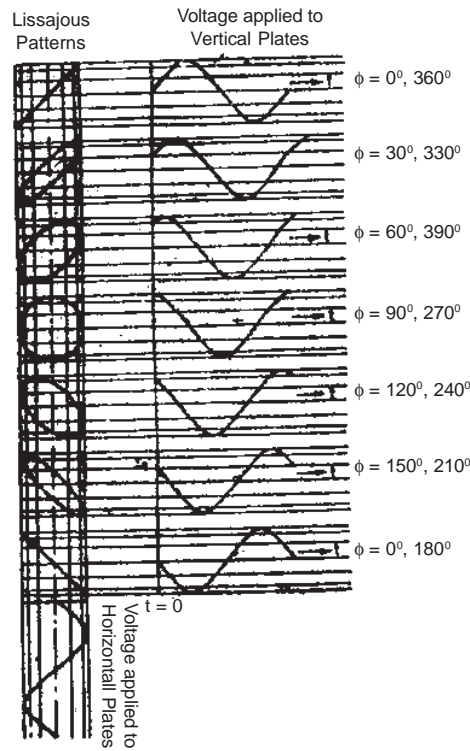

Lissajous patterns with different phase shifts
Fig 8.4

For convenience, the gains of the vertical and horizontal amplifiers are adjusted so that the ellipse tilts exactly into a square marked by the lines on the graticule.

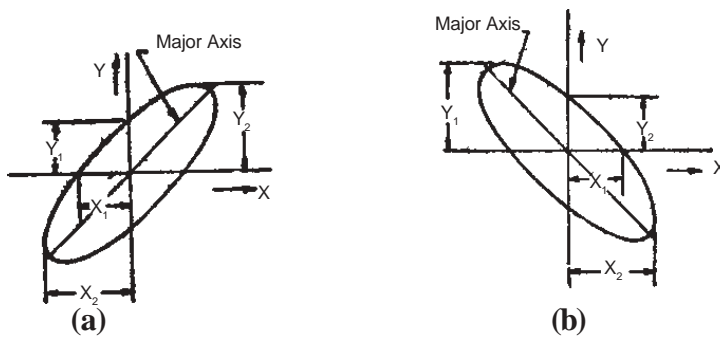

termination of angle of phase shift
Fig 8.5

Frequency Measurements :

Lissajous patterns may be used for accurate measurement of frequency. The signal whose frequency is to be measured, is applied to Y plates, An accurately calibrated standard variable frequency source is used to supply voltage to X plates, with the internal sweep generator switched off. The standard frequency is adjusted until the pattern appears as a circle or an ellipse, indicating that both signals are of the same frequency. Where it is not possible to adjust the standard signal frequency to the exact frequency of the unknown signal, the standard is adjusted to a multiple or submultiple of the frequency of the unknown source. So that the pattern appears stationary.

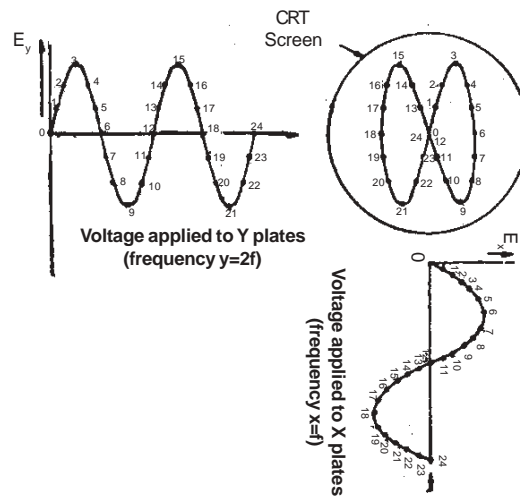

Lissajous pattern with frequency ratio 2:1
Fig 8.6

Let us consider an example suppose sine waves are applied to X and Y plates. Let the frequency of wave applied to Y plates is twice that of the voltage applied to X plates. This means that the CRT spot travels two complete cycles in the vertical direction against one in the horizontal direction.

The two waves start at the same instant. Lissajous Pattern may be constructed in the usual way and 8 shaped pattern with two loops is obtained. If the two waves do not start at the same instant we get different patterns for the same frequency ratio. The Lissajous patterns for other frequency ratio can be similarly drawn.

It can be shown that for all the above cases, the ratio of the two frequencies is:

$$\frac{f_y}{f_x} = \frac{\text{number of times tangent touches top or bottom}}{\text{number of times tangent touches either side}}$$

$$\frac{f_y}{f_x} = \frac{\text{number of horizontal tangencies}}{\text{number of vertical tangencies}}$$

Where f_y = frequency of signal applied to Y plates.
and f_x = frequency of signal applied to X plates.

Two lines are drawn, one horizontal and the other vertical so that they do not pass through any intersections of different parts of the Lissajous curve. The number of intersections of the horizontal and vertical lines with the Lissajous curve are individually counted. The frequency ratio is given by :

$$\frac{f_y}{f_x} = \frac{\text{number of intersections of the horizontal line with the curve}}{\text{number of intersections of the vertical line with the curve}}$$

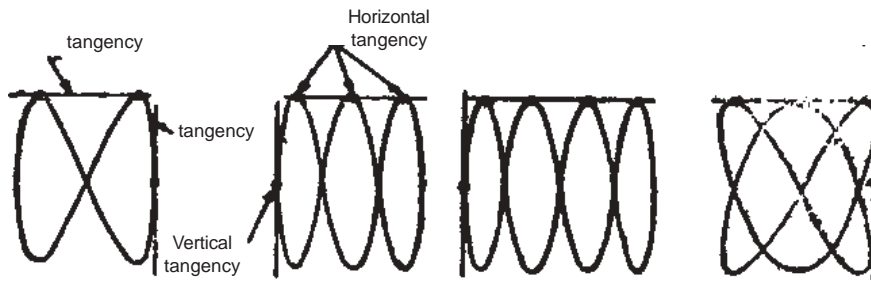

Lissajous patterns with different frequency ratios

Fig 8.7

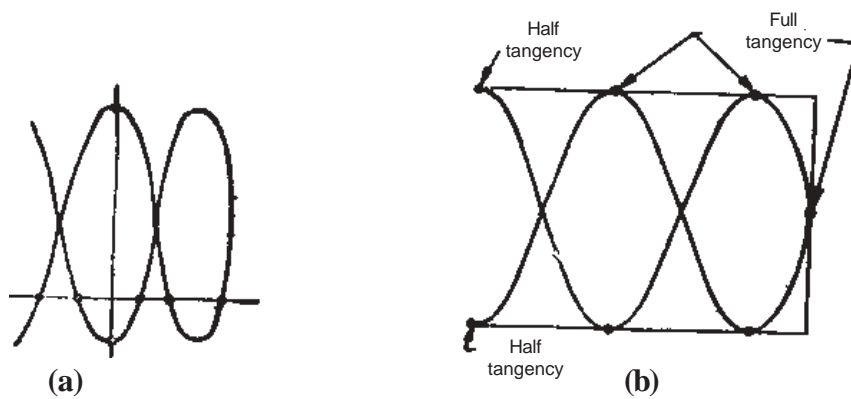

Fig 8.8

The applications of this rule 3.10 gives a frequency ratio

The modified rule is applicable in all cases whether the Lissajous pattern is open an closed.

$$\frac{f_y}{f_x} = \frac{\text{number of horizontal tangencies}}{\text{number of vertical tangencies}}$$

$$= \frac{2 + 1/2}{1} = \frac{5}{1}$$

$$\therefore f_y = 5f_x$$

Result :

Frequencies are measured by comparison methods in the form of Lissajous Figures and measured phase angle.

Questions:

- 1) Explain how do you measure frequencies with CRO.
- 2) How do you measure Phase difference with the help of CRO.

9. MEASUREMENT OF MODULATION INDEX USING CRO

Aim :

Measurement of Modulation Index using CRO

Equipment :

1. Cathode Ray Oscilloscope (CRO) (Dual or single trace)
2. Standard Signal Generator (SSG)
3. Regulator Power Supply (RPS Unit)
4. Audio Oscillator or Function Generator
5. Pulse Generator
6. CRO Probe

Theory and Procedure :

The Cathode Ray Oscilloscope (CRO) is very useful measuring instrument in laboratories & in research work. This instrument is used for display & measurement of various electrical parameters like ac or dc voltage time, frequency, phase relationships, risetime, fall time & indirect measurement of ac or dc current.

The heart of a CRO is its cathode ray tube (Circuit). To operate this Circuit the oscilloscope has a sweep oscillator, deflection amplifiers (horizontal & vertical), power supply circuit & a number of controls, switches & input terminals on the Front panel.

An electron beam produced by the electron gun in the Circuit strikes the fluorescent screen. As a result, a bright spot is observed on the screen of the Circuit. By applying voltages to the horizontal & vertical deflection plates, the beam is deflected in any desired direction.

To display a voltage wave it is connected to the vertical input of the scope. To the horizontal deflection plates a sawtooth wave voltage is applied internally.

If we connect sine wave voltages to both the vertical & horizontal inputs, we get a display called lissajous pattern. The shape of this pattern depends upon the frequency ratio of the two sinusoidal waves.

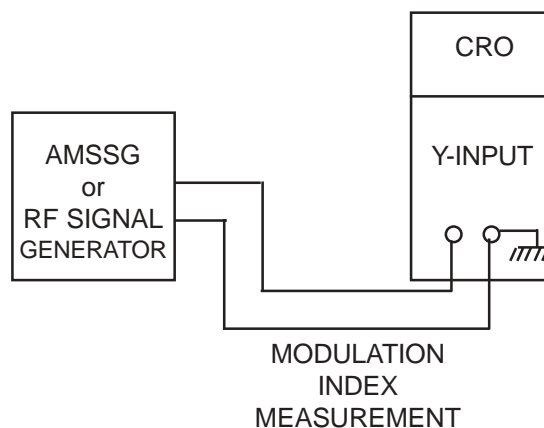

Modulation Index measurement:

1. Connect the output of the standard signal generator to the y-input terminals of the CRO.
2. The modulated signal is applied to the y-input terminals.
3. Adjust the sweep frequency to sub-harmonic frequency of the modulating frequency.

4. The depth of modulation $m = \frac{V_{\max} - V_{\min}}{V_{\max} + V_{\min}}$

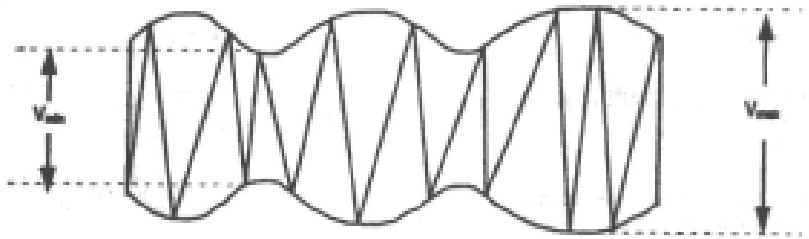

MODULATION INDEX MEASUREMENT ON CRO

Result :

Modulation Index with CRO.

Questions :

- 1) Measure the modulation index of AM wave?

10. STUDY AND USE OF PATTERN GENERATOR

Aim :

To study and use of pattern generator

Theory :

Block Diagram of pattern generator :

A pattern generator provides video signals, direct and indirect and with RF modulation, on the standard T.V channels for alignment, testing and servicing of T.V receivers. The output signal is designed to produce simple patterns.

- | | |
|------------------------|-------------------------------|
| 1. Chess board pattern | 2. Horizontal bars |
| 3. Vertical bars | 4. Corner chess board pattern |
| 5. Plain Raster | 6. Cross hatched |
| 7. Dot pattern | |

Block Diagram :

The block diagram of pattern generator as follows.

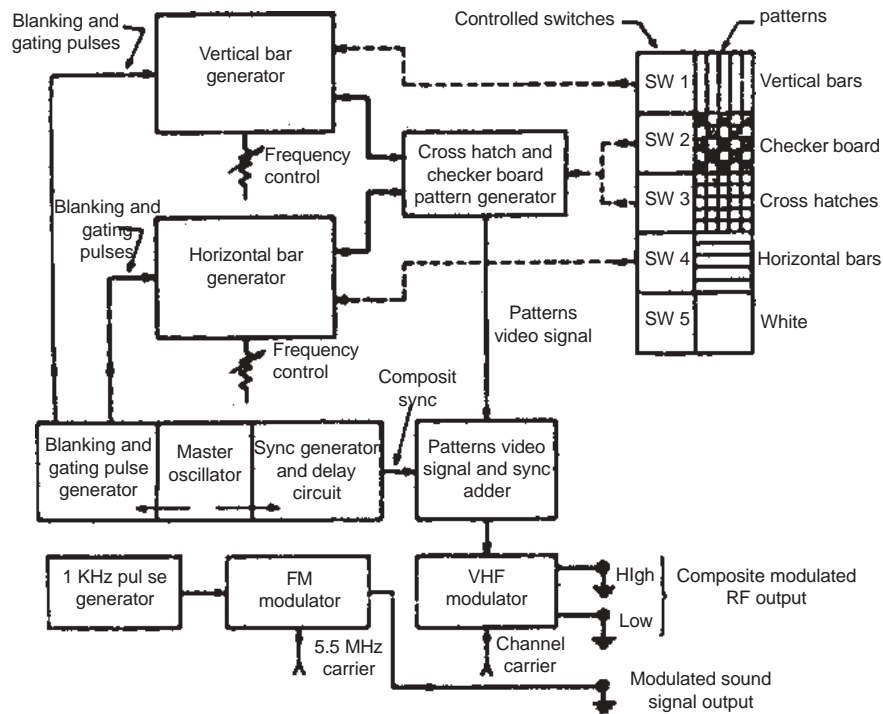

Simplified functional block diagram of a pattern-cum-sound signal generator

Fig 10.1

The pattern generator contains two stable chains of multivibrators, dividers and pulse shaping circuits, one below the line frequency to produce a series of horizontal bars and the other above 15,625 Hz to produce vertical bars. The signals are modified into short duration pulses which fed to the video section to the receiver. Along with the sync pulse train produce fine lines on the screen.

Output from the multivibrator produces square wave video signal at “m” times the horizontal frequency to provide vertical black and white bars. After every “m” cycles, the horizontal blanking pulses triggers the multivibrator for synchronizing the bar signal on each line. We can vary the number of bars of the front panel controls of the pattern generator by changing its frequency.

In the same way, square wave pulses derived either from 50Hz mains or from the master oscillators are used to trigger another set of multivibrators to generate square wave video signal that is “n” times the vertical frequency. When these are fed to the video amplifier they produce horizontal black and white bars. The switching rate of the multivibrator can be controlled by a potentiometer. It controls the number of B/W horizontal bars. The sync and blanking pulses are added to these signals prior to modulation.

A master oscillator is used to generate blanking and gating pulses and sync generation. The composite sync signal is given to the pattern video signal and sync adder. The output of vertical and horizontal bar generator goes to cross hatch and checker board pattern generator. The pattern video signal is given to the adder. From this adder the signal goes to the VHF modulation.

Amplitude modulation takes place over the carrier frequency of the channel selected and the composite modulated radio frequency output is available in high or low level from the output sockets. The master oscillator, sync generator and blanking generator supply the blanking pulses getting pulses to the multivibrators that generate vertical and horizontal bar signals.

A 1KHz audio oscillator generate a signal which is frequency modulated over a carrier of 5.5.MHz. This serves the purpose of the frequency modulated from the testing of the audio section. Its output is available over a separate socket marked as audio output sound signal.

The combination of switches mH and nV, the multivibrators generate different patterns.

Switch mH	Switch nV	Output pattern
OFF	OFF	Pure white raster
OFF	ON	Horizontal bars
ON	OFF	Vertical bars
ON	ON	Cross hatch.

The horizontal bar pattern is used for checking vertical linearity. The vertical bar pattern is used for checking horizontal linearity.

The cross hatch pattern is used for both linearity. Picture centering and aspect ratio. The dot pattern is suitable for checking and adjusting the static convergence of the picture in the centre of the screen with a low ambient brightness.

The white pattern, with no information is suitable for checking uniformity of brightness over the entire screen in the absence of hum.

Colour patterns are suitable for checking colour purity, proper colour reproduction and over all performance of the receiver. The test signals available with pattern generator are (1) RF signals (2) IF signals (3) Video signals.

Specifications of Pattern Generator :

Specifications :

Input power = 230 V/ 50Hz
Output power = 6 Watt
FM Carrier = 5.5 MHz
Internal signal = 1KHz sync wave

Test signals : Vertical bars
Horizontal bars
Chess board pattern
Cross hatch
Checker board
While - circle
on black back ground

RF output : 100 mV peak to peak

Contents : Line frequency, Video output, ON/OFF switch, RF socket
FM socket, Pattern selector switch, Control to change vertical or horizontal bars.

Procedure :-

1. Connect the pattern generator output to the T.V. receiver.
2. Switch on the pattern generator.
3. Set the T.V. receiver to the designed channel using band selector switch and channel selector switch.
Band I - Channels 2 to 4
Band III - Channels 5 to 12
4. Observe the different patterns on T.V. receiver and make necessary adjustments in T.V. receiver.

Result :

1. Checking the line and frame time bar linearity
2. Checking picture height and width
3. Checking video IF
4. Checking and adjustment of sound IF stage.
5. Checking of the AGC section
6. Trouble shooting video amplifier using variable video output.

Questions :

- 1) Study the given pattern generator and its use/applications.

11. STUDY OF BATTERY ELIMINATOR AND MEASUREMENT OF STANDARD VOLTAGES AT VARIOUS POINTS

Aim :

To study of Battery Eliminator and measurement of standard voltages at various points

Theory :

Battery Eliminator :

Almost all of the electronic equipments require d.c power supply for their operation. Even those equipments to which we provide a.c. mains supply, to convert ac supply in to d.c. Supply to various electronic circuits are used.

The battery eliminator are used for small power applications, such as radio receiver, emergency light charger etc.,

The battery eliminator circuit has got following blocks.

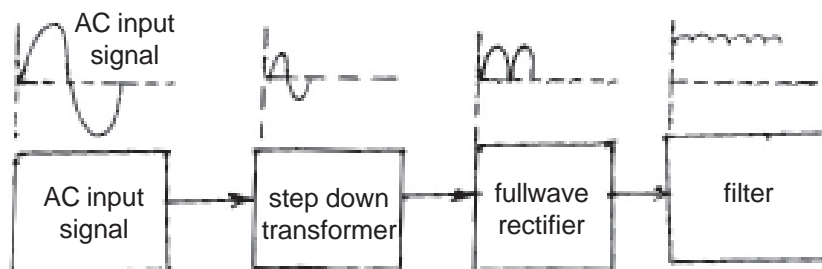

DC POWER SUPPLY BLOCK DIAGRAM

Fig 11.1

- i AC supply from mains
- ii. Step down transformer
- iii. Full wave rectifier
- iv. Filter.

i. AC Supply : A or ac supply line voltage is 230V/ 50 Hz.

ii. Step down transformer : The step down transformer is used to reduce or step down the ac supply to a low value. In this number of primary turns is more compare to number of turns in secondary. The supply obtained from secondary of the transformer is in the form of sine wave.

The transformer is a device which transfers ac power from primary to secondary at constant frequency.

iii. Rectifier circuit : By using semi conductor PN Junction diodes the supply in the form sine / square wave is rectified using this in form of pulsating either positive half cycles or negative half cycles.

The rectifier circuits are three types. They are as follows.

- (a) Half wave rectifier (By using single diode)
- (b) Full wave rectifier (By using two diodes)
- (c) Bridge rectifier (By using four diodes)

iv. Filter : In this circuit pulsating positive / negative half cycles are converted into smooth dc. supply.

By using an electrolyte capacitor the pulsating half cycles are filtered to get a d.c. supply. This dc. supply is got ripple.

Specifications of Battery eliminators

- Input ac. supply** : 230V / 50 Hz from mains.
- Output voltages** : 1.5V, 3.0V, 4.5V, 6.0V, 9V,12V, 15V, 20V d.c
- Current** : 100mA, 150mA, 200mA, 250mA, 300mA, 500mA, 1A, 2A.
- Ripple** : 41.2%, 121% for half wave rectifier
- Powers** : 100mW, 200mW, 250mW, 300mW, 500mW, 1W
- Input supply indicator:** a LED shows the ac. supply
- Out supply** : Indicates with LED supply position
- Fuse** : An ac fuse is provided

DC supply : Output dc supply is taken through proper probes with connectors/crocodile clips.

Voltage regulation : It is the ratio of difference of no load voltage to load voltage to no load voltage. Generally voltage regulation is denoted in percentage by multiplying by 100

$$= \frac{\text{No. load voltage} - \text{load voltage}}{\text{No. load voltage}} \times 100 \text{ voltage regulation.}$$

Applications :-

Battery eliminators are used for dc supply in radio receiver, tape recorder, battery charges for all domestic appliances. Atomic reactors, and small power requirements in electronic circuits.

Battery Eliminator Circuit working :-

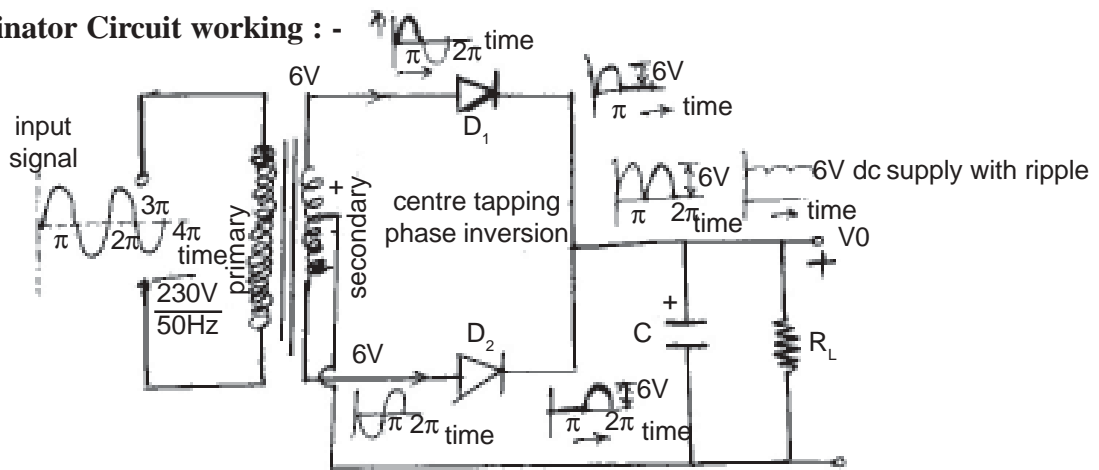

Fig 4.2

The battery eliminator circuit consists of the following components.

1. Step down transformer centre tapped. 6-0-6v.
2. Semi conductors diodes D1, D2 - IN4007
3. An electrolytic capacitor 1000 μ F/15V.
4. Load resistance $R_L = 600\Omega$

Step-down transformer :

The transformer used for this purpose is a step-down centre tapped transformer.

At primary of the transformer a.c main supply is given 230V/50Hz. The winding is so designed to get a secondary to get 6V. a.c. supply.

A centre tapped transformer is one which inverts polarity at tapping terminal i.e. if a positive pulse supplied to diode D1 and the same D2 is gets a negative pulse and there is a phase difference of 180°

Diode D_1 working :

As soon as a positive half cycle received by the diode D1. the D1 moves into forward bias mode in the time period $0-\pi$ seconds. As soon as a negative half cycle received by the diode D1 moves into reverse bias mode and there is no conduction between time period $\pi-2\pi$ in complete cycle of operation. This repeats in each cycle of operation.

Diode D_2 working :

As soon as the diode D2 receives the negative half cycle and it waves into reverse bias mode during the time $0-\pi$ seconds. As soon as a positive half cycles receives the D2 and it moves into forward bias mode and hence there is a conduction in time $\pi-2\pi$ seconds, in a complete cycle operation. This repeats in each cycle of operation.

At the ends two cathodes wave forms are added and get two positive half cycles in the operation in one complete cycle.

Capacitor C :

The capacitor charges positive half cycle and discharges through a capacitor. In the capacitor the positive half cycles are connected into a d.c. voltage with some ripple.

Resistor R_L :

This resistor consider as load resistance. On this resistance we get an output dc supply voltage.

S.No.	Transformer		Voltage on		DC voltage on C
	Primary Voltage	Secondary Voltage	D1	D2	
1.					
2.					
3.					
4.					
5.					
6.					

Result:

Battery Eliminator working is studied and measured voltages at various points mentioned above.

Questions:

- 1) Study the given battery eliminator measure the voltages at servicing points.

12. RECTIFY THE FAULTS IN BATTERY ELIMINATOR

Aim :

To study Faulty finding in Battery Eliminator.

Operettas Required :

Multimeter, Soldering Rod, Lead, Paste and servicing tools.

Theory and Procedure :

Faults in the Battery Eliminator :

The following faults can be identify during servicing of Battery Eliminator.

1. Loose connections between components.
2. Fuse burning
3. Power chord may be faulty
4. Transformer may be faulty
5. Diodes may be faulty
6. Capacitor may be faulty.

Rectification Procedure:

Open the cabinet and observe the physical position of inter connections between cabinet to circuit and circuit connections on the PCB. The rectification procedure involves in three steps they are

1. Visual checkup
2. Resistance analysis
3. Voltage analysis

1. Visual Checkup:

Now see the Physical position of the circuit and inter connections. If dust is form and the circuit inside the cabinet. With the help of electrical blower pump the air inside the cabinet. Now all the dust goes in the air and the circuit and cabinet appears cleanly. Now see the physical connections of the wires. If any wire is found disconnected connect it properly.

Now give the AC supply to the battery eliminator circuit and check transformer primary, secondary AC voltages and also measure DC voltage on capacitor. If voltages are measured as per the circuit condition. Then the battery eliminator is found OK. Otherwise with the help of multimeter go for second test resistance analysis.

2. Resistance Analysis:

Keep the multimeter in low resistance range. Switch of the power supply and check the continuety of transformer primary, secondary, center tab to diodes cathodes and finally check the continuety on capacitor.

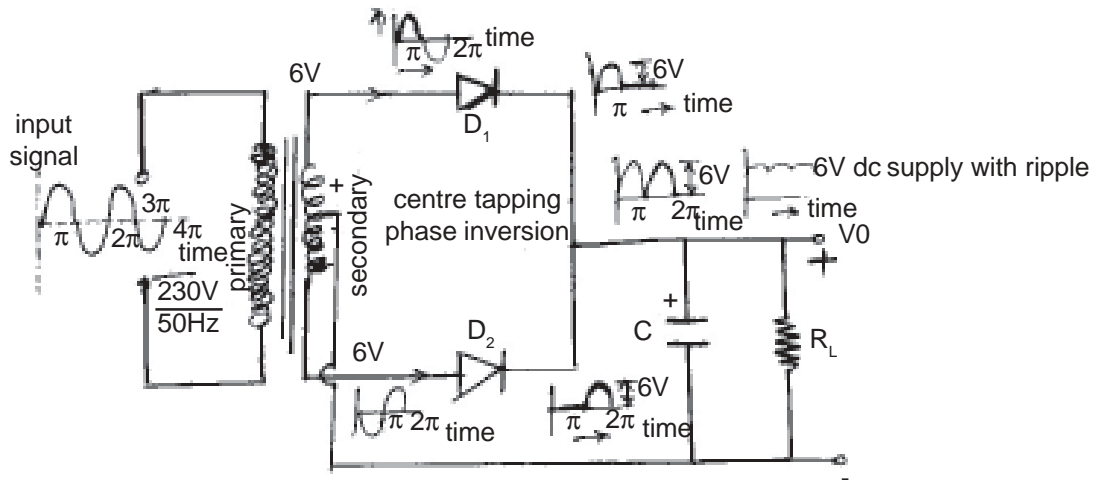

If above continuity point properly then the circuit is in working condition. Otherwise if any component found open or shorted replace new one and repeat the process while giving AC main supply to the Battery Eliminator.

3. Voltage Analysis:

Measurement of AC Voltage :

1. AC Voltage is measured at transformer primary and secondary at two tapping terminal positions.
2. DC Voltage is measured on capacitor.

Above two voltages are as per specifications then the battery eliminator problem is rectified.

S.No.	Transformer		Voltage on		DC voltage on C
	Primary Voltage	Secondary Voltage	D1	D2	
1.					
2.					
3.					
4.					
5.					
6.					

Result:

Electronic faulty equipment servicing procedure visual checkup, resistance analysis and voltage analysis is follow to rectify the problem in battery eliminator.

Questions :

- 1) Given Battery Eliminator output is 0 V. How do you checkup the battery eliminator write procedure.

13. STUDY OF ELECTRONIC STABILIZER AND MEASUREMENT OF STANDARD VOLTAGES AT VARIOUS POINTS

AIM:

To study of Electronic Stabilizer and Measurement of standard voltages at various points.

Equipment Needed:

Stabilizer Kit, Servicing Tools and Instruments,

Theory:

Block diagram of electronic stabilizer :

An electronic voltage stabilizer consists of the following blocks.

They are

1. Regulated dc power supply
2. Voltage level sensor
3. Voltage comparator
4. Relay driver
5. Relay chatter preventor and Hysteresis.

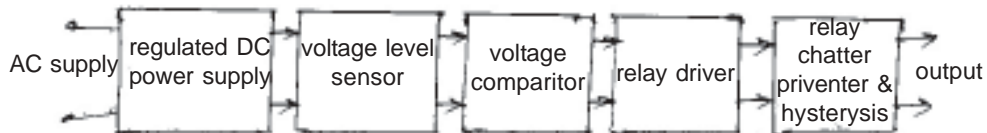

Regulated dc power supply :

A dc power supply consists following components.

- step down transformer
- Rectifier circuit
- Filter circuit
- Regulator circuit

(i) A **step down transformer** is used to reduce 230V ac supply to a low ac voltage

(ii) **Rectifiers are three types**

- Half wave rectifier
- Full wave rectifier
- Bridge rectifier

The rectifier circuit is used to rectify ac voltage in to pulsating positive / negative half cycle in specified periodic time / cycle.

(iii) **Filter** : The pulsating positive / negative half cycles are filtered by an electrolytic capacitor with appropriate value of capacitance. The capacitors converts it in to smooth dc voltage with some ripple.

The filters circuits are following types capacitor filter

T Filter

TT Filter

(iv) Regulator : This circuit gives constant dc voltage output from regulator circuit. The regulators are three types.

Zener voltage regular

Shunt regulator

Series regulator

Specifications of Electronic stabilizer:

Input : AC mains voltage 230V/50Hz. Variations in supply voltage - 10% tolerance
= 207V - 253V

Output supply : 230V/50Hz

Current rating : 250mA, 0-5A, 1A, 2A

Comparator using op-Amp

Op-Amp as an inverted comparator

CMOS comparator

Relay Drivers

Relay drivers with inverter

Schmitt trigger.

Simple Electronic stabilizer:

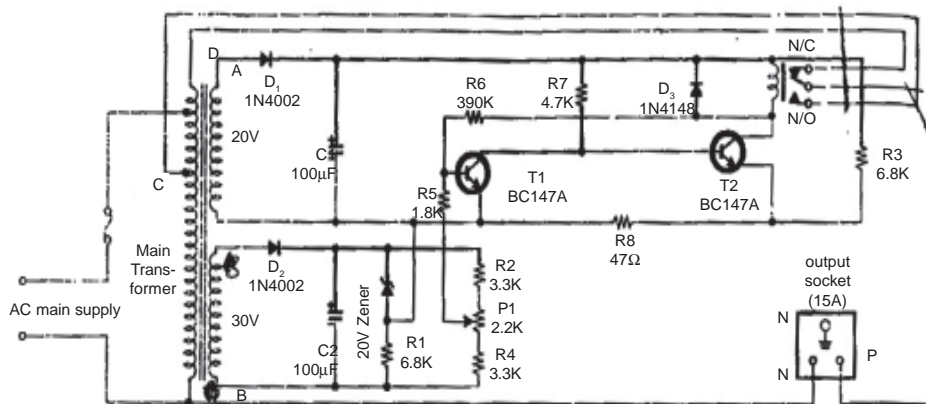

The above figure shows the circuit of automatic electronic voltage stabilizer using separate sensor and relay driver winding

In this circuit a separate winding is used 20V for relay driving and 30V winding for supplying the various input voltages to the sensor circuit.

In this circuit the auto transformer has four tappings A,B,C,D. The input is supplied between point B and D through ON/OFF switch and fuse. The output is taken either between point A and D or between point C and D.

When the output is taken from point A, the output transformer operates as step-up transformer. When the output taken from point C the auto transformer operates as step-down transformer.

The common from input supply is connected to common of auto transformer point D and to the common of output socket. This automatic stabilizer has limited range but still it is useful as it covers the sufficient range for operating devices.

This circuit consists of separate winding 20V used to supply the voltage proportional to the varying mains supply to the sensor circuit and to drive the relay which in turn changes the output.

The pole of the relay is connected directly to the phase of the output socket, the common connected pin N/C of the relay is connected to the point A of auto transformer, the other end is connected to point C of auto transformer.

The main components of sensor circuit are a rectifier diode D2, filter capacitor C2, potential divider formed by R1, R2 and P1 and Zener diode Z1 for comparison of changing input voltage. The driver consists of rectifier diode D1 to rectify the input from driver winding of 20V, filter capacitor C1, two NPN transistors BC 147A for switching and the relay connected to the collector of transistor T2.

The positive feedback to the base of transistor T1 from collector of Transistor T2 through resistor R6 is used for high switching and to maintain the stability. The potentiometer P1 is used to set the limit of maximum voltage.

Under normal operating conditions the transistor T1 is ON. The relay is in de-energized state pole connected to N/C and the auto transformer as the output is taken from the tapping A.

When the input voltage is more than the pre-determined level set by potentiometer P1. The transistor T1 switches OFF and in turn switches ON the transistor T2. This energizes the relay connected to N/O or O/C pin. The output is taken from the tapping "C" auto transformer which operates as step-down transformer.

The diode D3 connected in parallel to the relay is used to eliminate the back emf. The potential divider formed by resistor R3 and R8 are used to raise the emitter voltage and to make sure that both the transistors switch alternately.

S.No.	Transformer		Output Voltage on Socket
	Primary Voltage	Secondary Voltage	
1.			
2.			
3.			
4.			
5.			
6.			

Result:

Electronic stabilizer kit is studied measured input and output voltages.

Questions :

- 1) Study the given electronic stabilizer kit, measure the input output voltages.

14. RECTIFY THE FAULTS IN ELECTRONIC STABILIZER

Aim :

To find out the faults in given stabilizer.

Operettas Required :

Multimeter, Soldering Rod, Lead, Paste and servicing tools.

Faults in electronic Stabilizer :

The following faults were observed in stabilizer.

1. Burning fuse for short circuits
2. Failure of regulated power supply
 - Transformer failure
 - Diodes failure
 - Filtering capacitors failure
 - Failure in regulating circuits
3. Failure of voltage level sensors.
4. Failure of voltage comparator
5. Failure of relay and relay drivers

Rectification Procedure:

Open the cabinet and observe the physical position of inter connections between cabinet to circuit and circuit connections on the PCB. The rectification procedure involves in three steps they are

1. Visual checkup
2. Resistance analysis
3. Voltage analysis

1. Visual Checkup:

Now see the Physical position of the circuit and inter connections. If dust is form and the circuit inside the cabinet. With the help of electrical blower pump the air inside the cabinet. Now all the dust goes in the air and the circuit and cabinet appears cleanly. Now see the physical connections of the wires. If any wire is found disconnected connect it properly.

Now give the AC supply to the battery eliminator circuit and check transformer primary, secondary AC voltages and also measure DC voltage on capacitor. If voltages are measured as per the circuit condition. Then the battery eliminator is found OK. Otherwise with the help of multimeter go for second test resistance analysis.

2. Resistance Analysis:

Keep the multimeter in low resistance range. Switch of the power supply and check the continuety of transformer primary, secondary, center tab to diodes cathodes and finally check the continuety on capacitor.

If above continuity point properly then the circuit is in working condition. Otherwise if any component found open or shorted replace new one and repeat the process while giving AC main supply to the Battery Eliminator.

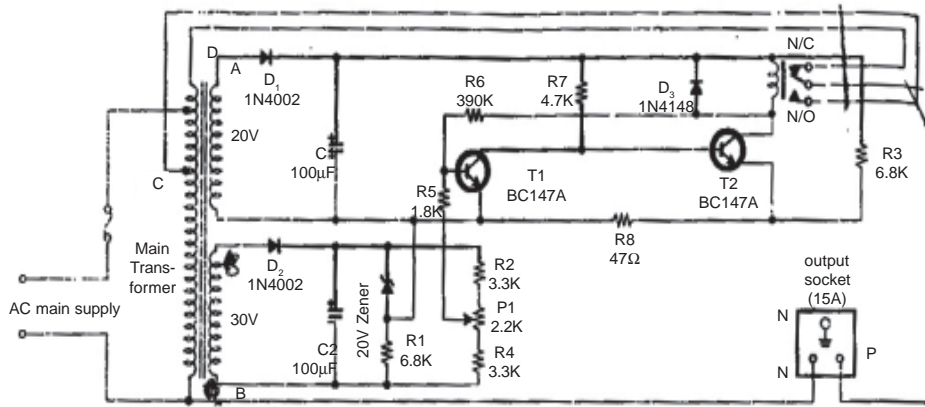

3. Voltage Analysis:

Measurement of AC Voltage :

1. AC Voltage is measured at transformer primary and secondary at two tapping terminal positions.
2. DC Voltage is measured on capacitor.

Above two voltages are as per specifications then the battery eliminator problem is rectified.

Result:

Electronic faulty equipment servicing procedure visual checkup, resistance analysis and voltage analysis is follow to rectify the problem in Electronic stabilizer.

Question :

- 1) Rectify the faults in electronic stabilizer.

15. STUDY OF EMERGENCY LIGHT AND MEASUREMENT OF STANDARD VOLTAGES

Aim :

Study of emergency light and measurement of standard voltages.

Operettas Required :

Multimeter, Soldering Rod, Lead, Paste and servicing tools.

Thoery :

The emergency light block diagram consists of four blocks. They are

1. Battery changing circuit from a.c. mains.
2. Battery Rechargeable
3. Trans starised oscillator
4. Table

Emergency light block diagram.

Battery charging : The battery charging circuit consists of a full wave rectifier with capacitor filter gets dc voltage to charge the battery 6V. The components used for this purpose is

1. A step down transformer 6V-0-6V.
2. Diodes In 4007 - 2 No.s
3. Electrolyste capacitor C =
4. Battery changing switch - S1

When S1 is closed rectified and filtered voltage comes to the rechargeable battery.

Battery : Every rechargeable battery posses battery ratings i.e. AH. This AH (ampere hour) rating indicates the capacity of the battery. Generally 3.5 AH to 6AH are indicated on the rechargeable battery and which provide illumination 30 minutes to 1 hour.

Transistorised oscillator : A weigh bridge oscillator is used to get standard sustained oscillations. The standard oscillations when switch S2 is closed goes to primary of the step - up transformer. The step up transformer output is given to a fluroscent tube orbulb to gave illumination ac supply from mains fails.

Specifications of emergency light : The emergency light specifications as follows.

Power rating : 2W, 4W, 6W, 8W, 10W, 20W and 40W

Battery types : Rechargeable battery with Ampere hour ratings 2.5AH, 4AH, 4.5 AH, 5AH, 6AH more AH rating gives the more time illumination.

Transformer : 6V-0-6V a cnetre tapped transformer

Current ratings : 200mA, 300mA, 500mA, 1A for charging

For connected at load it is a step-up transformer as per design requirement of power..

Transister : 2N3055 or any other equivalent used as an oscillator.

Switch : S1, S2
S1 is 5A switch
S2 is 2A switch

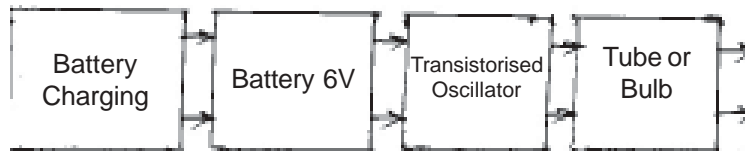

Indicators : Charging, discharging a seperates LED's are arranged to show charging from ac. mains, main fails discharging to gave illumination.

Tube Holders : Asper design based power rating

Cabinet : This is assembled in a cabinet made from plastic

Results : Emergency light circuit, operating controls, standard voltages are studied.

Standard voltages are input supply voltage 230 V AC , Battery eliminator output 6 V DC. oscillator output voltage 6 V AC step up transformer output 100 to 150 V AC. at tube light.

Questions :

Study the given emergency light block diagram and identify the standard voltage ?

16. RECTIFY THE FAULTS IN EMERGENCY LIGHT

Aim :

To study faults in emergency light.

Operettas Required :

Multimeter, Soldering Rod, Lead, Paste and servicing tools.

Thoery :

Faults emergency light rectification

1. Battery charging circuit may fails
2. Battery weaken
3. Inverter circuit fails
4. Failure of tube i.e. burns

1. Visual Checkup:

Now see the Physical position of the circuit and inter connections. If dust is form and the circuit inside the cabinet. With the help of electrical blower pump the air inside the cabinet. Now all the dust goes in the air and the circuit and cabinet appears cleanly. Now see the physical connections of the wires. If any wire is found disconnected connect it properly.

Now give the AC supply to the emergency light circuit and check transformer primary, secondary AC voltages and also measure DC voltage on capacitor. If voltages are measured as per the circuit condition. Then the battery eliminator is found OK. Otherwise with the help of multimeter go for second test resistance analysis.

2. Resistance Analysis:

Keep the multimeter in low resistance range. Switch of the power supply and check the continuety of transformer primary, secondary, center tab to diodes cathodes and finally check the continuety on capacitor.

If above continuety point properly then the circuit is in working condition. Otherwise if any component found open or shorted replace new one and repeat the process while giving AC main supply to the Battery Eliminator.

3. Voltage Analysis:

Measurement of AC Voltage :

1. AC Voltage is measured at transformer primary and secondary at two tapping terminal positions.
2. DC Voltage is measured on battery.

Above two voltages are as per specifications then the battery eliminator problem is rectified.

Result:

Electronic faulty equipment servicing procedure visual checkup, resistance analysis and voltage analysis is follow to rectify the problem in emergency light.

Questions :

Find out the fault in given emergency light.

17. FAMILIARIZE WITH LANDLINE TELEPHONE, CORDLESS TELEPHONE, CELLPHONES

Aim :

To study operating controls Landline Telephone, Cardless Telephone and Cell phone.

Equipment Required :

Landline Telephone, Cardless Telephone and Cell phone.

Theory :

Comparisons, Telephone land line, cardless telephone and cellphone

Land line telephone	cardless telephone	cellphone
Main control exchange telephone lines are distributed	card less telephone can be operated 50 metres distance from its control point	Main control from station it operates without any wire
No battery is needed it is got superate dc supply	Needs seperate chargeble cell	Needs battery chargeble type
Not portable	From telephone receiver 50m around can talk.	portable any where we can talk
Telephone relay	IC based system is used	Microprocessor based system.

Telephone Transmitter : It is a system in which sound evanes are converted in electrical signals. Then the signal is further processed.

Telephone receiver : It is a device in which electrical signal is converted in to sound signal and information is communicated.

Telephones tones : Dial tone, ring tone, engage tone, number unobtainable tones.

Electronic private automatic branch exchange : It is a main unit in which number of lines of telephones can perform.

Intercom : It is an internal communication system with in a college, office, factory, hotels. It is a short distance communication system.

Tones in Telephone Exchange:

The various tones used in telephone exchange as follows:

1. Dial tone
2. Ring tone
3. Busy tone / engage tone
4. Number unobtainable tone

Dial tone : This tone is returned to the calling subscriber from the first group selector and indicates that the exchange is ready to accept dialling from the subscriber. thus a subscriber must first hear the dial tone, and then start dialling. More often by the time, the subscriber lifts his handset and brings it near his ear, the dial tone is returned from the exchange. The dial tone stops as soon as the first digit is dialled. It is a continuous tone of 33Hz.

Ring tone : This tone is returned to the calling subscriber from the final selector when the bell of the called party's telephone is ringing. It stops as soon as the called party answers by lifting his handset. It is an interrupted tone of 133Hz interruption as follows.

0.4 seconds on 0.2 seconds off, 0.4 seconds on 2 seconds off and so on.

Busy tone : This tone is returned to the the calling subscriber from the final selector when the called party is engaged. This tone also sent from any of the group selector stages, when the particular group selector fails to find out free selector of the next stage, and steps to the 11th contact of the level. The tone stops only when the calling subscriber replaces his handset. It is an interrupted tone of 400 Hz with interruptions as follows.

0.75 sec on, 0.75 sec. off, and so on

Number unobtained tone : This tone is returned to the calling subscriber from the final selector when the called party's line is out order or disconnected or not available for some other reason. It is a continuous tone of 400Hz.

Result:

landline, cordless and cell phones operating controls, tones and comparisons are studied.

Questions :

Explain the comparisons of landline, cordless and cell phones operating controls and maintenance.

18. IDENTIFY THE DIFFERENT STAGES OF OPERATING CONTROLS, OF DVD PLAYER

Aim :

Identify the different stages of operating controls, DVD player.

Equipment Required :

A DVD player, A colour T.V. Receiver, VCDs and connecting probes.

Theory :

The DVD player has six main sections. They are:

- 1) Power supply sector
- 2) Disc Drive & Lens Unit.
- 3) Logic Card
- 4) Audio Amplifier Section
- 5) Front Panel & Display
- 6) Back Panel.

Choose appropriate Video Connection from DVD Player to TV Receiver following Methods:

Stereo Audio : Connect to the left/ right audio inputs of your TV Set.

Composite Video: This connection is popular, you can find the composite video input jack on the back panel of most TV set. With this connection, Video Setup should be set to OFF in the VIDEO menu.

Component Video: COMPONENT connector is one of video standards in America and China. It can offer the best picture quality, and it can still transmit progress scan signal. To finish this \ connection you must connect the unit and TV set by using three cables, and each of component video jacks had been marked as Y/Pb/Pr(Y/Cb/Cr). Please connect them one to one correctly. With this connection, Video Setup should be set to YUV in the VIDEO menu.

S-Video: A TV set usually support composite video or s-video input, but s -video connection can offer better picture quality than composite video connection. With this connection, Video Setup should be set to OFF in the Video menu.

VGA OUT: Generally , the D-Sub connector is widely used to transmit the progressive signal for computer; this connection will keep the picture best quality. The latest display monitor such as PDP, Progressive Scan TV set, and Projector can support this connection.

Audio Components:

Channel Audio: Connect 5.1 channels audio output of the unit and corresponding input of amplifier by 5.1 channels audio cable, please set "OFF" mode in "Speaker setup page"

Stereo Audio: Connection to the left / right audio inputs of your TV set, or 2 -channel analog amplifier. With this connection, all Analog out options should be set to 2 channels mode: LR / RT.

Setup Menu Categories:

TV Display: Depending on the type of television you have, you may want to adjust the screen setting (aspect ratio)

Normal / PS: You can see central portion of the Anamorphic wide screen picture on 4.3 TV. The extreme left and right side of movie picture will be cut off.

Normal / LB: You will see the total Anamorphic wide Screen picture on 4.3 TV, but black bars will appear at the top and bottom of the screen

Wide: Select it if you are connecting the player to a wide screen TV set. However, DVDs recorded with 4.3 ratio cannot be viewed as the full 16.9 picture even if you made this setup.

Angle Mark: Set it on: When playing multi-angle DVD disc, a logo like 1/2 will be shown automatically on top right TV screen, it means that the DVD you are playing has two angles and you are watching the first angle, you can change viewing angle by pressing ANGLE button on remote control.

Set it off: The player will not display the angle mark, though you are playing multi-angle DVD disc.

Captions: Set it on: Make sure that the DVD disc you are playing has captions on it, and change your colour system of TV to NTSC, then a caption may be shown on TV screen, or not, because a few TV sets can support display captions.

Set it off: Disable the function, caption will not be shown.

Notice: It is quite different from subtitle, subtitle is used to explain the vocal, and captions not only explain it but also give you more information about film. It is very useful for deaf people.

Speaker setup: The unit can mix a multi-channel sound to encode a two-channel sound, it's called downmix.

LT/RT: For Dolby Pro Logic Surround stereo sound output. It is a matrix encoding process enabling stereo soundtracks to carry four channels of audio information - left, centre, right and surround

Front Speaker / Centre Speaker / Rear Speaker / Sub woofer: If the DOWNMIX mode is tuned OFF, then select how you want your front speakers or rear speakers or center speakers to be set; either to small (standard setting) or to large. Large means that Bass & Treble audio is sent to the speakers. Small means only Treble audio is sent to the speaker.
you can also switch OFF the centre speaker, the Rear / L/R surround speakers and subwoofer.



FRONT PANEL CONTROLS OF DVD PLAYER

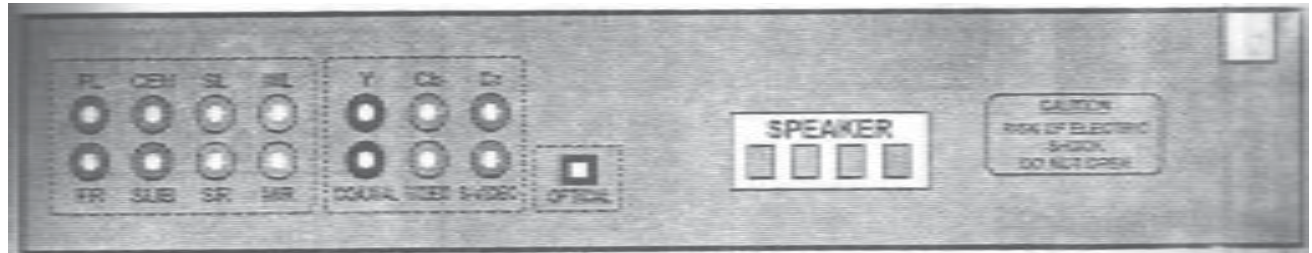

REAR PANEL CONTROLS OF DVD PLAYER

We suggest you switch the subwoofer on in order to hear more bass sound.

Component: Select appropriate video output option for your connection.

OFF For composite video and S-Video connection.

YUV for component video connection.

RGB fro RGB connection.

T.V. Mode: Select Interlace or Progressive Scan signal output option for your monitor.

Interlace: for common (analog) TV types.

P-Scan: for TV set supported progressive scan signal input. please choose it carefully, most of TV set can't support P-Scan signal, and blank screen will happen.

Quality: Adjust picture quality through sharpness, brightness, contrast option.

First you must stop the unit, then you can go into the video output.

TV Types: To set various colour system signal for the video output.

PAL: The TV broadcast system used in UK, Germany and other countries. It will be output to your TV when you select "PAL"

Multi: Select it if you have a multi system TV set compatible with NTSC and PAL

NTSC: The TV broadcast system used in Korea, Japan, recorded in NTSC colour system. This will be output to your TV when you select "NTSC"

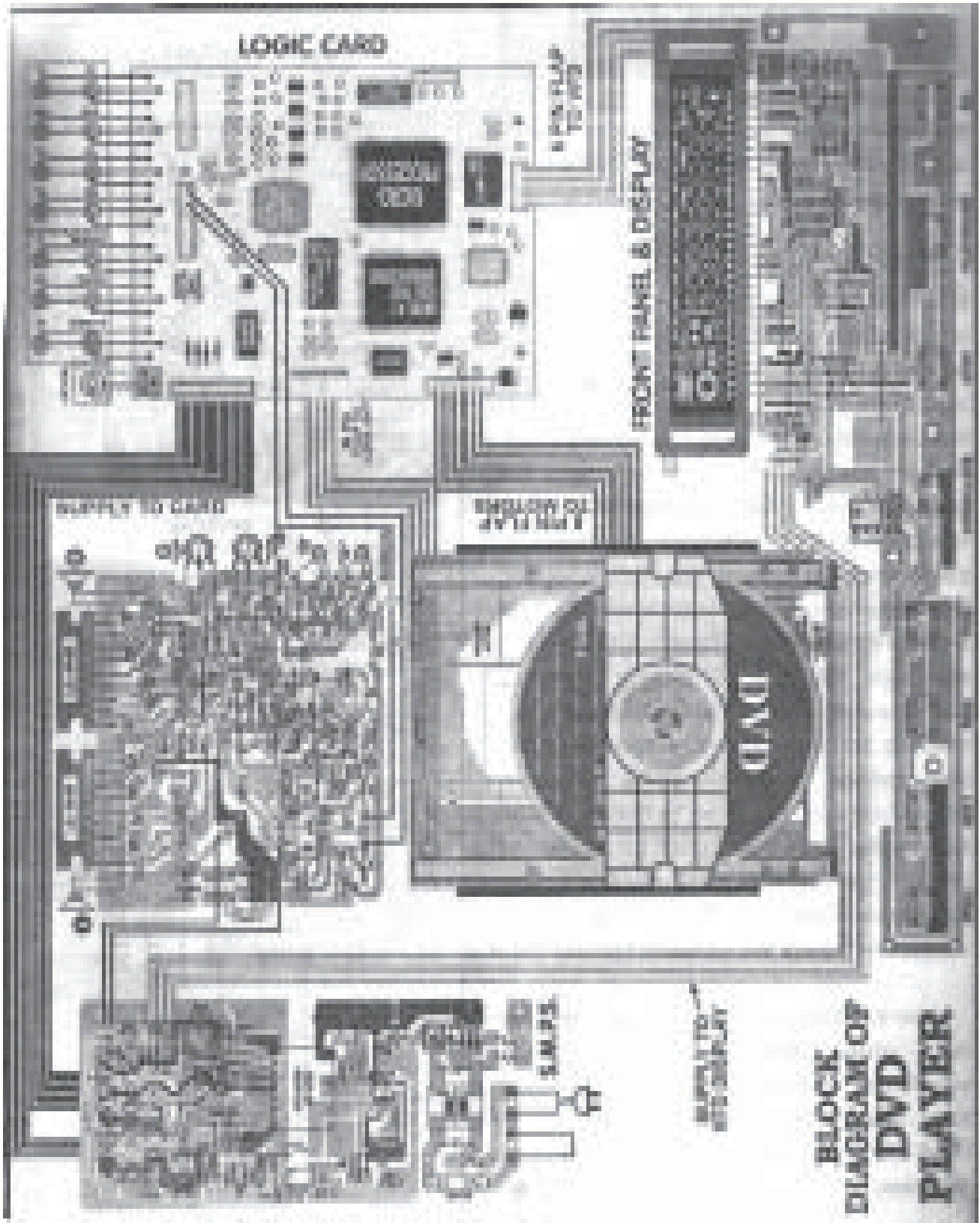

STRUCTURAL DIAGRAM OF DVD PLAYER

DVD Operating Controls:**Following these steps to play a DVD, CD or VCD disc:**

1. Turn on the TV
2. Set the TV to the AV input connection to the player.
3. Turn down the volume on your amplifier and the power it on.
4. SET the amplifier to the AV input connection to the player.
5. Turn on the power button on the back panel of the player, then press standby button on the front panel.
6. Press OPEN / CLOSE on the remote control or front poanel to open the disc tray.
7. Place the disc in the tray with the label side facing up and playback side facing down. If the disc has two sides, place the disc with the desired label facing up.
8. Press OPEN / CLOSE again to close the disc tray.
9. Press PLAY on the remote control or front panel. Many discs will load and begin playing automatically when the disc tray is close. If the DVD has a disc menu, or more than one title, the disc menu may appear.
10. Adjust the volumen of the player by pressing th eVOLUME button on the remote control.

Additional Disc Playback Options:

1. To freeze playback , press PAUSE / STEP.
2. To resume normal play back, press PLAY.
3. To go to the next or previous chapter / track, press NEXT or PREVIOUS.
4. To Scan forward or backward at variable speeds during playback, press F.FWD or F.REW.
5. To play in slow motion at variable speeds, press SLOW button repeatedly.\
6. To stop playback, press STOP once. To resume playback from the same place on the disc, press PLAY.
7. To stop playback completely and restart the disc, press STOP twice. To restart the disc, press PLAY

Using the DVD's Menu:

A DVD is divided into long sections of a picture or a music feature called "titles" When you play a DVD that contains several titles, you can select the title you want using the TITLE button.

When you play DVDs that allow you to select items such as the languages for the subtitles and the languages for the sound, select these items using the MENU button.

1. Press TITLE or MENU button.
2. The disc's menu appears on the TV screen.
3. The content of the menu variables from disc to disc.
4. Press or the number buttons to select the item you want to play or change.
5. Press PLAY button.

Playing VIDEO CDs with PBC functions.

PBC (Playback Control) allows you to play VIDEO CDs interactively by following the menu on the TV Screen.

1. Start playing a VIDEO CD with PBC functions. The menu for your selection appears.
2. Select the item number you want by pressing or the number buttons.
3. Press play button.
4. To return to the menu, press RETURN.
5. Switch PBC functions on and off by pressing PBC functions.

Result:

Operating controls of DVD player and functions are studied.

Question:

Explain the Operating Controls of DVD player ?

19. IDENTIFY THE DIFFERENT STAGES OF REMOTE CONTROL TRANSMETER, RECEIVER

Aim :

Identify the different stages of Remote Control Transmitter, Receiver

Equipment Required :

A remote controller and a colour TV receiver.

Theory :

A remote controller transmitter has got following controller: They are :

Power button: Switch set off temporarily to standby mode. The red light indicator lights up when the set is on standby mode.

To Switch on set from standby mode, press Channel + / = Digit (0-9) or power button.

Personal Zapping buttons:

As personal Zapping buttons, you can surf up to 10 personal channels for each button. For detailed description of functions, refer to section on "Personal Zapping"

Smiley button:

Allows to add and store your personal preference. Channels in your personal preference list. For detailed description of functions, refer to section on "Using your personal Zapping feature".

Smart Sound Button:

Press the Smart sound button repeatedly to access 13 different types of sound settings and choose your desired setting.

Menu Button:

Displays the main menu. Also exits menu from screen.

Cursor Up button:

Allows you to select the next item on the menu.

Cursor Left button:

Allows you to select the sub - menus and adjust the settings.

Volume + / -- button:

Increases or decreases volume.

A/CH(Alternate channel) button:

Allows you to change between the current channel and the previous channel.

Frownie button:

Allows to delete stored personal preference channels in your personal preference list. for detailed description of functions, refer to section on “Personal Zapping”

Smart picture button:

Press the start Picture button repeatedly to access 5 different types of picture settings and choose your desired setting.

Cursor Right button:

Allows you to select the next item on the menu.

Channel + / -- buttons:

Allows you to display the current channel number. It also allows to exit menu from the screen after control adjustment.

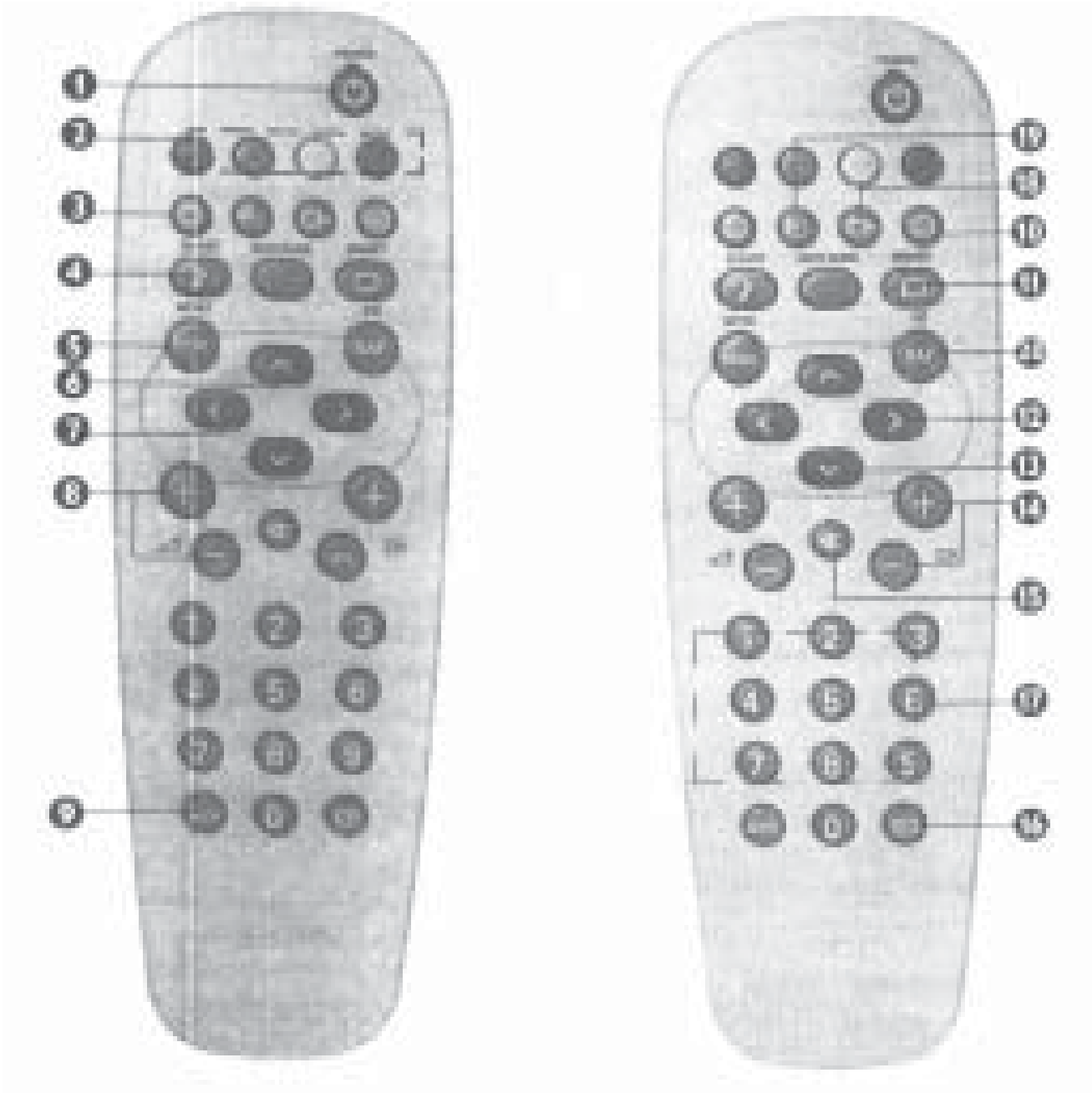

Mute Button:

Mutes sounds. To restore sounds, press button again.

OSD button:

Allows you to display the current channel number. It also allows to exit menu from the screen after control adjustment.

Digit (0-9) buttons:

Press to select a channel. For a 2 -digit channel number, press the first digit and followed immediately by the second digit.

A/B Button: Allows you to select the AV channels.

Sleeptimer button:

Allows you to select a time period after which the set will switch to standby mode automatically.

Operating instructions generally explains the operation of the TV set using the buttons on the remote control unless otherwise stated. Please read the following instructions carefully and follow the steps as shown to familiarise yourself with the installations and all features available in your set.

Result:

Operating controls of T.V. Remote transmitter is studied.

Question:

Explain the operating controls of a TV. Remote transmitter?

20. RECTIFY THE FAULTS IN THE TV REMOTE CONTROL TRANSMITTER, RECEIVER

Aim :

Rectify the faults in the TV Remote Control Transmitter, Receiver

Equipment Required :

A remote controller and a colour TV receiver.

Theory :

A remote controller and PCB of a TV Transmitter operates on a 3 V DC supply. When 3 V DC supply is connected the indicator glows. A remote controller has got 35 press buttons switches. On pressing each button different signals are generated and a same signals are transmitted and received to TV receiver. All these pins also have been used in the key matrix circuit of the remote control hand set. Hence push button can be used in this circuit.

Two layers of copper pins have been made on same side of PCB. Prints related to the IC chip are present on the lower side. The upper sides of all these print have been made insulator by putting enamel paint on them except a small circle like space of each print. Above this insulated layer other prints have been made with golden colour. Each of this prints through a small circle is connected with one the key matrix lines. When a push button of remote set is pressed the conductor material present below the button shorts to golden prints that is it joints two lines of key matrix circuit and LED emits infrared rays.

Push buttons are fixed on PCB in front panel on the hand set of the remote control. In remote set all these buttons are fixed in a rubber sheet. The sheet has projected portions which are flexible and can be pressed down words. Below each projected portion conductor material is present which goes down to short go golden prints.

Maintenance & Instructions

- | | | |
|----|-------------------------|---|
| 1. | Main Power button | Switch mains power on or off. |
| 2. | Standby light indicator | Indicate red light when standby mode is activated. |
| 3. | Remote sensor | Acts as a sensor for activating the controls of the TV when remote control hand set is aimed at it. |
| 4. | Head phone socket | For connection of head phones |
| 5. | Volume - / + buttons | Adjust sound volume softer / louder. |
| 6. | Channel V /A buttons | Select channel in descending / ascending order. |

When two pen torch cells are weaken the remote controller circuit does not operate and infrared rays does not produce proportionally. In this context remove two cells replace new one and operation continues.

When press buttons are disintegrated no proper contact in between circle and press button and hence signals are not generated remote controller does not work. New press buttons are replaced on the same place of the remote controller functions smoothly.

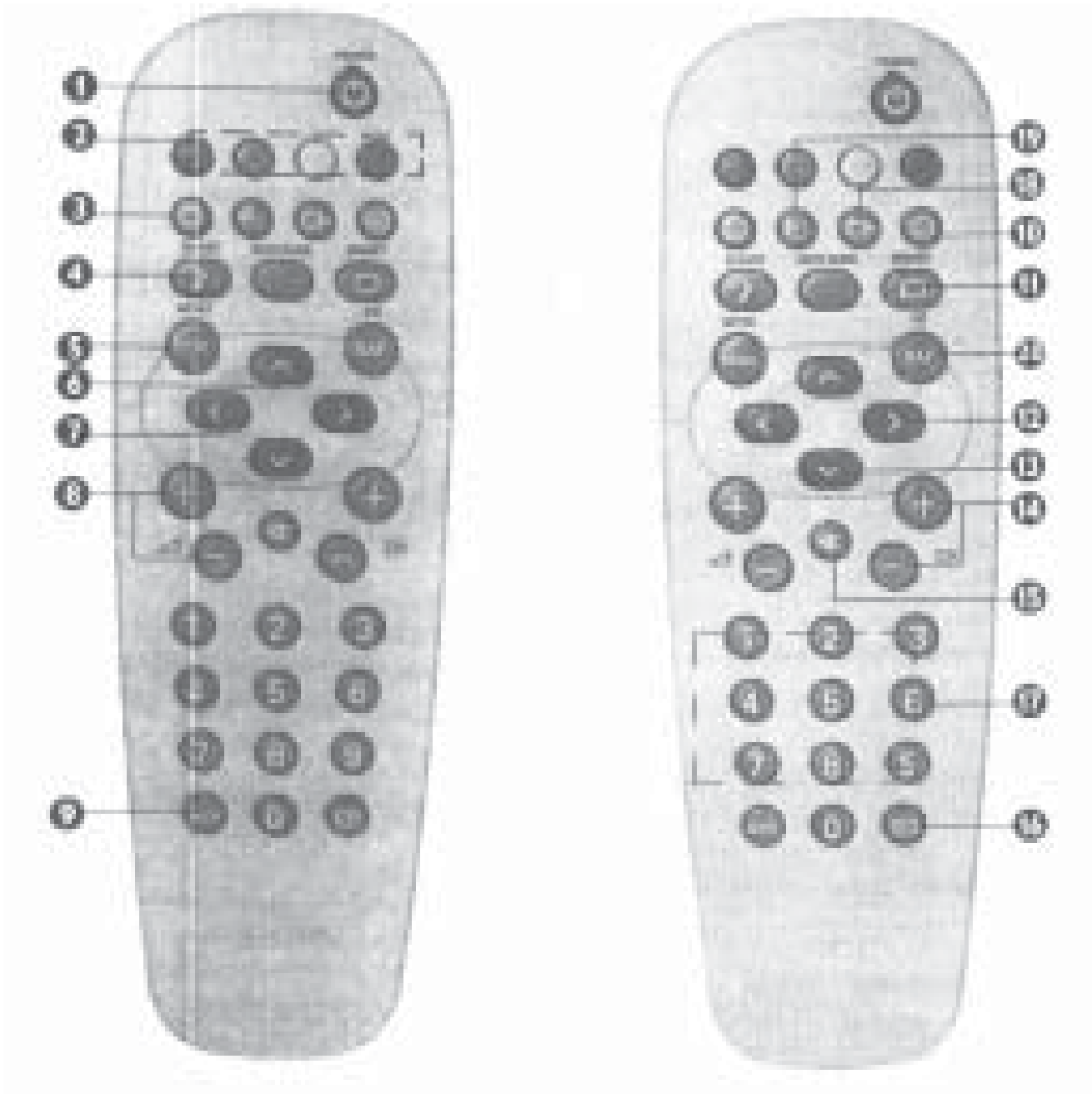
**Result:**

Replacing wecken cells, making proper contact in between press button PCB are the general problems occurs in TV remote controler transmitter.

Question:

Explain the problems and rectification methods in a TV. Remote transmitter?