

## **6. SEMI-CONDUCTOR DEVICES**

### **6.1 Introduction :**

The word 'electronics' is derived from electron mechanics, which means the study of behaviour of an electron under different externally applied fields. Electronics is branch of science and engineering, which deals with electron devices and their utilization. An electronic device is a device in which the conduction takes place by movement of electrons through vacuum, gas or semi-conductor.

The real beginning in electronics was made in 1906, when Lee De forest invented the vacuum triode. In 1948, the invention of the transistor by the three Nobel laureates - John Bardeen, Walter Brattain and William Shockley at Bell Laboratory has completely revolutionized the electronics industry. Transistors opened the floodgate to further developments in Electronics. Result of that, in early sixties, first integrated circuits appeared in the market. Due to rapid developments IC technology, it was happened to fabricate more than 300 000 components on single chip.

An electronic circuit may appear quite complicated and may be capable of performing fantastic functions. But all electronic circuits, however complicated, contain a few basic components such as resistors, capacitors, inductors, tube devices and semi-conductor devices. First three were called passive components and the remaining were active components.

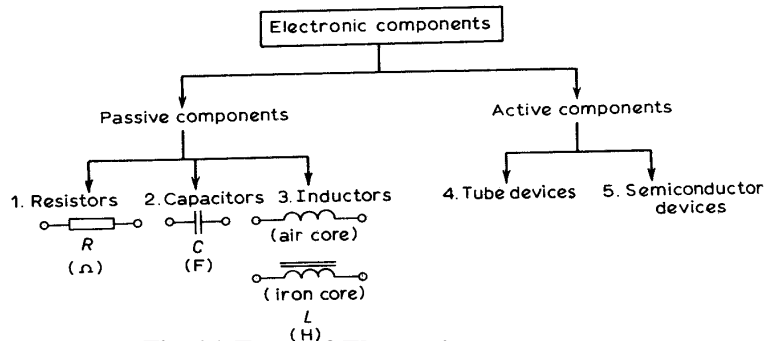

Fig 6.1 Types of Electronic components.

There are many active components used in electronic circuits. But all the active devices or components can be broadly classified into two categories, Tube type and Semiconductor type. Tube devices are prior to the semiconductor devices and they are replacing the tube devices in almost all electronic applications. In this chapter we focus our attention on some semiconductor devices.

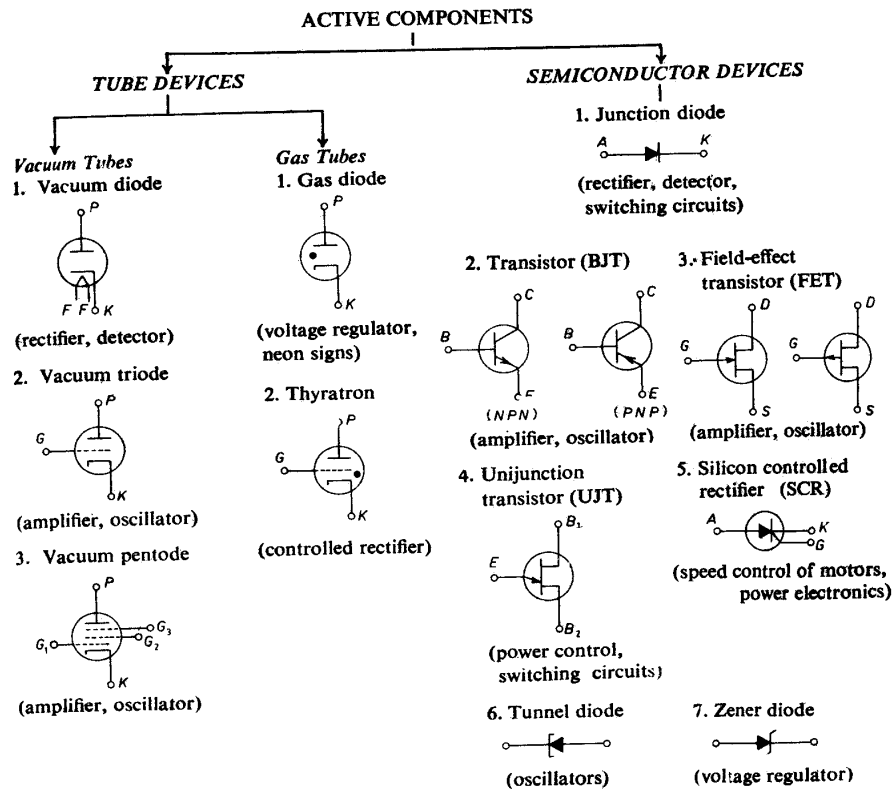

Fig 6.2. Active Components

Certain substances like Germanium, Silicon, Carbon etc., are neither conductors like Copper nor insulators like glass or wood. In other words, the resistivity of these materials lies in between conductors and insulators. Such substances are classified as semi-conductors. The devices or components which are made by semiconducting materials are called semiconductor devices. Semiconductor diode, Transistor, Integrated circuits etc., are best examples for semiconductor devices.

## 6.2. Characteristics of Insulators, Conductors and Semiconductors

All the substances can be electrically classified into three groups, such as conductors, insulators and semiconductors. A conductor is a material in which there are large number of free electrons. It is a good conductor of electricity. It easily allows the passage of electric current through it.e.g., Copper, Alluminum.

Where as insulator is a material which has no free electrons at ordinary temperature. It is a bad conductor of electricity. It does not allows the passage of electric current through it e.g., Glass, Mica.

But semiconductor is a material which has very few electrons at room temperature. Its conducting properties lies between conductors and insulators, hence they were called as semi conductors.e.g., Silicon, Germanium, Corbon.

According to modern theory, matter is electrical in nature. All the materials are composed of very small particles called atoms. An atom consists of neutrons, protons and electrons. The central part of atoms is called neucleous and acomidates neutrons and protons. The electrons revolve around fixed orbits around the neucleous.

The electrons in the outer most orbit of an atom are known as valence electrons. The number of valency electrons will determine the nature (i.e., conductor, insulator or semi-conductor) of a material. The valence electrons are loosely attached to the nucleus. Hence they also called free electrons.

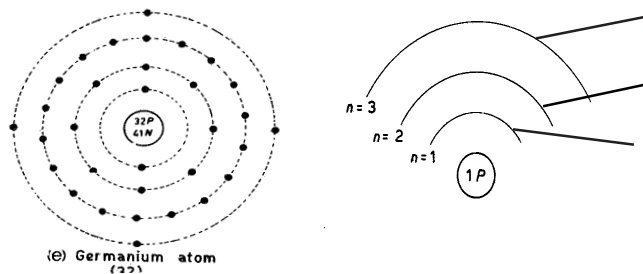

Fig 6.3 Atomic structure

### 6.2.1 Characteristics of Conductors

1. Conductors or conducting materials has plenty of free electrons. Hence they easily allows the passage of electric current through them.
2. The atoms of conducting material has less than FOUR valency electrons (i.e. 1 to 3), e.g., Silver, Copper, Alluminium. etc.,
3. The valence band and conduction band are overlapped each other.
4. The resistivity of conductors will increase with rise in temperature

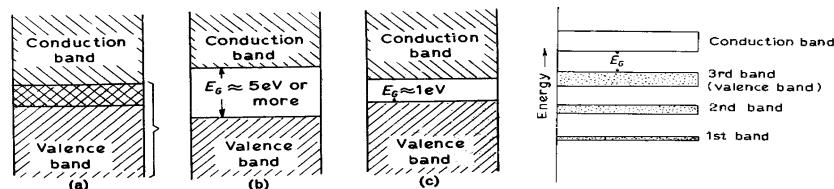

Fig 6.4. Energy band diagram of a) Conductors b) Insulators c) Semiconductors

### 6.2.2. Characteristics of Insulators

1. In insulators or insulating materials, the valency electrons are tightly bound to their parent atoms. There is no free charge carriers. Hence they does not allows the passage of electric current through them.
2. The number of valency electrons are more than four.
3. They have very wide energy gap between valency and conduction band (about 5 ev or more)
4. Insulators loses their properties and become conductors at very high temperatures
5. They have negative temperatures coefficient of resistance.
6. The resistance varies between 16 to 19 ohms.
7. Examples for insulators - Glass, PVC, Mica.

### 6.2.3. Characteristics of Semiconductors

1. Materials whose properties lies between conductors and insulators are called semi-conductors. These are neither conductor nor insulators.
2. The number of valency electrons are *four*.
3. The energy gap is very narrow (i.e., 1 ev.)
4. The resistivity of semiconductor is less than insulator and more than conductor.

5. Semi-conductors have negative temperature co-efficient of resistance.
6. When a suitable metallic impurity is added to a semi conductor its current conducting properties change appreciably.
7. Example. Silicon, Germanium, Carbon.

### 6.3 Types of Semiconductors

Semi conductors can be classified as below

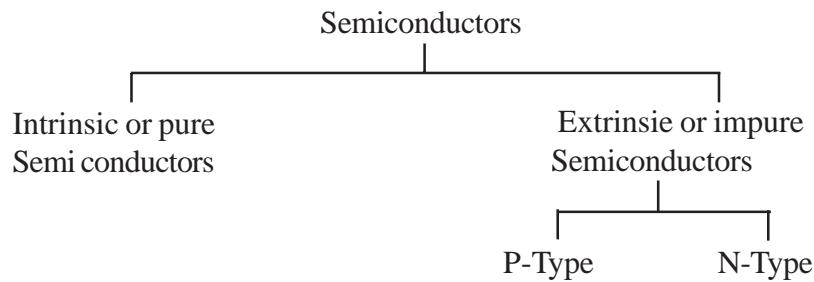

**Intrinsic semiconductor :** Semiconductor, extremely in pure form is called intrinsic semiconductor.

e.g., Pure Germanium and Pure Silicon.

In this, the number of conduction electrons is equal to number of holes. At room temperature hole electron pairs are created. When electric field is applied across an intrinsic semiconductor, the current conduction takes place by two processes, namely by free electrons and holes. The total current inside the semiconductor is the sum of currents due to free electrons and holes.

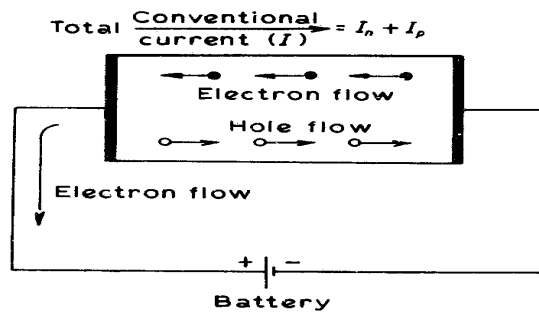

Fig 6.5. Conduction of Current in an intrinsic semiconductor

**Extrinsic semiconductor :**

When pure semiconductors added with some suitable impurity or doping agent or dopant at 1 part in  $10^8$  then it is called extrinsic semiconductor.

The usual doping agents are

- 1) Pentavalent atoms having *five* valence electrons (Arsenic, Antimony, Phosphorus)
- 2) Trivalent atoms having *three* valence electrons (Gallium, Indium, Aluminium)

Pentavalent atom is known as donor atom and the Trivalent atom is called acceptor. Depending on the type doping material (impurity) used, the extrinsic semiconductors can be sub- divided into two classes.

**1. N-Type semiconductor**

When pentavalent material like Antimony, phosphorus is added to pure Germanium crystal (or pure intrinsic semiconductor) N-type semiconductor is formed. The material added as impurity is called donor. The formation of N type material leads an excess of electrons in its atomic structure. Hence it is called N-type material.

**2. P-Type semiconductors**

When a trivalent material (like Boron, lithium) is added to pure semi-conductor, P-Type semiconductor is formed. The material added as impurity is called acceptor. The formation of P- type material leads a deficit of electrons and the material acquire positive charge. Hence it is called P-Type material.

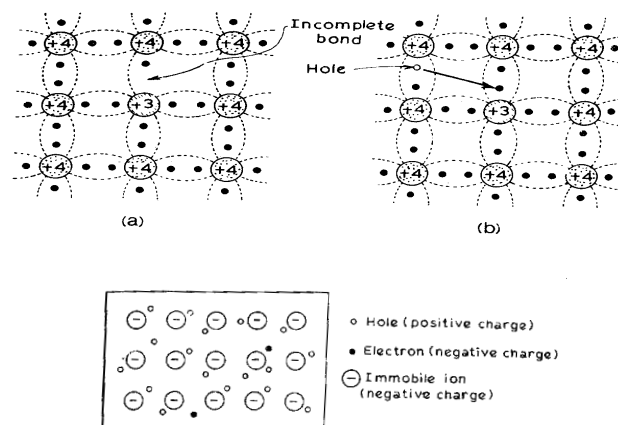

**Fig 6.6 Structure of P-Type Semi conductor**

### 6.4. Comparison between P-Type and N-Type semiconductor

P-Type semiconductor	N-Type semiconductor
1. When Trivalent impurity like Boron, lithium is added to pure Semiconductor, P-Type material is formed.	1. When pentavalent impurity like Phosphorus, Antimony is added to pure semiconductor, N-Type material is formed.
2. The impurity added is known as acceptor.	2. The impurity added is called as donor.
3. There is a deficiency in electrons, hence an excess of holes.	3. There is an excess of electrons.
4. The conduction of charge is due to holes.	4. The conduction of charge is due to electrons.
5. The majority carriers are holes and minority carriers are electrons.	5. The majority carriers are electrons and minority carriers are holes.
6. Fermi level shifts towards valance band.	6. Fermi level shifts towards conduction band.

### 6.5. P - N Junction

When P-Type and N-Type semiconductors are fabricated on a single crystal by special techniques, a new semiconductor is formed. It is known as P-N junction or semi conductor diode. The most important characteristic of a P-N junction is its ability to conduct current in one direction only. In other words, it offers low resistance in one direction and very high resistance in other direction almost as insulator. Diodes are used in rectifiers.

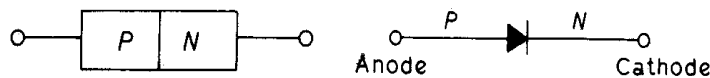

Fig 6.7 (a) P - N junction symbol.

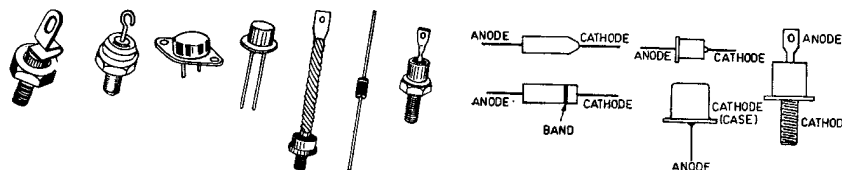

Fig 6.8 (b) Actual Shapes of P-N junction diode.

### 6.5.2. Working of P-N junction with forward bias.

When P N junction is connected to a battery such that the P-side is connected to positive terminal and N-side to negative terminal of the battery (as shown in fig) such type biasing of P N junction is called forward biasing.

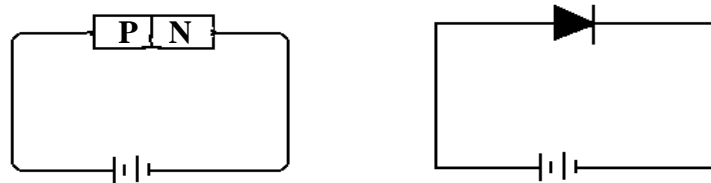

Fig 6.9 P N Junction with forward bias

When the P N junction is forward biased, the holes are repelled by the positive terminal of the battery and electrons repelled by negative terminal of the battery. They are compelled to move towards the junction. This reduces the potential barrier and majority carriers diffuse across the junction to recombine. This causes a free path for flow of electric current through the junction and the diode starts conducting.

### 6.5.3. Working of P N junction with Reverse bias

When a P N junction is connected with a battery such that, the P-side is connected to negative terminal and N-side to positive terminal of the battery (as shown in fig) such type of biasing of P N junction is called as P N junction with reverse biasing.

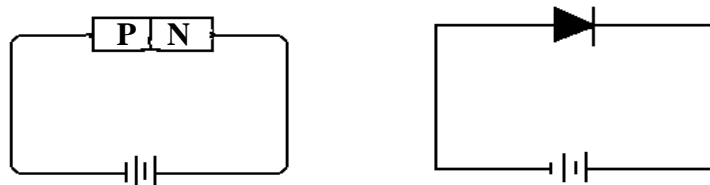

Fig 6.10 P N junction with Reverse bias.

When the P N junction is reverse biased. The holes are attracted by the negative terminal of the battery and electrons are attracted by the positive terminal of the battery. Thus the majority carriers are drawn away from the junction.

This action widens the depletion region and increases the barrier potential and reduces the possibility of any conduction of electric current through the junction, hence the diode does not conduct on reverse bias.

#### 6.5.4. V - I characteristics of a PN-junction diode

The graph between the voltage applied across the terminals of a PN junction and resultant current passing through it, is called VI characteristic curve of PN junction diode. When the diode is forward biased and applied voltage is increased from zero, very small current will flow till the external voltage overcomes the barrier potential. After that, current through diode increases rapidly with the increase in applied voltage. These characteristics are called forward characteristics and the graph is known as forward characteristic curve.

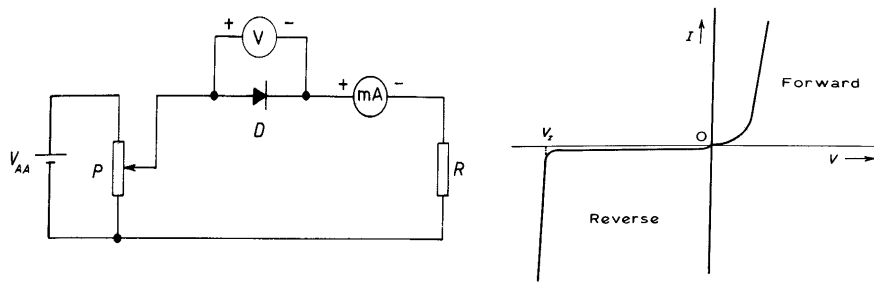

Fig 6.11. V I characteristics of PN junction diode.

When the diode is reverse biased and applied voltage is increased from zero, a very small current (in order of nano amps or micro amps) will flow due to minority carriers. Further increase in voltage to certain value called breakdown voltage the leakage or reverse current increases sharply. Any further increase in voltage causes burnout of diode. These characteristics are known as reverse characteristics and the graph is called reverse characteristic curve.

### 6.6 Zener Diode

In many electronic applications, it is desired that the output should remain constant regardless of the variations in the input voltage or load. In order to ensure this, a voltage stabilizing device, called voltage stabilizer is used. Zener Diode is one of the voltage stabilizer.

*A properly doped crystal diode which has a sharp breakdown voltage is known as Zener Diode.*

The following points may be noted about the Zener diode :

- (i) A Zener diode is like an ordinary diode and that it is properly doped to have a sharp breakdown voltage.
- (ii) A Zener diode is always reverse connected i.e. it is always reverse biased.
- (iii) A Zener diode has sharp breakdown voltage called Zener voltage,  $V_Z$ .
- (iv) When forward biased, its characteristics are just that of ordinary diode.
- (v) The Zener diode is not immediately burnt just because it has entered the breakdown region.

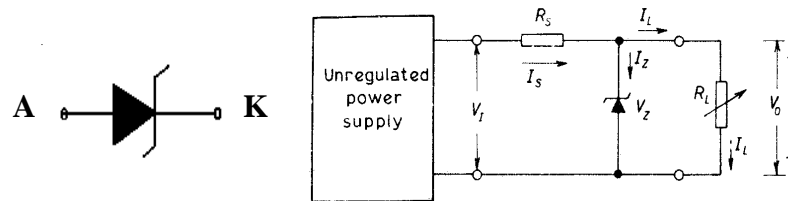

**Fig 6.12 Zener Diode and its use**

(vi) Zener diode is a Silicon P-N Junction diode. Its breakdown voltage is kept lower than that of an ordinary diode and each diode is designed to have a specific breakdown voltage.

### VI Characteristics of Zener Diode

The typical VI Characteristics of a zener diode are as shown in graph. The forward characteristics are similar to ordinary diode. But its reverse characteristics are different.

When it is reverse biased, the amount of leakage current increases suddenly by increasing the reverse bias. The current flowing through the zener diode on breakdown voltage is called avalanche current or Zener current.

### Applications

A Zener diode is used in voltage regulator circuits, biasing and comparison circuits, meter protection, motor protection (used in electronic equipments) calibration of voltmeters, etc.,

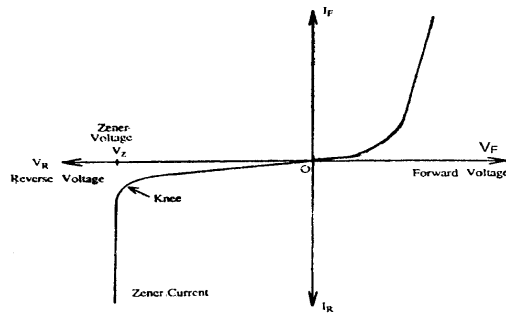

Fig 6.13 VI Characteristics of Zener Diode

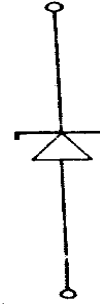

Fig 6.14 Tunnel Diode Symbol

### 6.7 Tunnel diode

A tunnel diode is basically a heavily doped PN junction. The width of depletion layer is about  $100 \text{ \AA}$ . Due to the extremely thin depletion layer, electrons are capable of tunneling through one side of the junction to the other at very low forward bias voltage (0 to 5V). Generally, the tunnel diodes are made from Gallium Arsenide (GaAs). Its operation is similar to that of ordinary PN junction diode.

**Applications:** It is used in Amplifiers, oscillators, switching devices, high frequency oscillators etc.,

### 6.8 L.E.D ( Light Emitting Diode) :

It is a special type of diode which is different from a conventional semiconductor diode. It is made from gallium-arsenide (GaAs) or gallium phosphide (GaP) PN-junction instead of a germanium or silicon. The device is used as a light indicator in electronic equipments.

In a conventional diode, the heat developed during 'recombination' of holes and free-electrons is absorbed by the semiconducting materials. But in LED, energy is released by the PN-junction in the form of light rays of visible and Infra-red when it was forward biased. They works with low voltage (1 to 3V) and takes 10 to 15mA current and available in 4 different colours Green, Red, Yellow and Blue. The process in which light energy is obtained by applying electrical energy is called *electro-luminescence*.

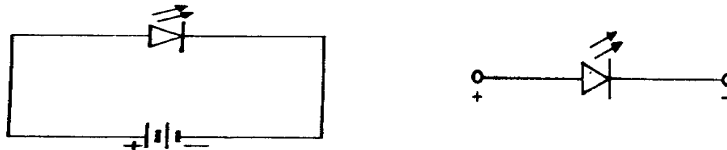

Fig 6.15 Light Emitting Diode

## 6.9 LCD (Liquid Crystal Displays)

The LCD consists of an orderly arranged Liquid Crystal Cells. A liquid crystal is an organic material which flows like a liquid at room temperature. A Liquid Crystal cell consists of a thin layer of Liquid Crystal, sandwiched between two electrodes. One is transparent glass and the other is reflective type glass.

When the Liquid Crystal Cell is energised (applied with some voltage) the molecules of the liquid are disturbed and they absorb the incident light and give a localized black display.

**Application :** It is used in watches, portable electronic instruments digital displays, video monitors.

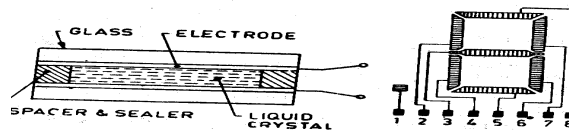
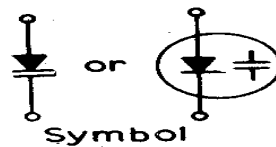

Fig 6.16 Liquid Crystal Display (a) Basic Construction (b) Practical use

## 6.10 Varactor diode

A varactor Diode is nothing but a junction diode under reverse bias. The width of the depletion layer depends on the amount of the reverse bias applied. In this depletion layer acts as insulator and P region, N region are like plates of the capacitor. The capacitance of this diode capacitor is known as transition capacitance ( $C_T$ ).



**Applications:** It is used in T.V. receivers, Radio receivers, Communication equipments.

## 6.11 Solar cells

A solar cell or solar battery is basically a heavily doped PN junction diode. It converts solar energy into electrical energy. It is made from Germanium, Silicon, Ga As, In As or Cd As. The PN junction is packed in

a box, with a glass window on top, so that, light may fall on P and N type materials. The thickness of P and N regions are kept very small. A nickel plated ring is arranged on plate and acts as positive output terminal and a metal contact is arranged at the bottom, to act on negative output terminal

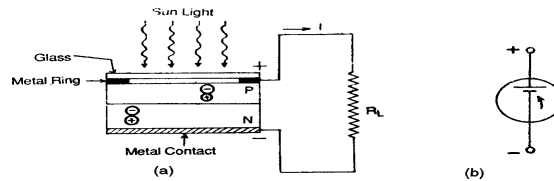

**Fig 6.17 Solar cell (a) Basic consists (b) Symbol**

When light falls on the PN junction, the valence electrons are activated and forms electrons-hole pairs. The majority carriers are obstructed by depletion layer, but the minority carriers slide down the barrier and constitutes current. Accumulation of electrons and holes on two sides of junction will produce circuit voltage about 0.6V. The current or the voltage developed is depends on the level of illumination and the surface exposed to light. A number of such diodes/cells are connected in series and parallel and the energy so obtained is connected to a rechargeable battery. An orderly connected group of solar cells is called P.V. array.

**Application :** Solar cells are Non conventional energy sources. They are used in satellites, space vehicles, solar lamps, solar water heater, solar pumpsets etc.,

## 6.12 Photo Diode

A photo diode is a reverse biased PN junction diode, which is designed to respond to photon absorption. When light is allowed to fall on the reverse biased photo diode, a large change in minority carrier concentration and causes increase in reverse current. The current through the diode is directly proportional to the light flux falling on the junction.

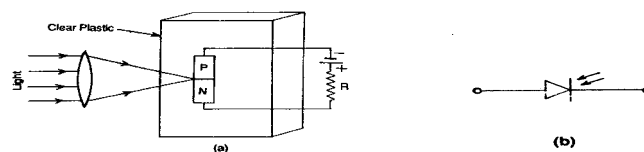

**Fig 6.18 Photo diode (a) Basic Construction (b) Symbol**

It is used in light detection, switches, reading of computer punched cords, optical communication systems it instrumentation and control.

### 6.13 Transistor

Transistor was invented by John Bardeen and others in 1948 at Bell Laboratory, America. Transistors have several advantages over vacuum tubes. A Transistor is basically Silicon or Germanium crystal containing three separate regions. A transistor transfers a signal from a low resistance circuit to high resistance circuit.

There are two types of transistors., namely N P N and P N P transistor the middle region of transistor is called base and the two outer regions are called emitter and collector.

**Base (B) :** It is very lightly doped and is thin in size. The function of base is to pass the majority carriers (i.e., electrons in N P N transistor or holes in P N P transistor) to collector.

**Emitter (E) :** It is heavily doped than the other two regions and little larger than base. The main function of emitter is to emit or inject the electrons or holes into base.

**Collector (C) :** The doping level of collector is in between the doping of emitter and base. The function of collector is to collect the charge (electrons or holes ) from the base.

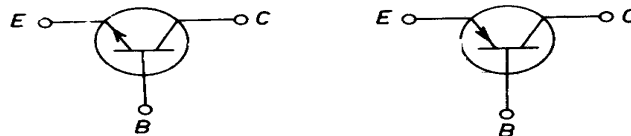

NPN Transistor

PNP Transistor

### 6.14 Transistor configurations or transistor connections.

A transistor can be connected in a circuit in the following three ways.

- i) Common Base configuration
- ii) Common Emitter configuration
- ii) Common Collector configuration

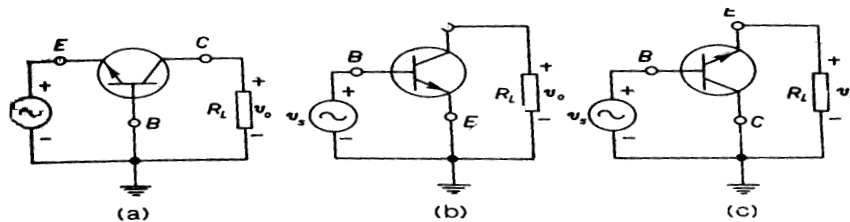
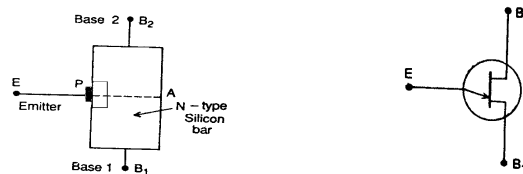

Fig 6.19 Configuration of transistor (N P N Type)

The three terminals of transistor can be connected in such a way that, one terminal is common to both input and output terminals. Each circuit connection has specific advantages and disadvantages. But regardless of circuit connections, The emitter (or emitter- base junction) is always forward biased, while the collector (or collector - base junction ) is reverse biased.

### 6.15 UJT (Uni Junction Transistor)

It consists of a single P-N junction and made with silicon. Its N-region is kept large than P-region. Two leads are connected to the N-regions as shown figure.



**Fig. 6.20 UJT (Uni Junction Transistor)**

The two terminals are called base-1 and base-2, one terminal is taken P-region is called Emitter. In common type circuit, base-1 is grounded and the positive signal is applied to base-2. The N-region acts as a voltage divider.

If the magnitude of emitter voltage is lesser than the voltage present on the base, the transistors will remain in reverse bias state. When the emitter voltage exceed the voltage present on the base, the transistor will be changed into forward bias state and the holes will start to reach the base-1 region by crossing the emitter junction.

In this way, the conduction of emitter current will start and the effective resistance of the junction will be reduced. It will produce a rise in the emitter voltage.

**Applications:** UJT are used low frequency, oscillators and timer circuits

### 6.16 Field Effect Transistor

FET or JFET (Junction Field Effect Transistor) is a three terminal unipolar, solid-state device. In this transistor, the current is controlled by an electric field as in vacuum tubes.

A FET can be fabricated with either N-channel or P-channel. But, N-channel is preferred. For fabricating N-channel FET, a narrow bar of N-type semiconductors is taken and two P-type junction are diffused on opposite sides of its middle part.

These two junctions form two P-N diodes or gates and the area between the two gates is called the channel. The two gates are connected internally and a connecting lead is brought out of the device which is called the gate terminal. Two leads are joined to the bar, are on each side and they are called the source and drain.

P-channel FET is similar in construction except that it uses P-type bar and two N-type junctions.

- (i) **Source** : The terminal through which majority carriers enter the channel.
- (ii) **Drain** : The terminal through which majority carriers leave the channel.
- (iii) **Gate** : The terminal formed by joining internally the two impurities regions. It controls the travelling of majority carries from source to Drain.

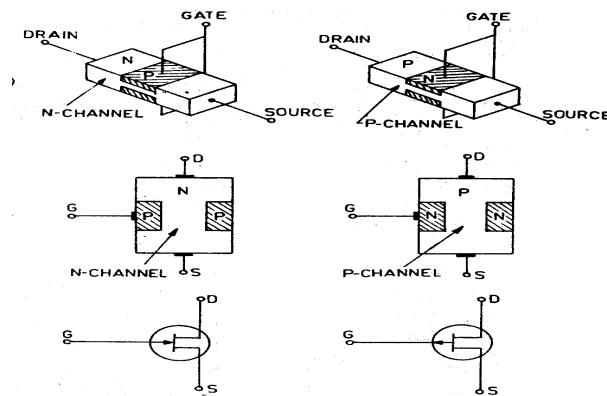

**Fig 6.21 Construction and symbols of FET**

In this type of transistor, the current is composed of only one type of charge carriers i.e., (major carriers) (electrons in case of N-channel and holes in case of P-channel). Hence the device is called a unipolar Device.

**Advantages :**

- (1) High input impedance
- (2) small size, rugged and long life
- (3) Low noise, good high frequency response.
- (4) better thermal stability
- (5) High power gain.

**Applications** It is used in

- (1) electronic testing instruments.
- (2) In logic circuits.
- (3) As “mixer” of FM in TV receivers.
- (4) As VVR ( voltage - variable-resistor) in operational amplifiers and tone control circuits of audio amplifiers.
- (5) In computers for large scale integration (LSI), in memory circuits.

### 6.17 SCR ( Silicon controlled Rectifier)

A silicon controlled Rectifiers or SCR is a four layer, three terminal semiconductor device. It is also called as Thyristor. The maximum current rating of SCR is 8000A.

#### Construction

The semiconducting material Silicon is used for construction of SCR. Hence it is called as Silicon Controlled Rectifier. Three terminals are called *Anode*, *Cathode* and *Gate*. If we split the SCR into two separate parts as shown in the fig., then we have a PNP transistor( $T_1$ ) and a NPN transistor( $T_2$ ).

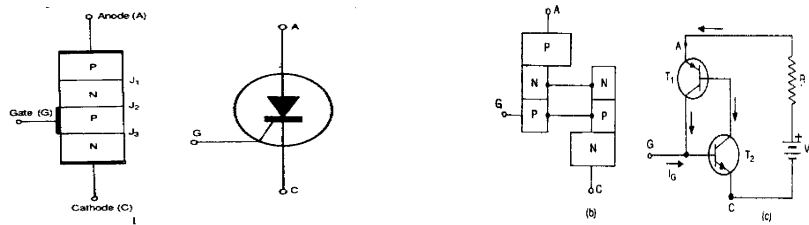

Fig 6.22 Silicon Controlled Rectifier

#### Working

The device acts in such a way that no current conducts through it till a definite positive voltage is applied at the gate even if the normal positive and negative voltage are being present on the anode and the cathode respectively. Similarly, in the reverse bias state also the conduction of current does not start below the breakdown or avalanche voltage being present across the device.

If a SCR starts to function on 18 volts and the voltage present across it is 17 volts ( i.e., one volt less than the required value) the SCR will not conduct. When a signal of 1.5 V , 30 mA is applied to the gate, the SCR will start to conduct and it will continue to conduct till it is not switch ‘off’ completely at least for 20 micro seconds.

### Applications

A SCR can conduct 30 to 100 amperes of current. It is used in switching circuits, Regulated power supplies, Inverters, Radar modulators servo system and electronic ignition system etc. It cannot be used for amplification purpose.

### 6.18 Comparison between the properties of Silicon and Germanium

Silicon and Germanium are important semiconducting materials. Most of electronic components (active components) like diode, transistor, integrated circuits etc., are made from Silicon and Germanium. The following discussion provides a comprehensive and comparative study of properties of Silicon and Germanium.

1. The mobility of electrons in Silicon is greater than Germanium.
2. The concentration of atoms in Ge and Si are  $5 \times 10^{22}$  and  $4.4 \times 10^{22}$  atoms/cm<sup>2</sup> respectively.
3. The conductivity is also greater in silicon than germanium.
4. The value of energy gap  $E_G$  i.e., forbidden energy gap is 0.72eV where as for silicon is 1.1eV.
5. Silicon has comparatively high resistivity.
6. Silicon is more capable to work at higher temperatures in comparison to germanium, because silicon has more capability of thermal radiation.
7. The availability of Silicon is more than Germanium.

### Questions for evaluation:

1. Define conductors, semiconductors and insulators.
2. Define valency electrons, valency band.
3. What are the characteristics of conductors?
4. What are the characteristics of semiconductors?
5. What are the characteristics of insulators?
6. Classify the semiconductors.
7. Write the comparison between P-type and N-type semiconductors.
8. Define PN junction. Explain its working when it was
  - a) Forward Bias
  - c) Reverse Bias.
9. Explain the VI characteristics of PN junction diode.
10. Name the basic types of transistors and draw their symbols.
11. Draw the circuit diagrams for CB, CE, CC configurations.

# 7. POWER SUPPLIES

## 7.1 Introduction

A power supply is a unit which is designed to operate at the available source of supply such as A.C. mains or 3-phase A.C or D.C. etc., and feeds an equipment as per requirements of the same. This unit may be a part of the equipment or may be made as a separate unit.

The main types of power supplies are given below.

1. A.C mains power supply
2. Voltage stabilizer type power supply
3. Voltage regulator type power supply.
4. Converter type power supply.(AC to DC)
5. Inverter type power supply.(DC to AC)
6. S.M.P.S. ( Switch mode power supply)
7. U.P.S ( Uninterruptable power supply).

In this, we focus our attention on converter type power supplies. Basically, the converter type power supply is a rectifier. It consists of a step down transformer, a rectifier, a filter and a voltage regulator.

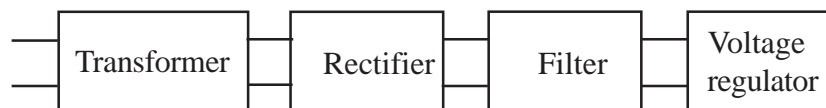

**Fig 7.1 Block diagram of Power Supply unit**

## 7.2 Rectifiers

Now a days A.C. is employed as a source of electricity all over the world because of its easy and economical production and distribution.

Through A.C. is suitable for most of the electrical applications but there are some other applications of electricity for which D.C is essential e.g., (1) Electroplating (2) Electro-typing (3) Arc lamp (4) Battery charging etc. All the electronic equipments run with DC supply only. Hence it becomes necessary to convert A.C into D.C

The conversion of A.C. into D.C. is called rectification. The unit employed for rectification is called rectifier. *The process of conversion of A.C into D.C. is known as rectification.*

### Rectifiers are following types:

1. Diode valve rectifiers
2. Metal rectifiers
  - (i) Selenium rectifiers
  - (ii) Copper oxide rectifiers
3. Solid state rectifiers

Again the rectifier circuits may be classified into following three main classes.

- (1) Half - wave rectifier
- (2) Full - wave rectifier
- (3) Bridge rectifier.

All the above three types of circuits can be made by employing valve, metal or solid state rectifiers.

## 7.3 Half - Wave Rectifier (By using Semiconductor Diode)

A Rectifier circuit designed with a single - diode which provides an output, only for half - cycle of A.C. (only for positive half - cycle) is called a half - wave rectifier.

In half-wave rectifier the rectifier conducts currents during the positive half-Cycles of input A.C. supply only. The negative half - cycle of a.c. supply are suppressed. During negative half-cycles, diode is reverse biased and no current is conducted and hence no voltage appears across the load

Therefore current always flows in one direction (i.e d.c) through the load. But the efficiency of a half-wave rectifier is poor and a multistage filter circuit is required for the conversion of pulsating D.C into smooth DC

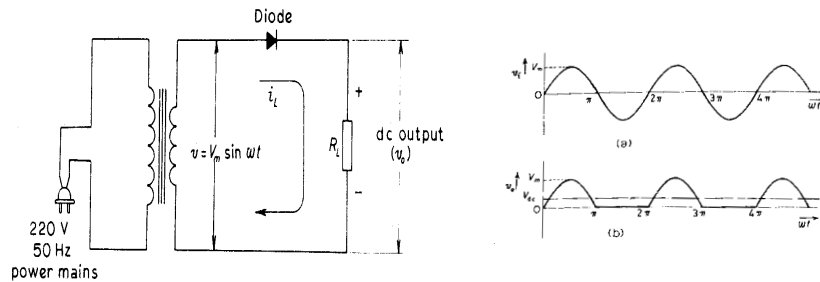

Fig 7.2 Half Wave Rectifier

## 7.4 Full-wave Rectifier

In full-wave rectification, current flows through the load in the same direction for both half-cycles of input a.c. voltage. This can be achieved with two diodes working alternately. For the positive half-cycle of input voltage, one diode supplies current to the load and for the negative half-cycle, the other diode does so. Current being always in the same direction through the load.

Therefore, a full-wave rectifier utilizes both half-cycles of input a.c. voltage to produce the d.c. output.

### 7.4.1 Full wave Rectifier by using Centre tapped Transformer

The basic circuit arrangement is as shown in figure. It consists of a Centre tapped transformer, two diodes.

The load is connected as shown in fig. During the positive half-cycle, the anode of the diode  $D_1$  becomes positive and the flow of electrons takes place through the diode  $D_1$  (cathode to anode), secondary windings upper section and the load resistor  $R_L$  the diode  $D_2$  remains inactive during this period.

During negative half-cycle the diode  $D_1$  remains inactive but the flow of electrons takes place through the diode  $D_2$  due to positive potential of the lower terminals of the secondary winding.

In this way, output is obtained for each half-cycle because of alternate functions of the two diodes.

The ripple frequency of the circuit is double of the supply frequency (normally 100 Hz).

The circuit has a higher efficiency and due to flow of currents opposite directions through the two sections of the secondary winding

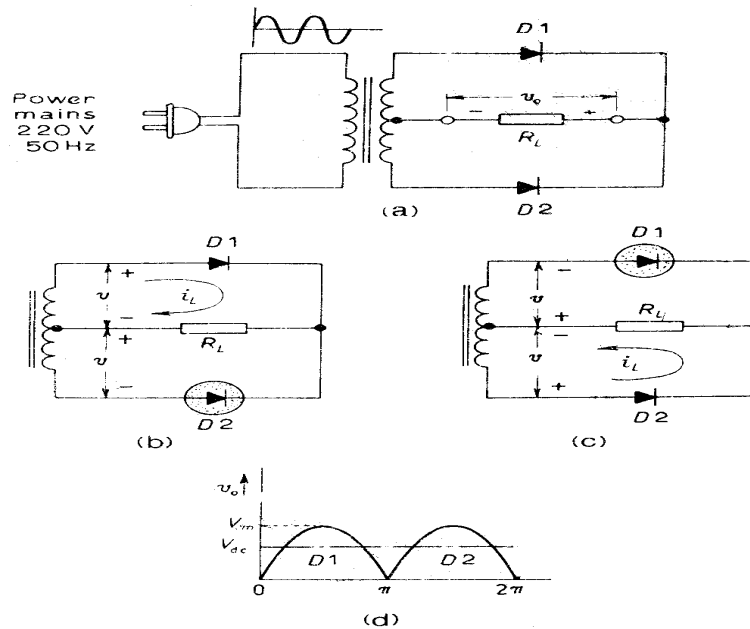

Fig 7.3 Full Wave Rectifier by using centre tap transformer

#### Disadvantages :

- (i) It is difficult to locate the center-tap on the secondary winding.
- (ii) The d.c. output is small.
- (iii) The diodes used must have high peak inverse voltage.

#### 7.4.2 Full-wave bridge rectifier

As the name indicates, it is a full wave rectifier. It consists of four diodes and connected like *wheat stone bridge circuit*, hence the circuit is known as bridge circuit, hence the circuit is known as bridge rectifier. It contains four diodes  $D_1$ ,  $D_2$ ,  $D_3$  and  $D_4$  connected to form bridge as shown in circuit diagram

The a.c. supply to be rectified is applied to the diagonally opposite ends of the bridge through the transformer. Between other two ends of the bridge the load resistance  $R_L$  is connected

**Operation :** During the positive half-cycle of secondary voltage, the end P of the secondary winding becomes positive and the end Q negative, this makes diodes  $D_1$  and  $D_4$  forward biased while diodes  $D_2$  and  $D_3$  are reverse biased. therefore, only diodes  $D_1$  and  $D_4$  conduct. Hence current flows from A to B through the load  $R_L$ .

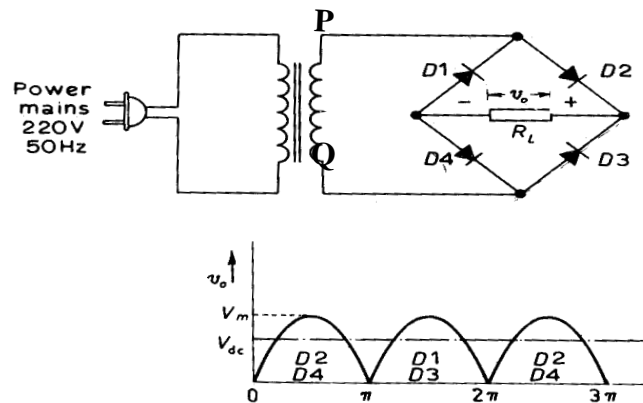

Fig 7.4 Bridge Rectifier

During the negative half-cycle of secondary voltage end P becomes negative and end Q positive, this makes diodes,  $D_2$  and  $D_3$  forward biased where as diodes  $D_1$  and  $D_4$  are reverse biased, therefore, only  $D_2$  and  $D_3$  conduct. The current flows from A to B through the load i.e. in the same direction as for the same positive half-cycle therefore, d.c. output is detained across load  $R_L$ .

#### Advantages of full-wave bridge rectifier

- (i) The need for centre tapped transformer is eliminated.
- (ii) The output is twice that of the centre -tap circuit for the same secondary voltage.
- (iii) The peak-inverse voltage is one-half that of the centre-tap circuit.

#### Dis-Advantages :

- (i) It requires four diodes.
- (ii) Internal voltage drop is more.

#### 7.5 Metal rectifiers

The metal rectifiers are of following two types.

- (1) Selenium rectifier
- (2) Copper oxide rectifier.

A number of selenium or copper oxide rectifiers may be connected in series for the rectification of high voltages as required.

**(a) Selenium rectifier :**

It consists of two metallic plates made of iron or Aluminium, A layer of 0.05mm thick of selenium is coated by heat treatment on one side of a plate. A counter electrode is made on the selenium layer by spraying an alloy metal having low melting point.

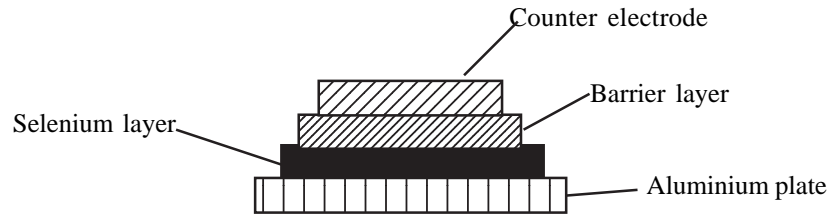
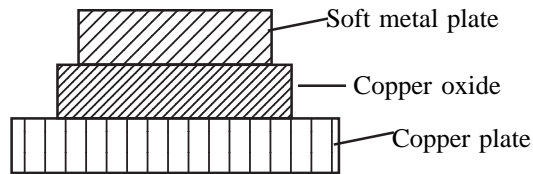

**Fig 7.5 Selenium Rectifier**

A barrier layer is also formed by chemical action between the selenium and counter electrode layers.

The metallic plate acts as anode and counter electrode as cathode, the rectifier operates at 6 volts but it can withstand an inverse voltage of 18 volts. Its current density is 35 to 40 mA / cm<sup>2</sup> and its efficiency is 50 to 75 percent.

**(b) Copper-oxide rectifier :** It consists of a copper plate which is coated with a layer of copper-oxide.



**Fig 7.6 Copper Oxide Rectifier.**

The copper plate is allowed to cool down slowly in the air after heating it upto 1000°C temperature; Red hot copper combines with the oxygen present in the air and prepares a copper-oxide layer on it self. On side layer is cleaned off by chemical action and a counter electrode is made on the other side layer. The counter electrode is made with an alloy metal having low melting point. The copper plate acts as anode and the alloy metal electrode as cathode. The current density of the rectifier is 0.1 to 0.5 A/mm<sup>2</sup>.

This rectifier can be operated at 6 volts and its efficiency is 70% to 80%.

### 7.6 The need for filter

The output of a rectifier contains a.c. ripple too in addition to the d.c. in order to obtain pure D.C., a.c. ripples should necessarily be removed.

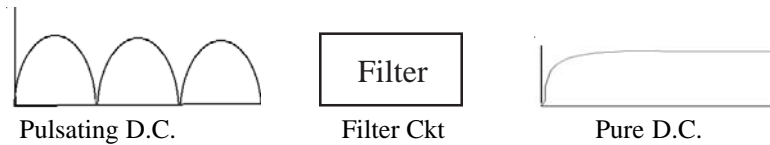

Fig 7.7 Function of Filter

Filters are used to reduce or filter the a.c. components in the output of a rectifier. Filter is a circuit which reduces the a.c. component from the output of rectifier. *A filter circuit is a device which removes the a.c. components of rectifier output but allows the d.c. component to reach the load.*

Generally a filter circuit should be installed between the rectifier and the load

### 7.7 Different types of filters

A filter circuit is generally a combination of inductor (L) and capacitor (C). The filtering action of L and C depends upon the basic electrical principles.

Filters used in rectifiers are of following types. a) Capacitor filter  
b) Choke input filter c) Capacitor input filter or  $\pi$ -Filter.

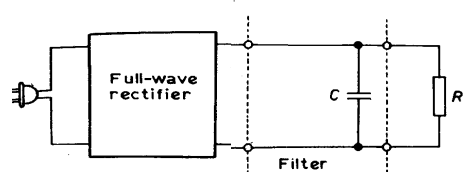

Fig.7.8 Shunt Capacitor filter

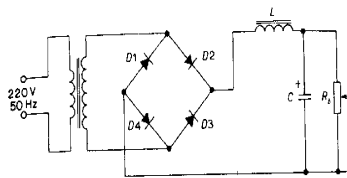

Fig 7.9 Choke input filter

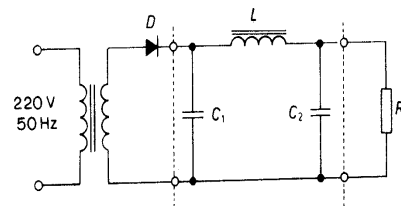

Fig 7.10 Capacitor input or  $\pi$  Filter

## 7.8 Zener Diode

In many electronic applications, it is desired that the output should remain constant regardless of the variations in the input voltage or load. In order to ensure this, a voltage stabilizing device, called voltage stabilizer is used. Zener Diode is one of the voltage stabilizer.

*A properly doped crystal diode which has a sharp breakdown voltage is known as Zener Diode.*

- (i) A Zener diode is like an ordinary diode except that it is properly doped so as to have a sharp breakdown voltage.
- (ii) A Zener diode is always reverse connected i.e. it is always reverse biased.
- (iii) A Zener diode has sharp breakdown voltage called Zener voltage,  $V_z$ .
- (iv) When forward biased, its characteristics are just that of ordinary diode.
- (v) The Zener diode is not immediately burnt just because it has entered the breakdown region. As long as the external circuit connected to the diode, it limits the diode current to less than burn out value, the diode will not burn out.

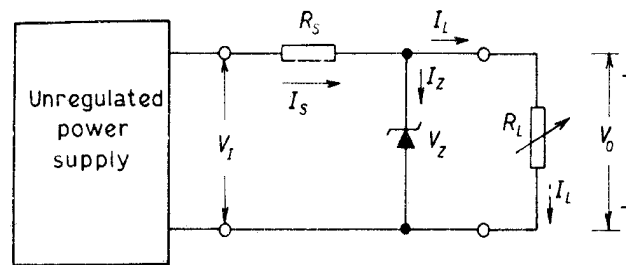

Fig 7.11 Zener Diode Symbol and Practical use

### 7.9 The function of Zener diode as voltage regulator/Stabilizer.

A Zener diode can be used as a voltage regulator to provide a constant output from a source whose voltage may vary over a small range.

The circuit arrangement is shown above fig.(7.11). The Zener diode of zener voltage  $V_z$ , is reverse connected across the load  $R_L$  across which constant output is desired. Suppose the input voltage  $E_{IN}$  exceeds the zener voltage  $V_z$ , this brings the Zener diode in the breakdown region.

Consequently, the excess voltage is dropped across the series resistance  $R_s$ . Now the Zener conducts current  $I_z$ , so that the total current  $I(I_z + I_L)$  flowing through  $R_s$  cause the excess voltage drop across it. Conversely, if supply voltage  $E_I$  falls the current  $I_z$  also falls and the voltage drop across  $R_s$  is reduced. Because of the self adjusting voltage drop across  $R_s$  the output voltage fluctuates to a much lesser extent than the input voltage variations.

### 7.10 Inverter

Inverter is a circuit /equipment which converts dc power into ac power at desired voltage and frequency.

There are two types of Inverters

a) Electronic or solid state inverters. b) Electromechanical inverters.

Each type has its own advantages and limitations. Here we get some fundamental information about electronic inverter i.e., the inverter designed with electronic/solid state components like SCR, MOSFET, IC's etc., Now a days usage of Inverter has being increasing. Because, it reduces the problem of power failure, power cut etc., And also its operation is quite noiseless, Automatic and require very least maintenance when compared with electro-mechanical inverter and AC generator.

Apart from domestic/office use, the inverters are widely used in variable speed ac drive, induction heating, air-craft power supply, UPS etc., An Inverter is used to provide un-interrupted 220V, AC supply to the load connected at its output socket. Inverter also provides (for limited time) constant AC supply at its output socket even when the AC mains supply is not available.

The basic block diagram of common inverter unit is as shown below.

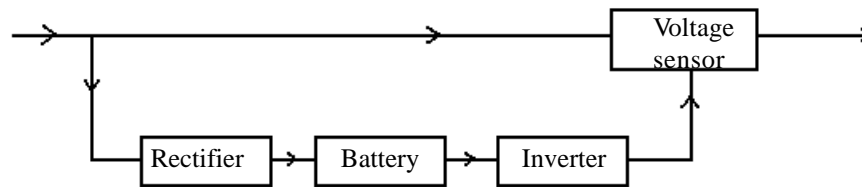

Fig 7.12 Block diagram of simple Inverter

When the main supply is available, voltage sensor reacts and simply passes the AC main supply to the output socket of Inverter directly. Meanwhile some part of AC main supply is converted to DC by rectifier and stored in battery.

On interruption/failure of main AC supply, voltage sensor reacts and activates the function of inverter circuit. The DC power stored in battery is converted into AC and supplied to the output socket of Inverter.

### Working of Simple Inverter

The circuit diagram shown in Fig 7.13 shows the connections of half-bridge type inverter circuit. It consists of two SCR's and a centre tapped inverter transformer and DC source (battery). Two SCR's alternately triggered by oscillator section. Resulting SCR-1 will conduct the current from battery (DC source) for half the time period and it flows through the primary of inverter transformer. Similarly during next half time period of a cycle, SCR-2 will conduct in opposite direction to earlier half cycle and it obtained at secondary of inverter transformer. The output is square or rectangular wave shape. For smooth operation and controlling and sinusoidal output - transistors, MOSFET's, IC's etc., are connected in practical Inverter.

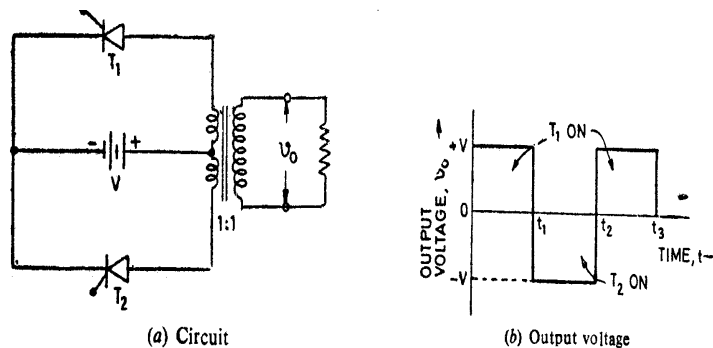

Fig.7.13 Circuit diagram of Half-bridge type Inverter

### 7.11 Un interruptable Power Supply (UPS)

UPS (Un interruptable Power Supply) is an equipment which provides spike free, distortion free, noise free and stabilized power supply to the load. It is connected in series between mains supply and load. It also supply electric power for a limited period (stand by source) in case any failure of mains supply till the arrangement of alternate supply.

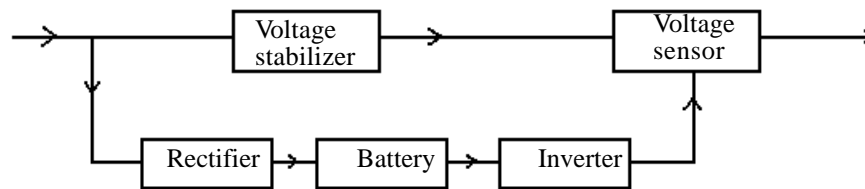

Fig. 7.14 Block diagram of UPS

The standard UPS consists of surge suppressor, automatic voltage regulator charger circuit, battery, inverter and changeover/transfer mechanism.

When the AC supply is available, it is filtered/regulated by surge suppressor and automatic voltage regulator and passed to the load through voltage sensor/changeover switch directly. Mean while some part of AC is converted into DC by rectifier and stored in storage battery.

On interruption/failure of mains AC supply, voltage sensor reacts and activates the function of inverter. The DC power stored in battery is converted to AC by inverter and supplied to the load through voltage sensor/changeover switch.

Thus UPS provides smooth and interruption free AC supply. Basically UPS systems are two types.

- a) Stand-by UPS
- b) On line UPS

The stand-by UPS are economical and low KVA rating(0 to 15 KVA).In this type the inverter starts its function on failure of AC mains supply. Where as in On-line UPS, the inverter is always 'ON' and they are available upto 5000KVA rating.

## 7.12 Servo Voltage Stabilizer

Many electrical/electronic equipments needs constent voltage for their smooth, accurate and safe operation. For that reason voltage stabilizers are became an important part of electrical/electronic equipment. Voltage stabilizers are many types. Out of them the following four types are important.

1. Zenar diode voltage stabilizer.
2. Manuel or non-automatic voltage stabilizer.
3. Automatic voltage stabilizer.
4. Servo voltage stabilizer.

### Servo Voltage Stabilizer

The servo voltage stabilizer provides a smooth and constent output voltage with in a permissable variations in the input voltage. The main components/parts are Auto transformer, Servo motor, voltage sensing circuit, indicators and control switches.

When the input voltage is equal to the preset output voltage, the voltage sensing circuit will be inactive. If the value of output voltage is varied due to some reasons, the voltage sensing circuit immediately reacts and drives the servo motor. It adjusts the position of sliding terminal/arm on auto transformer in order to get constent voltage at output terminals with associate action of buck-boost transformer.

The voltage sensing circuit made by relays, transistors and other electronic components.

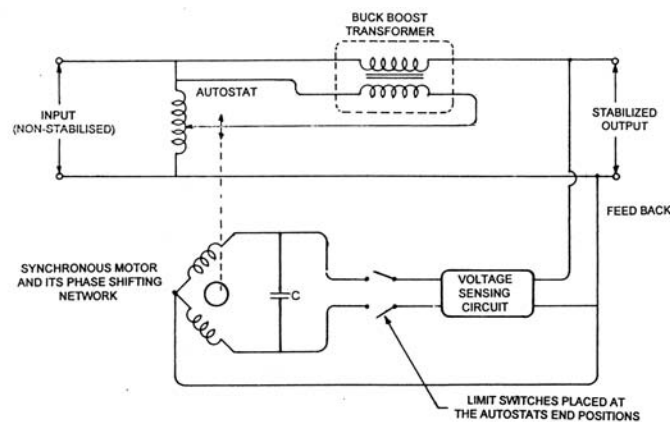

Fig. 7.15 Servo voltage stabilizer

**Questions for evaluation :**

1. Name the different types of power supplies.
2. Draw the block diagram of power supply unit and explain about each block.
3. Define rectifier and name different types of rectifiers.
4. Explain the construction and working of Half wave rectifier.
5. Explain the construction and working of Full wave rectifier by using centre tap transformer.
6. Explain the construction and working of full wave bridge rectifier.
7. Define filter and list the different types of filters used in Rectifiers.
8. Draw the circuit diagram for shunt capacitor filter,  $\pi$  - filter, L-C filter
9. Explain the operation of zener diode as voltage stabilizer.
10. Explain about servo-voltage stabilizer.
11. Draw the block diagram of Inverter.
12. Write a short notes on UPS.

# 8. AMPLIFIERS

## 8.1 Basic concept on Amplifiers

Almost no electronic system can work without an amplifier. If a PA system (Public address system) fails, the voice of a singer or melody of the orchestra can't reach the audience in Auditorium. The signal picked up by microphone is enlarged/amplified by an AF amplifier and passed on to a loud speaker. The loud speaker converts the amplified signal to sound wave. In similar manner, the weak signals received by the radio antenna are amplified by RF amplifier. In televisions, the VHF signals received by the antenna were amplified by VHF amplifier. These amplified signals fed to different circuits to produce audible sound or good quality picture.

*Amplifier is an electronic circuit which rises the strength of a weak signal applied at its input terminals and produces amplified/magnified output at its output terminals by utilizing the DC power applied to it.*

The power in the output signal is approximately equal to the sum of the power of input signal and dc power consumed by that amplifier.

## 8.2 Classification of Amplifiers

Amplifiers are classified in various ways. The classification based on various aspects is given below.

- A) According to their primary function.
  1. Voltage amplifiers.
  2. Current amplifiers.
  3. Power amplifiers.

B) According to the frequency range of operations.

1. Audio frequency amplifiers or AF amplifiers (20 Hz to 20 KHz)
2. Intermediate frequency amplifiers or IF amplifiers (455 KHz)
3. Very High frequency amplifiers or VHF amplifiers (50 Hz to 6MHz)
4. Radio frequency amplifiers or RF amplifiers (30 KHz and above)

C) According to choice of the condition of operation.

1. Class A amplifier
2. Class B amplifier
3. Class C amplifier
4. Class AB amplifier

D) According to method of coupling.

1. RC coupled amplifier.
2. LC coupled amplifier.
3. Transformer coupled amplifier.
4. Direct coupled amplifier.

### 8.3 Operation of Transistor as Amplifier.

A transistor can perform a number of other functions, but it is mainly used in amplifiers to magnify (amplify) the weak electrical signals. The following circuit arrangement shows a basic common base amplifier with NPN Transistor.

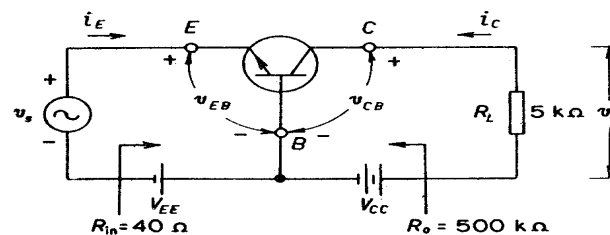

Fig 8.1 Transistor as amplifier

Here the input is applied at emitter base junction (E/B Junction) and the output is taken from collector base junction (C/B junction). The E/B junction is forward biased and the C/B junction is reversed biased. When the signal  $V_s$  is superimposed on the dc voltage  $V_{EE}$ , emitter base voltage  $V_{EB}$  varies with time resulting current  $I_E$  also varies. This produces similar variations in collector current. This varying current passes through load resistance  $R_L$  and develops varying voltage at  $R_L$  (as  $V_o$ ). The output signal voltage  $V_o$  is many times greater than the input signal voltage  $V_s$ . The transistor's amplifying action is basically due to its capability of transferring its signal current from low resistance circuit to high resistance circuit.

### 8.4 Gain, bandwidth and distortion

**Gain** : The ratio of magnitude of output of an amplifier to the magnitude of input signal is called Gain. It is measured in decibels. There are three types of gains in connection with amplifier, such as Current gain, Voltage gain, ( $A_v$ ), Power gain ( $A_p$  ).

The gain of a multi stage amplifier is equal of the product of individual gains of each stages in that amplifier.

**Bandwidth** : The range of frequency in which a transistor amplifier can amplify is called bandwidth.

**Distortion** : The change in shape of output wave compared with the input wave is called distortion.

### 8.5 Biasing

The method of application of DC voltage at various junctions of a transistor to get faithful amplification is called transistor biasing. By proper biasing of a transistor, a desired quiescent operating point (Q- point) is obtained.

There are different methods for biasing a transistor.

- i) Fixed bias or base bias      ii) Collector to base bias
- iii) Emitter bias or self bias    iv) Voltage divider bias

### 8.6. Stabilization and Stability factor

The process of making operating point independent of changes in temperature or changes in transistor parameters is known as Stabilization. The rate of change of collector current ( $I_c$ ) with respect to the reverse saturation current  $I_w$  is called stability factor when  $\beta$  and  $I_B$  are kept constant.

$$\text{Stability factor } S = \frac{dI_c}{dI_{co}}$$

If S = high- poor stability

low- good stability

#### Causes of instability :

The transistor amplifier fails to provide faithful amplification and driven into instability state due to

- i) Change in collector current due to temperature changes
- ii) Thermal runaway
- iii) Replacement of transistor by another/equivalent transistor.

### 8.7. Thermal runaway

The flow of collector current  $I_C$  produces heat within the transistor. This increases the transistor temperature and also the leakage current. This again causes for more heat in transistor. If this continues, within a second the transistor will be damaged. This self destruction of an unstabilized transistor is known as thermal runaway. This can be eliminated/reduced by selecting suitable operating point and providing heat sinks.

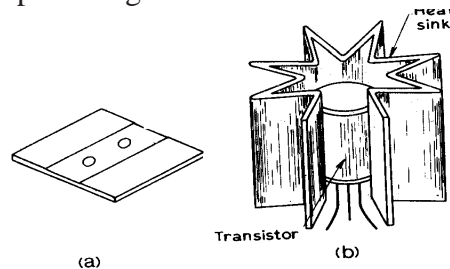

Fig 8.3 Heat Sinks

### 8.8. Methods of transistor biasing

For proper operation of a transistor in any circuit, the transistor biasing is very essential. There are four methods of biasing.

- i) Fixed bias or base bias
- ii) Collector to base bias
- iii) Emitter bias or self bias
- iv) Voltage divider bias.

**i) Fixed bias :** In this method, a high resistance  $R_B$  is connected between the base and positive end of supply. A NPN transistor connected in CE mode shown fig. (for PNP, the resistance  $R_B$  should be connected between base and negative end of supply). It makes base positive with respect to emitter junction is to forward biased.

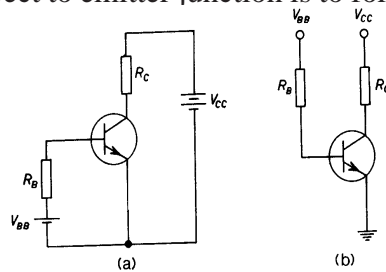

Fig 8.4 Fixed bias

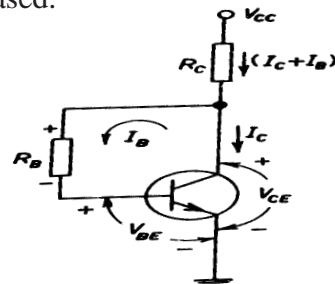

Fig 8.5 Collector to base bias

**ii) Collector to base :** In this method, the bias voltage is obtained from the collector of the transistor by connecting resistance  $R_B$  between base and collector as shown in fig.

The value of  $R_B$  can be calculated by using following relation.

$$R_B = \frac{V_{CC} - V_{BE} - \beta I_B R_C}{I_B}$$

This type of connection provides good feedback but suffers a loss of voltage gain.

iii) **Emitter bias or self bias** : This type of connection is used where  $R_C$  is very small ( transformer coupled amplifier). The  $R_E$  provides negative feed back and causes for stability. But  $R_E$  should be high or  $R_B$  be very low and results further losses and complications. Hence this type of connection is not in use.

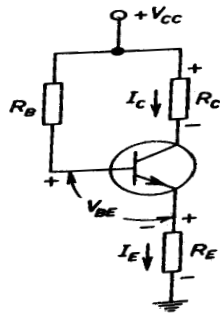

Fig 8.6 Emitter bias or self bias

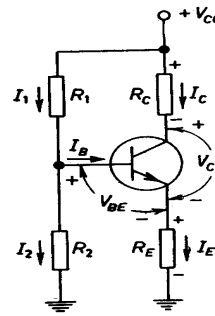

Fig 8.7 Voltage divider bias

iv) **Voltage divider bias** : This is most commonly used biasing method. It gives a stable operating point. Here  $R_1$  and  $R_2$  are voltage dividers,  $R_C$  load resistance and  $R_E$  for stabilization. The voltage drop across  $R_2$  provides a proper forward bias to C/B junction. This method used only single power source for E/B and C/B junctions.

## 8.9. Multistage amplifiers

An amplifier is the basic building block of most electronic systems. A single stage amplifier is not sufficient to build a practical electronic system. The level of signal can be raised by using more than one stage. When a number of amplifier stages are used in succession, it is called multistage amplifier. In a multistage amplifier, the output of one stage is applied to another stage (as in put) through a coupling network. Based on the coupling methods, there are four types of multistage amplifiers.

- 1). RC coupled amplifier
- 2). Inductive/Impedance coupling
- 3). Transformer coupled amplifier
- 4). Direct coupled amplifier

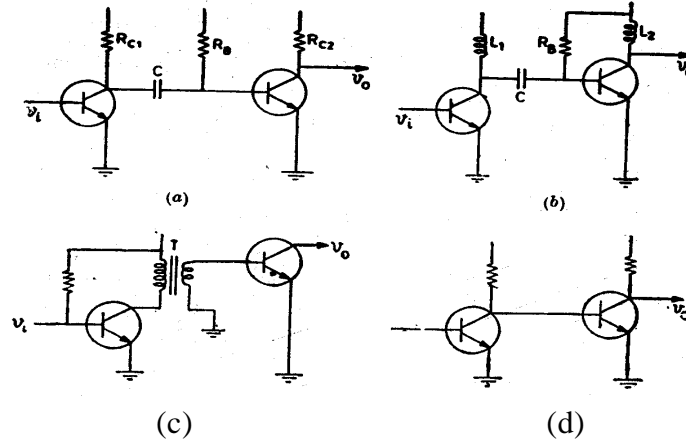

Fig 8.8 Coupling methods of amplifiers

**8.10 RC coupled amplifier**

It is also known as capacitive coupling. Amplifiers using this type of coupling is called **RC** coupled amplifier. The **RC** coupling network consists of two resistors and one coupling capacitor. The function of **RC** network is to pass ac signal from one stage to next and to block the passage of dc voltages from one stage to another. It is most convenient, least expensive.

RC coupling is used in record players, tape recorders, PA system, radio receivers, TV's etc. It also provides uniform amplification over a wide range of frequency ( few hertz's to few mega hertz's)

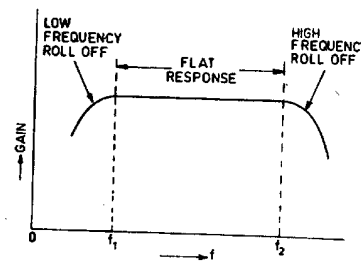
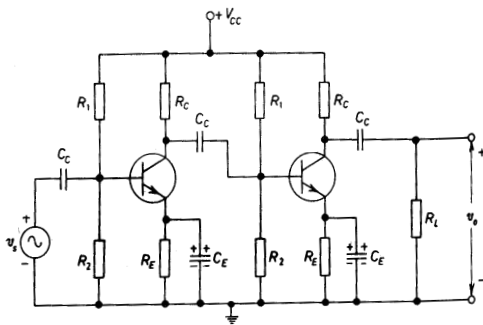

Fig 8.9 (a) RC coupled amplifier

(b) Frequency response of amplifier

### 8.11 Impedance coupled amplifier

It is also known as choke capacitance coupling. Amplifiers using this coupling are known as impedance coupled amplifier. The coupling network consists of  $L_1$ ,  $C_E$  and  $R_B$ . The impedance of coupling coil depends on its inductance and signal frequency. It can be operated at low collector voltage. But it suffers many drawbacks such as poor frequency characteristics, heavy weight and more costly compared with other types, etc., Hence it is rarely used.

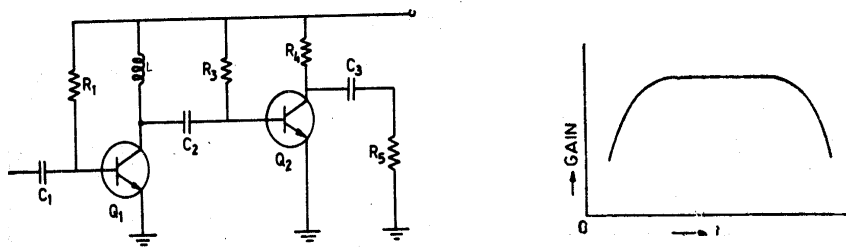

Fig 8.10 (a) Impedance coupled amplifier

(b) Frequency response

### 8.12 Transformer coupled amplifier

In this type of coupling a transformer is used to transfer the ac output voltage of the first stage to input of second stage. The ac voltage across the Primary winding is transferred to secondary winding and to next stage. Because of low resistance of transformer winding, it offers minimum voltage drop at collector and reduces power loss and also helps for proper impedance matching. But, introduction of transformer in the circuit causes more bulky. It can't amplify the signals of different frequencies. It is most suitable for RF signals.

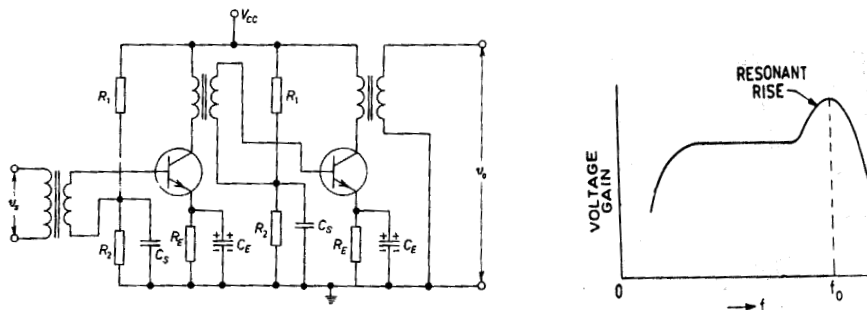

Fig 8.11 (a) Transformer coupled amplifier

8.11 (b) Frequency response

### 8.13 Direct coupled amplifier

If the signal voltages are of low frequency/less magnitude this type of coupling is used. In this type, the output of one stage is directly connected to input of next stage. The circuit shows, two transistors directly couple in CE mode. The circuit arrangement is simple and less expensive.

It can amplify ac and dc signal (less than 10Hz). But it can't amplify high frequency signals and has poor stabilization. Basically it is used in Regulated electronic power supplies, electronic instruments, like thermocouples, pulse amplifier, computer circuitry etc.

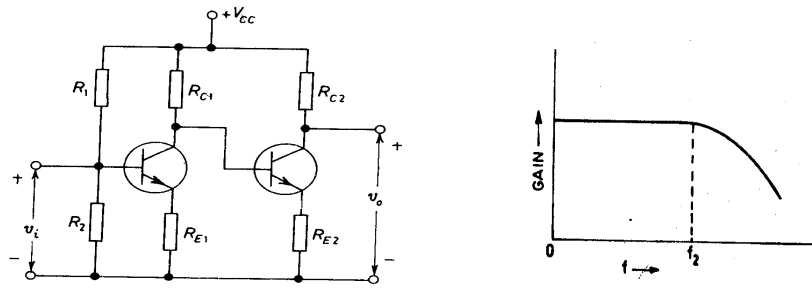

Fig 8.12 (a) Direct coupled amplifier.

Frequency response of direct coupled amplifier

### 8.14 Power amplifier

The main purpose of power amplifier is to boost the power level of input signal. A power amplifier delivers high power, handles large current and has more gain.

There are different types of power amplifiers. such as

- a) Class - A
- b) Class - B
- c) Class - C
- d) Class AB
- e) Push -Pull amplifier
- f) Complementary symmetry push pull amplifier .

### 8.15 Class - A Power amplifier

If the transistor current flows at all times during to full cycle of signal. Then that amplifier is called class - A power amplifier. The class A power amplifier gives the faithful reproduction of input signal without any cut-off in the input signal with least distortion. A transformer is connected as load in collector circuit. It produces good impedance matching and transfers maximum power to the load (i.e, load speaker ). The overall efficiency is 35%.

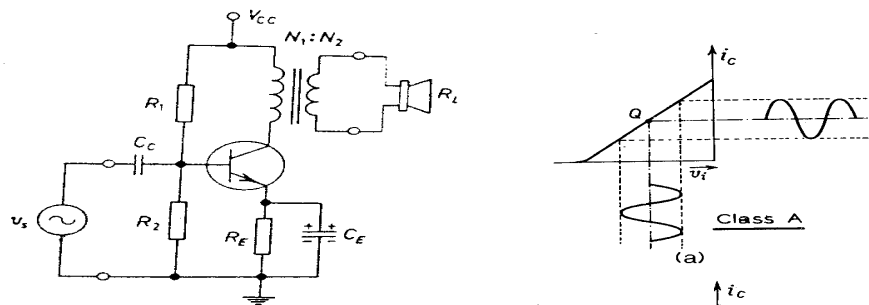

Fig 8.10 Class A power amplifier

### 8.16 Class - B Power Amplifier

If the collector current flows during the positive half cycle of the input signal only, it is called Class - B power amplifier. The basic construction of class - B amplifier is as shown in the circuit. A diode is connected in addition to the transformer in the load circuit

During the positive half cycle, diode is forward biased and conducts/ allows the signal. But at the negative half cycle of signal, the diode is reverse biased and negative half cycle is clipped. In other words, the output is similar to half wave rectifier output.

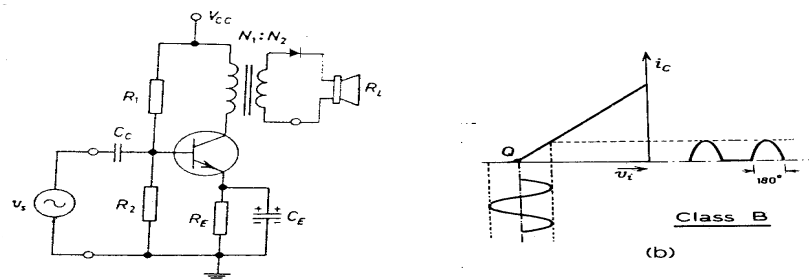

Fig 8.11 Class - B power amplifier

### 8.17 Class - C Power amplifier

If the collector current flows less than half cycle of input signal it is called Class - C amplifier. The basic connections of Class - C amplifier is as shown in fig. The negative half cycle of signal is clipped and even the positive part is reduced to some extent due to the resistance  $R_C$  in collector circuit.

**Applications :** This type of amplifier is used in tuned amplifier circuits.

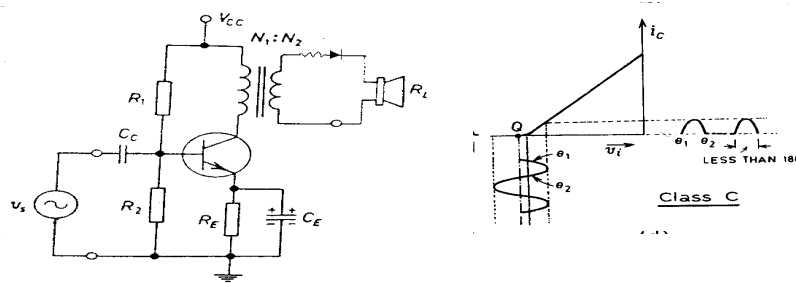

Fig 8.12. Class - C power amplifier

### 8.18 Comparison between voltage amplifier power amplifier

S.No	Voltage amplifier	Power amplifier
1)	The primary function of voltage amplifier is rise the voltage level of the signal.	1) The purpose of power amplifier is to boost the power level of input signal.
2)	It is designed to achieve the largest possible voltage gain.	2) It is designed to achieve the biggest possible power gain
3)	The power in the signal is very less	3) The power in the signal is very large.
4)	The transistor used in voltage amplifier have low power disipation.	4) The transistor used in high voltage amplifiers has high power disipation.
5)	The first stages of a multi stage amplifier voltage amplifier.	5) The final stage of a multi stage amplifier is power amplifier.
6)	These are called small signal amplifier.	6) These are called large signal amplifier.

### 8.19 Class - AB amplifier

This operation is between class A and B. The transistor is in active region for more than half the cycle but less than the whole cycle. The output current flows for more than  $180^\circ$  but less than  $360^\circ$ .

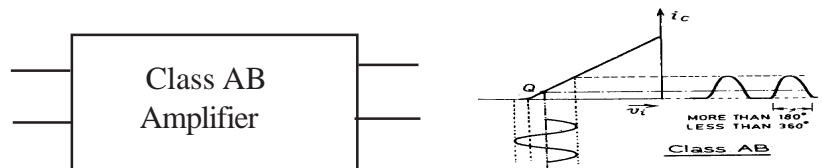

Fig 8.13 Basic Structure and Function of Class - AB Power Amplifier

### 8.20 Push pull amplifier

A push pull amplifier circuit - uses two transistors. This circuit can work in class - B, class AB or Class A mode. It provides low distortion, high efficiency. It is frequently used in output stages of audio stages of transistor receivers, tapes recordors, P A Systems etc.,

The circuit uses two transistors A and B and two transformers such an *input transformer and out put transformer*. The input transformer has centre tap at secondary winding and provides opposite polarity signals to two transistors. The primary of output transformer is centre tapped. The load is connected at the output transformer as shown in fig

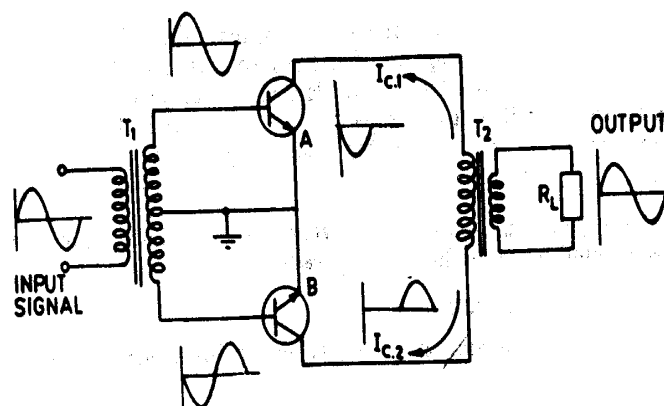

Fig 8.14 Push pull amplifier.

When an ac signal is applied to the input-opposite phased, varying base currents flow in the two transistors with the help of input transformer. The both signals amplified and get collected at output transformer and transferred to load. When one transistor is driven in to more conduction, the other is driven in to less conduction. Hence it this type of amplifier is called push pull amplifier

#### Advantages and disadvantages

- 1) It has high efficiency 75%.
- 2) It has less distortion

- But
- 1) It is bulky and needs two transformers.
  - 2) It needs two transistors.

#### 8.21 Complementary Symmetry Push-pull Amplifier

The basic connections of complementary symmetry push-pull amplifier shown below. Basically it is a push pull amplifier. It uses closely matched but oppositely doped power transistors. One is PNP and the other is NPN type. When input and signal is positive going Transistor- A is biased into conduction and Transistor - B is driven in to cutoff and vice versa. In other words when one transistor is ON the other is OFF. Hence it is also called push pull amplifier.

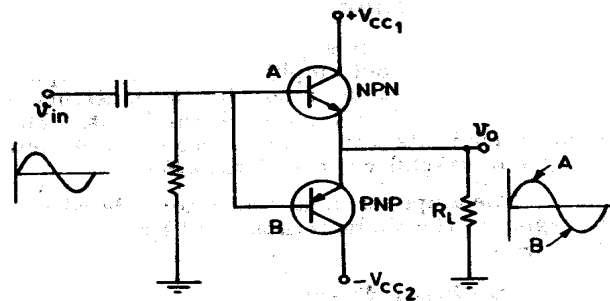

Fig 8.15 Complementary Symmetry Push-pull Amplifier

It has unity voltage gain, no phase inversion and output is high compared with input transistor.

Because of elimination of transformers its weight and cost is less.

## 8.22 Feedback amplifiers

A feedback amplifier is that in which a fraction of the output of an amplifier is fed back to the input circuit to control the output. If the feed back is inphase with input voltage, then it is called positive feed back or re-generative or direct feedback. If the feed back is opposite to input, then it is called negative feed back or de-generative feed back or inverse feed back.

The positive feedback is used in oscillators and negative feedback is used in amplifiers.

## 8.23 Need of feedback in amplifiers

In order to attain the following advantages feedback is necessary in amplifiers. The feed back

- causes High Fidelity
- improves the frequency response
- reduces the distortion and noise
- improves the stability
- modify the input and output impedances as desired.

## 8.24 Basic arrangements of feedback in amplifiers

There are four methods

- a) Voltage - series feed back
- b) Voltage - shunt feed back
- c) Current series feedback.
- d) Current shunt feedback.

The series feedback connections tends to increase the input impedance where as shunt - feed back connection tends to decrease the input impedance. The basic connection and as shown below.

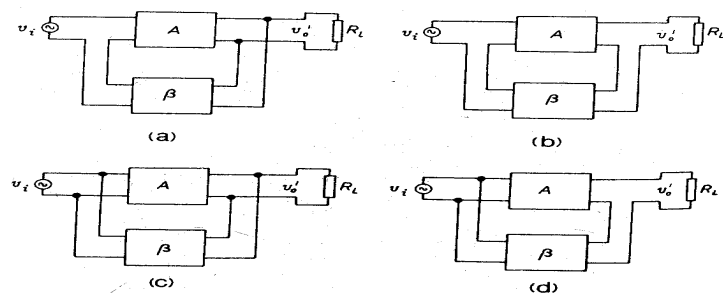

(a) Series-voltage feedback; (b) Series-current feedback;  
(c) shunt-voltage feedback; (d) Shunt-current feedback.

Fig 8.17 . Arrangement of feedback in amplifier.

### 8.25 Comparison between degenerative(negative) feed back and regenerative (positive) feedback.

Negative feed back or Degenerative feed back	Positive feed back or Regenerative feedback
1. The feed back applied is decreases the input.	1. The feedback applied will increases the input.
2. The feedback is $180^\circ$ out of phase with input.	2. The feedback is inphase with input.
3. The distortion in output due to negative feed back is comparitively less.	3. Due to positive feedback, more distortion in output.
4. This type of feedback is used in amplifiers.	4. This type of feedback is used in oscillators.
5. This is also called as inverse feedback.	5. This is also called as direct feedback.

#### Questions for evaluation

1. How the amplifiers can be classified ?
2. How a transistor amplifier the weak signal ? Explain in detail.
3. Define transistor Biasing and inention the types of biasing.
4. Define stability and mention the causes of instability.
5. Define thermal runaway.
6. Write the usual methods of amplifier coupling and draw the circuit diagrams.
7. Define Gain, bondwidth and distortion.
8. Write about working of RC coupled amplifier ?
9. Compare the voltage amplifier with power amplifier.
10. Explain about push pull amplifier with circuit diagram.
11. Define feed back amplifiers. mention its advanteges.
12. Write the comparision between Degenerative and regenerative feed back amplifiers.

# 9. INTEGRATED CIRCUITS

## 9.1. Introduction

The circuits discussed so far consist of separately manufactured components such as Resistors, Diodes, Transistors, Capacitors, Inductors etc., They are joined by wire or soldered to a printed circuit board. Such circuits are known as discrete circuits because each component in the circuit can be separated from others. Discrete circuits have two main disadvantages such as it requires more space, there may be so many soldered points. Considering these problems, integrated circuits are developed.

The first integrated circuit was developed by J.S.Kilby in 1958. Since then various industries have developed a large number of standard integrated circuits.

### **What is an Integrated circuit?**

An IC is a packaged electronic circuit. It is a complete electronic circuit in which both the active and passive components are fabricated on an extremely tiny single silicon chip.

(Active components - Transistors, FET's, Diodes etc,  
Passive components - Resistors, Capacitors, inductors etc.)

## 9.2. Advantages of IC's

IC's have many advantages when compared with discrete circuits.

1. **They occupy very small space** : This is due to fabrication of various circuit elements on a single chip of 15 mm thick.

*Chip* : An extremely small part of silicon wafer on which IC is fabricated. One silicon wafer of 2cm dia, may 200 mm thick contain 1000 IC chips.

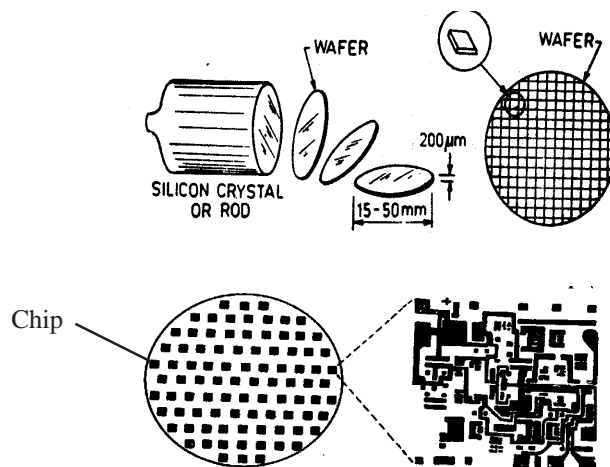

Fig 9.1 Basic structure of chip

2. **Their weight is very less** : Generally a single chip may contain 50 to 300,000 components. Hence their weight is very very less compared with discrete circuits.

3. **They are available at low cost** : All circuit components are fabricated in or on a single wafer. At the same time hundreds of similar wafers can be produced simultaneously. Due to this type of production (called mass production), an IC costs less compared with discrete components.

4. **Increased reliability** : It is due to components are fabricated simultaneously and has no soldered joints and smaller temperature rise on operation.

5. **Low power consumption** : IC's require less power for its operations. Because the circuit components are smaller in size.

6. **Increased performance** : The overall performance of IC is more than discrete circuit. It is faster and can withstand extreme temperatures. And performs functions which are impossible by conventional circuits.

7. **Easy replacement** : It is easy to replace an IC. Because they are being fabricated in single line, dual line plastic package. Hence they can be plugged in to the IC socket directly.

**9.3. Dis-Advantages of IC's**

The integrated circuits suffer with the following draw-backs.

1. Fabrication of inductor on IC is difficult
2. It is not possible to fabricate a Transformer on IC.
3. IC can't be repaired in case of failure.
4. They function at low voltages only.
5. They are delicate and can't withstand rough handling or excessive heat.
6. They handle only limited amount of power.

**9.4. Classification of Integrated circuits.**

The integrated circuits can be classified in to three groups.

- A. Classification based on the level of integration.
- B. Classification based on the method of manufacturing.
- C. Classification based on the area of applications mode of operation.

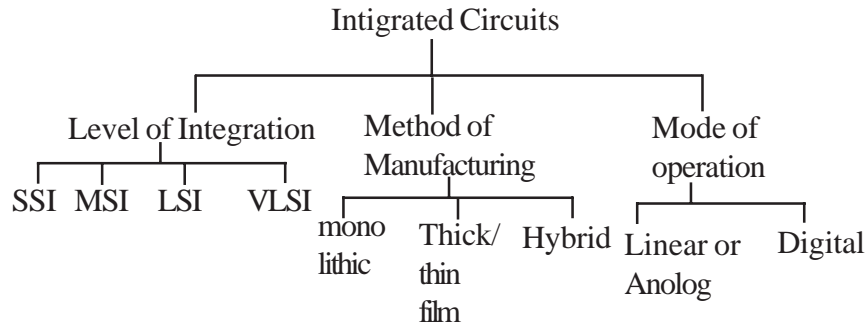

**A. Classification of IC's based on the level of Integration.**

This type of classification is based on number of electronic components or circuits per IC package.

This type of classification is as explained below.

- a) **Small scale integration (SSI)**. The number of circuits per IC is varied upto 30 or net no. of components are less than 50.
- b) **Medium scale Integration (MSI)**. Here the numberof circuits per IC package is varied between 30 to 100 or 50 to 500

- c) **Large scale integration (LSI).** The no. of circuits per IC package for this type of integration is varies between 100 to 100,000 or 500 to 300 000 components.
- d) **Very large scale Integration (VLSI) :** It is very large level of integration. The number of circuits per each silicon wafer is more than 1,00,000.

### **B. Classification of IC's based on the method of manufacturing.**

The IC's can be classified in to three groups on their method of manufacturing/fabrication. They were

a) *Monolithic IC's* : In this, all the circuits/components are fabricated on single silicon wafer. Transistors, diodes, resistors, capacitors etc., are fabricated appropriate spots in the wafer. This type of IC's are in wide use and also most economical.

b) *Thick and thin film IC's* : The physical size and shape of thick and thin film IC's is same. But there is a lot of difference in characteristics and method of fabrication.

This type of IC's accomidates only passive components like resistors, capacitors etc.

c) *Hybrid IC's or multi chip IC's* : This type of IC can be formed by a number of interconnected individual chips/wafers or by combination of film and mono lithic IC techniques. So that, all the components active and passive components can be fabricated in a single IC.

### **C. Classification of IC's based on applications/mode of operation.**

IC's can be classified in to two groups according to their mode of operation and applications. They were

- a) Linear IC's
- b) Digital IC's

a) **Liner IC's (LIC's)** : These are also refered as analog IC's. Since, their output is praportional to their input. They are much reliable, fast responding. Linear IC's are equilent to general discrete circuits such as amplifier, filter, oscillator, modulator, demodulator etc.,

The major applications of linear IC's are

- a) Operational amplifiers (CA 741 CT, LM 208)
- b) Small signal amplifiers (9TEA 5591)
- c) Power amplifiers (CA 3020)
- d) RF and IF amplifiers (CA 3065)
- e) Micro wave amplifiers
- f) Multipliers
- g) Voltage comparators CA 741 T
- h) Voltage regulators (ICI 723)

**b) Digital IC's :** This type of IC's are used in computers. But its utilization is extended to other electronic equipments also. Basically digital IC's are mono-lithic type.

Digital IC's contain circuits whose input and output voltages are limited to two levels 'low' or 'high'. The applications of digital IC's are

- a) logic gates
- b) Flip-flaps
- c) Counters
- d) clocks/timers
- e) Calculators
- f) Memory chips
- g) Micro processors.

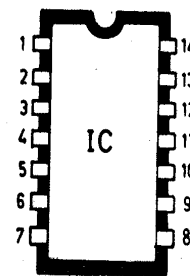
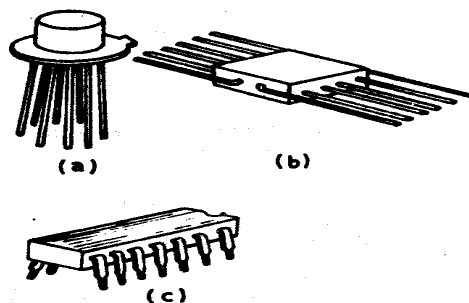

### 9.5 Comparison between Discrete circuits and Integrated circuits.

Discrete circuit	Integrated circuit
1. A circuit which contains components like resistors, capacitors, Transistors, diode, etc is called discrete circuit. They were connected by a wire or soldered to a PCB	1. A circuit which contains resistors, Capacitors, Transistors, diodes etc and fabricated in single silicon chip is called IC.
2. It needs more space as the no. of components.	2. It occupies very less space. More than 3,00,000 circuits can be fabricated on a 15mm dia, 0.2mm thick wafer
3. Weight of a circuit made by a discrete components is more.	3. Weight of an IC is very less.
4. The net cost of a discrete circuit is more	4. The cost of an IC is very less
5. Power loss and power consumption is more.	5. Power loss and power consumption is very less.
6. Reliability is less.	6. Much reliable, faster, accurate.
7. Trouble shooting is easy	7. IC can't be repaired.
8. It can be operated at high voltages.	8. It can't be operated at high voltage.
9. They are rugged type.	9. IC are sensitive.

### 9.6 Identification of IC terminals/pins

After the completion of fabrication of different components on a chip, it is arranged in a package as shown in fig. Usually ceramic packages are used where IC is subjected to high temperature. In general, plastic material is used as package material for IC's. Even though there is a standardize IC terminal connections, various manufacturers use their own systems for pin identification. But most of the manufacturers use the pin diagrams for IC package as shown in fig.

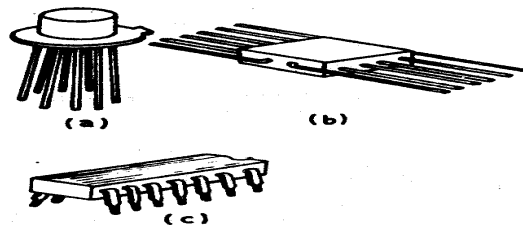

Fig 9.2 Different physical shapes of Integrated Circuits

**Flat package :**

1. Count starts with pin where dot is located
2. Count proceeds in direction as arrow indicated.

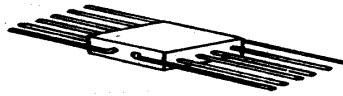

Fig 9.3 Flat pack

**To package :**

1. Count starts with the pin left of the tab.
2. Count proceeds in anti-clock wise direction as arrow indicated.

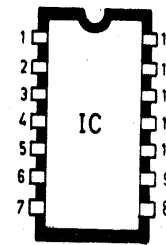

Fig 9.4 To-package-

Fig 9.5 Dual In Line  
Plastic Package**Dual in line plastic package**

1. Count starts with pin which is left of notch
2. Count proceeds as the direction of arrow.

**Questions for evaluation**

1. Define IC.
2. What are the advantages of IC's
3. What are the limitations of IC's
4. Define chip.
5. Classify the IC's
6. Give a detailed note on classification of IC's
7. What are the applications of linear/Analog and digital IC's
8. Compare at least 8 aspects between discrete circuits and Integrated circuits.
9. Mention the types of packages used for IC's.
10. Name 4 IC numbers and write their applications.

## Appendix - I Component Symbols

### CONNECTIONS AND CONNECTORS

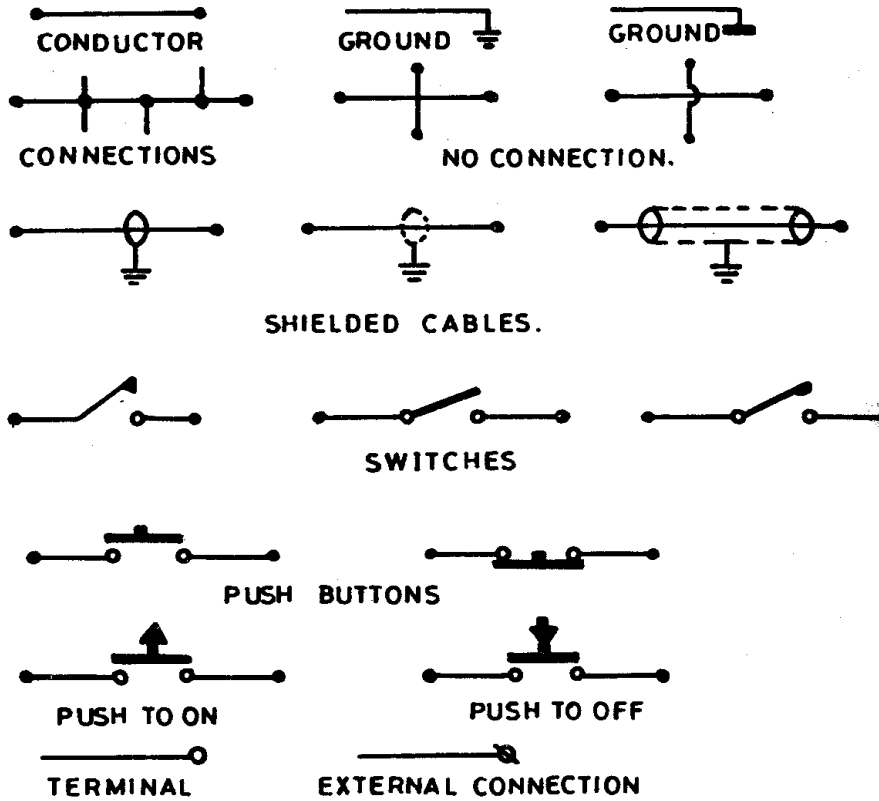

### CELLS



### LAMPS

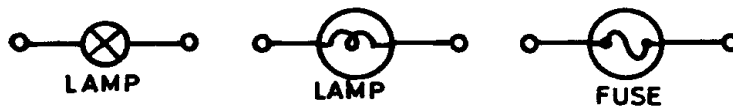

### RESISTANCES

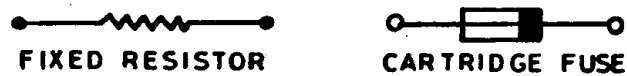

**POSITIVE SENSORS**

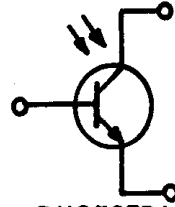
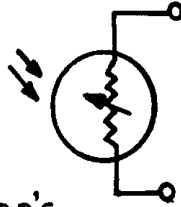
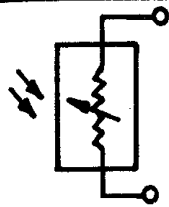

LDR'S

PHOTOTRANSISTORS.

**VARIABLE RESISTANCES**

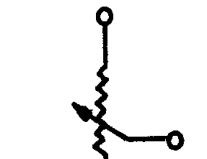

POTENTIOMETER

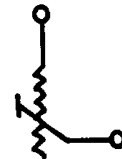

PRESET

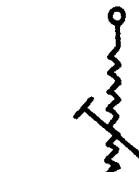

MULTITURN PRESET

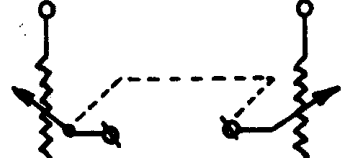

DUAL TANDEM  
STEREO POTENTIOMETER.

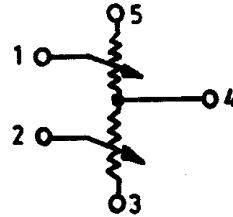

TAPPED POTENTIOMETER

**CAPACITORS**



NON POLAR

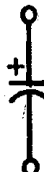

ELECTROLYTIC



BIPOLAR.



**COILS**



COIL



INDUCTOR



WITH  
CORE

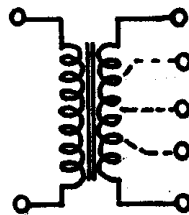

TRANSFORMER

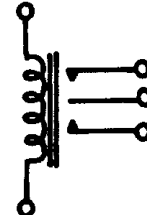

RELAY

**SEMICONDUCTORS**



DIODE



ZENER DIODE

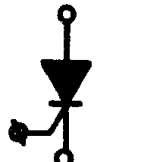

THYRISTOR (SCR)



DIAC.



TRIAC



LED



PHOTO DIODE



7 SEGMENT DISPLAY

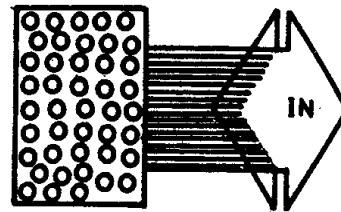

ALPHANUMERIC DISPLAY

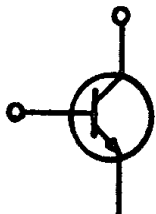

NPN

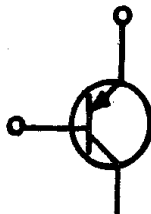

PNP

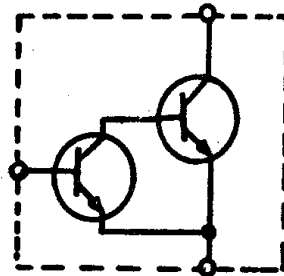

DARLINGTON PAIR

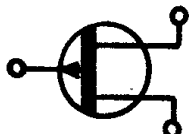

P-CHANNEL JFET

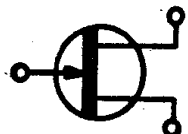

N-CHANNEL JFET

**METERS**



ANALOGUE METER

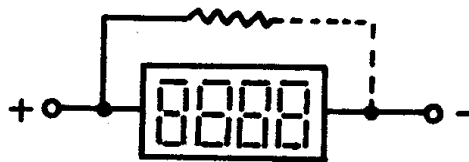

DIGITAL METER

GATES

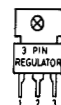
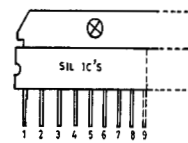
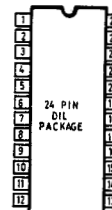
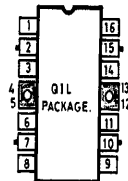
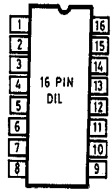
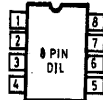
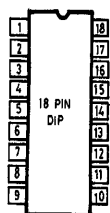
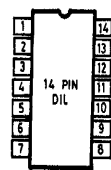
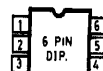
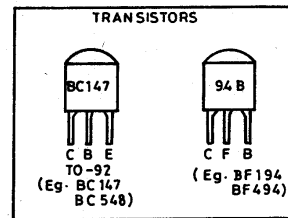
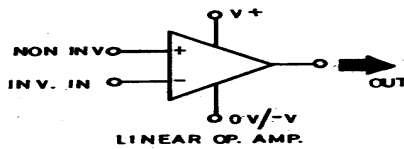
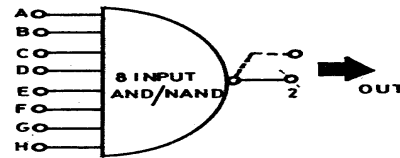
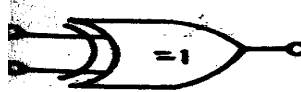
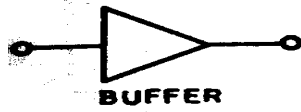
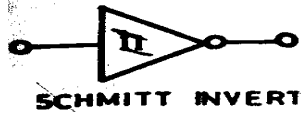

## Resistor Colour Codes

This standard international resistor decoder (code) table allows the value of any resistor to be found instantly.

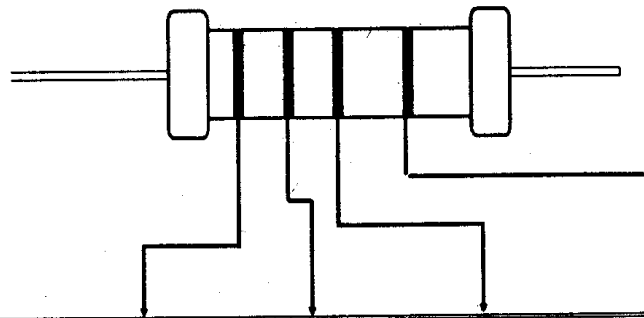

Colour	1st Band	2nd Band	Multiplier	Tolerance
Black	0	0	$\times 1$	
Brown	1	1	$\times 10$	$\pm 1\%$
Red	2	2	$\times 100$	$\pm 2\%$
Orange	3	3	$\times 1K$	
Yellow	4	4	$\times 10K$	
Green	5	5	$\times 100K$	$\pm 0.5\%$
Blue	6	6	$\times 1M$	$\pm 0.25\%$
Violet	7	7	$\times 10M$	$\pm 0.1\%$
Gray	8	8		$\pm 0.05\%$
White	9	9		
Gold			$\times 0.1$	$\pm 5\%$
Silver			$\times 0.01$	$\pm 10\%$

