

IVC
FIRST YEAR

Electronics Engineering Technician

**CIRCUIT THEORY
AND
ELECTRONIC
COMPONENTS**



STATE INSTITUTE OF VOCATIONAL EDUCATION
DIRECTOR OF INTERMEDIATE EDUCATION
GOVT. OF ANDHRAPRADESH

Telugu Akademi Publication : Vocational Course -fyc tec

**INTERMEDIATE
VOCATIONAL COURSE
FIRST YEAR**

**CIRCUIT THEORY
AND
ELECTRONIC COMPONENTS**

*FOR THE COURSE OF
ELECTRONICS
ENGINEERING TECHNICIAN*



STATE INSTITUTE OF VOCATIONAL EDUCATION
DIRECTOR OF INTERMEDIATE EDUCATION
GOVT. OF ANDHRAPRADESH

2005

Intermediate Vocational Course, 1st Year : **CIRCUIT THEORY AND ELECTRONIC COMPONENTS (For the Course of Electronics Engineering Technician)** : Authors : **Sri Peta Subramanyam Reddy**, Editor : **Sri M. Shanmukhachary**, First Edition : 2005.

©
**State Institute of Vocational Education
Andhra Pradesh, Hyderabad.**

*Printed and Published by
the Telugu Akademi, Hyderabad on behalf of the
State Institution of Vocational Education
Directorate of Intermediate Education
Govt. of Andhra Pradesh, Hyderabad.*

First Edition : 2005

Copies :

All rights whatsoever in this book are strictly reserved and no portion of it may be reproduced by any process for any purpose without the written permission of the copyright owners.

Price : Rs. /-

Printed in India
Laser Typeset Reformatted by Chinmai D.T.P. Works, Chittoor.
Text Printed at

Andhra Pradesh.

AUTHOR

Peta Subramanyam Reddy **AMIE**
J.L. in EET
Govt. Junior College, Irala.
Chittoor Dist.

EDITOR

M. Shanmukha Chary
B.Sc., AMIE (I), I.E.T.E. (I)
J.L. in EET
Govt. Jr. College,
Malkajigiri, Secunderabad.

INDEX

<i>S.No.</i>	<i>Topic</i>	<i>Page. No.</i>
1.	<i>Resistors</i>	... 1 - 17
2.	<i>Inductors and Transformers</i>	... 18 -32
3.	<i>Capacitors</i>	... 33 -43
4.	<i>A.C. Circuits</i>	... 44 - 70
5.	<i>Filters</i>	... 71 -83
6.	<i>Micro Phones & Loudspeakers</i>	... 84 -99
7.	<i>Switches, Relays, PCB</i>	... 100 -115
8.	<i>Batteries</i>	... 116 - 121
9.	<i>Model Question Paper</i>	... 122

CHAPTER 1 RESISTORS

1.1. Introduction

In many electronic circuit applications the resistance forms the basic part of the circuit. It is defined as “The property of a substance due to which it opposes the flow of electricity through it”.

Metals, Acids and salt solutions are good conductors of electricity. Amongst pure metals Gold, Silver, Copper and Aluminum are very good conductors in the given order. This is due to the presence of a large number of free or loosely attached electrons in their atoms. These free electrons assume a directed motion on the application of an electric potential difference. These electrons while flowing passes through the molecules or the atoms of the conductor, collide with other atoms and electrons, there by producing heat. Thus substances which offer relatively greater difficulty or hindrance to the passage of these electrons are said to be relatively poor conductors. **Ex :** Bakelite, Mica, Glass, Rubber, PVC, Dry wood etc. Thus the Resistance or electrical friction is similar to Friction in Mechanics. Its symbol is shown in the below fig. 1.1

The unit of resistance is ‘Ohm’. It is denoted by the letter ‘ Ω ’. For measurement of higher values we can use multiples and submultiples. These are shown in the below table 1-1.

Table – 1.1 Multiples and Submultiples of OHM

Prefix	Meaning	Abbreviation	Equal to
Mega	One Million	M Ω	$10^6 \Omega$
Kilo	One Thousand	K Ω	$10^3 \Omega$
Milli	One Thousandth	m Ω	$10^{-3} \Omega$
Micro	One Millionth	$\mu\Omega$	$10^{-6} \Omega$



Fig : 1 .1

The Symbol of resistance

1.2. Types Resistors

The Component which offers a specific value of resistance is called “Resistor”. Basically these are two types. 1. Fixed Resistors, 2. Variable Resistors.

Fixed Resistors are further classified according to the Manufacturing and applications as follows :

1. Carbon Composition Resistors
2. Carbon film Resistors.
3. Metal film Resistors
4. Wire Wound Resistors
5. Thermistors
6. NTC's & PTC's
7. Varistors
8. LDR's
9. Fusible Resistors.

Variable Resistors are classified as follows

1. Carbon potentiometers (Both log and linear potentiometers)
2. Wire Wound Potentiometers.
3. Rheostats.
4. Decade Resistance Boxes.
5. Presets

1.3. Specifications

The different characteristic values of a Resistor or its different ratings are known as “Specifications” of a Resistor.

Generally while purchasing these are very useful. If a person knows the ratings and where it is used he can easily purchase a resistor from the vendor by asking different ratings according to his requirement. For example if a person wants to purchase a control for varying the volume in tape recorder, first he can ask the vendor about the type of resistor (i.e. carbon potentiometer) next he can ask the rating (i.e. resistance value and wattage) like that by asking different

ratings according to one's application and requirement one can purchase Resistors from a shop. Such type of ratings or specifications of a Resistor are as follows.

1. Resistance value in ohms or ohmic value, size and shape.
2. Power or wattage rating in watts.
3. Tolerance
4. Voltage rating or maximum operating voltage
5. Temperature coefficient
6. Noise
7. Reliability

Among these ohmic value, wattage rating and tolerance are important ratings of carbon resistors.

1.3.1. Power or wattage rating

Power rating determines the maximum current that a resistor can withstand without being destroyed. Power dissipation means the power that is wasted as I^2R loss. This is expressed in watts. Carbon resistors are available from 1/8 watt to 2 watts wattage ratings whereas wire wound resistors are available at high power ratings in the order of hundreds of watts.

1.3.2. Colour Code

The carbon resistors are small in size due to this reason these are colour coded to indicate their resistance value in ohms. The dark colours represent the lower value and the lighter colours represent higher values. Each resistor will have four colour bands printed on it as shown in below fig. 1.2. These colours are shown in the table 1.2. The colour bands are printed at one end of the resistor and are read from left to right. The first two bands close to the edge indicate the significant values. These two are the first and second digits of the resistance value. The third colour band indicates the multiplier. This is the multiplying value followed by the two digits or this gives the number of zeros followed by the first two digits. The fourth band indicates the Tolerance Value i.e. it indicates how accurate the resistance is.

For example a resistor will have yellow, violet, orange and gold bands. then the value of the resistor is decoded as follows. The significant value (first two bands) of the resistor is 47 (yellow : 4, violet : 7) followed by multiplier value orange i.e. number of zeros. Then the resistance value becomes 47000 ohms or 47k Ω Thus first three colour bands shows the resistance value of the resistor. Fourth colour indicates tolerance in this case gold indicates $\pm 5\%$. Thus the decoded value of the resistor is 47K $\Omega \pm 5\%$

Table 1.2 : Colour Code Table

S.No.	Name of the Colour	First Band	Second Band	Third Band
1.	Black	0	0	$\times 10^0$
2.	Brown	1	1	$\times 10^1$
3.	Red	2	2	$\times 10^2$
4.	Orange	3	3	$\times 10^3$
5.	Yellow	4	4	$\times 10^4$
6.	Green	5	5	$\times 10^5$
7.	Blue	6	6	$\times 10^6$
8.	Violet	7	7	$\times 10^7$
9.	Grey	8	8	$\times 10^8$
10.	White	9	9	$\times 10^9$
11.	Gold	-	-	$\times 10^{-1}$
12.	Silver	-	-	$\times 10^{-2}$
13.	No colour	-	-	-

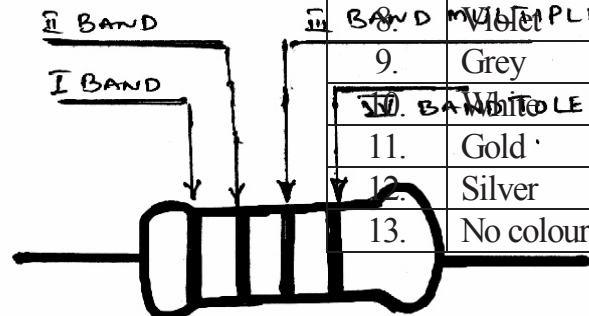

Fig. 1.2

Decoding of Resistor Colour Code

1.3.3. Tolerance

Tolerance is the amount by which the actual resistance can vary from the colour coded value. It is usually specified in percentage. Generally gold, Silver and No colour are used as tolerance. The percentage of these colours are as follows. Gold : $\pm 5\%$, Silver : $\pm 10\%$, No Colour : $\pm 20\%$.

For example if a resistor's colour coded value is $10\text{K}\Omega$ and its tolerance is 10% . It means this resistor's actual resistance can vary $10\text{K}\Omega \pm 10\%$ (i.e. it varies in between $9\text{K}\Omega$ to $11\text{K}\Omega$). Due to this reason we can use this resistor for any value which lies between $9\text{K}\Omega$ to $11\text{K}\Omega$

1.4 Preferred Values

To cater the needs of unlimited variety of electronic circuits and to reduce the manufacturing problem, the values of resistors to be manufactured are standardized. For uniformity of production and easy of replacement, resistors are manufactured only in fixed denominations depending upon the tolerance. These fixed values are known as preferred values. For different tolerance these preferred values are as follows.

For 5% tolerance 10, 11, 12, 13, 14, 15, 16, 17, 18, 20, 22, 24, 27, 30, 33, 36, 39, 43, 47, 51, 62, 68, 75, 83, 91, 100, and their multiples. For 10% Tolerance 10, 12, 15, 18, 22, 27, 33, 39, 47, 56, 68, 82 and their multiples.

1.5 Comparison of wire wound, metal film and carbon resistors

The differences between the above three types of Resistors are shown in the table 1.3

Table 1.3

Carbon Resistors	Metal film Resistors	Wire would Resistors
1 These are manufactured using the carbon granuals mixed with resin, binder and flux	1 These are manufactured by depositing a film of metal alloys on a ceramic or glass body.	1 These are manufactured using Nichrome wires.
2 These are available in high resistance values ranging from $1\ \Omega$ to $10\text{M}\Omega$	2 These are available in low resistance values	2 These are available in the resistance values from $0.1\ \Omega$ to $150\text{K}\Omega$.

3	These are available in the low power ratings ranging from 1/8 watt. To 2 watt.	3	These are available in the low power ratings ranging from 1/8 to 2 w	3	These are available at high power ratings in the order of kilowatts.
4	Carbon resistors occupy less space in circuits due to their small in size	4	These are also occupy less space in circuits due to their small in size.	4	Wire wound resistors occupy more space in circuits due to their larger size.
5	The value of the resistor is coded using colour code.	5	The value of the resistor is coded using colour code.	5	The value of the resistor is printed on it.
6	These are used at high and low frequencies for their noise less operation	6	These are also used for noise less operation at high frequency.	6	These are not used at high frequencies due to noisy operation.
7	These have low current carrying ability.	7	These have low and medium current carrying ability.	7	These have high current carrying ability.

1.6. Carbon and wire wound Potentiometers

The potentiometers which are made of carbon are known as carbon potentiometers and which are made of wire wound are known as wire wound potentiometers. These are all variable resistors. These are used as panel controls in Radio's, Televisions and other Consumer Electronic Circuits and equipments.

1.6.1. Carbon Potentiometer

The potentiometers which are made of carbon are known as carbon potentiometers. It consists of a carbon track which is made with a mixture of carbon, resin and clay on a plastic base as shown in fig1.3. This mixture is pressed and baked in to shape shown in fig. A movable contact can slide on the plastic base. There is a slip ring which is also contacted by the movable contact. The two ends are soldered to lugs forming the terminals, The middle lug is connected to the variable arm contacting the resistance element by a metal spring wiper. As the control shaft is rotated the variable arm moves the wiper to make contact at different points. The connecting shaft is some times made of plastic, runs through the bush in the centre of the base at which the movable contact is attached. The bush is generally provided with screws on the external surface so that the unit can be locked on to the chassis with a lock and nut.

Threading over the bush, the entire assembly is enclosed by a case of sheet metal and its value marked. These are used for low power applications.

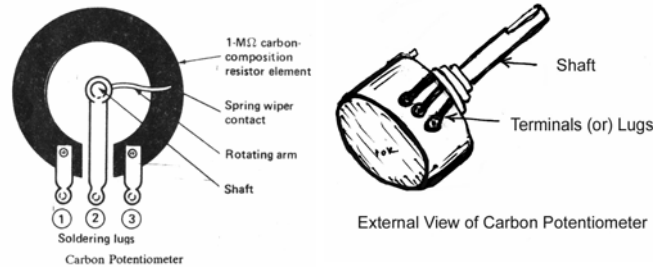

Fig.1.3 carbon potentiometer internal and external views

1.6.2. WIRE WOUND POTENTIOMETERS

In these potentiometers on a flat strip of insulating former Nichrome wire is wound that's why the name "wire wound potentiometer". Then this strip is bent round as a cylindrical surface. Contact by means of a slider metal of beryllium, copper spring loaded may be made on the inside periphery or the outer edge. Contact from the slider may be through a slip ring or by a coiled spring attached to the stationary at one end and at another to the wiper. The winding is usually of two or three linear resistance sections to approximate ideal taper. The formers are made of flat flexible plastics, but now a day anodized aluminum flats are employed. The enclosure may be as in the carbon type of potentiometers or encapsulated after fixing on 'O' type ring seal to the shaft and cladding with epoxy resin enclosure. Its constructional details are shown in the fig. 1.4 .

These are available in 1.5, 2, 3, 4, watts of power ratings. These are used in amplifiers balance controls, small motor controls, servo motor control circuits, Television receivers and analog computers.

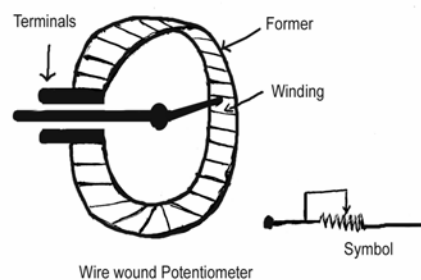

Fig. 1.4

Wire Wound Potentiometer

1.7 Applications of different types of Resistors

In many electronic circuit applications the resistance forms the basic part of the circuit. So the specific areas or applications where these fixed, variable resistors are used is as follows.

1. Carbon resistors are used in all electronic circuits as biasing and signal bypassing elements and as loads.
2. Wire wound resistors are used in voltage control and current control circuits.
3. Carbon potentiometers are used as panel controls like volume, tone, brightness, contrast etc. in Radios, tape-recorders and Televisions.
4. Wire wound potentiometers are used as amplifier balance controls, small motor controls, servomotor control circuits and in Television receivers.
5. Decade resistance boxes are used in laboratories.
6. Thermistors are used in time delay circuits.
7. LDR's are used in DC chopper amplifiers as photo choppers.

1.8 OHMS LAW

George Simon Ohm a German mathematician formulated a relation between voltage and current through a conductor known after his name as Ohms law. This law applies to electric conduction through good conductors. This law is applicable to D.C. circuits as well as A.C. circuits.

Ohms law states that at constant temperature the current flowing through a conductor is directly proportional to the voltage applied between the terminals of that conductor or Ohms law states that the ratio of potential difference between any two points of a conductor to the current flowing between them is constant. Provided the temperature of the conductor does not change.

According to Ohms Law $V \propto I$

or

$$V / I = \text{Constant}$$

(or) $V/I = R$ (Where R is constant of proportionality known as Resistance)

Thus keeping Resistance as constant if we can vary the voltage or current of a circuit directly proportional to current or voltage then such a circuit is known as linear circuit. Thus the circuit or the element which obeys Ohms Law is known as linear circuit or linear element. In this way the relation between the three electrical quantities viz Current, Voltage and resistance in a circuit is known as Ohms law. These electrical quantities are defined as follows.

1.8.1. Current

Current is defined as the flow of free electrons in a conductor (or). It is defined as the rate of change of charge at any cross section of the conductor. It is denoted by the letter I and is measured in Amperes and is denoted by the letter “A” Current $I = dq / dt$

1.8.2. Voltage

The work done to carry an electron or unit charge from one point to another point in a conductor is known as voltage. This is also called as potential difference or electro motive force. It is denoted by the letter V and is measured in Volts.

1.8.3. Resistance

Resistance is the Property of a substance due to which it opposes the flow of electrons or current through it. This is measured by the unit Ohm and is denoted by the letter “ Ω ”

1.8.4. Units and Meters used for Measuring the electrical quantities

The units and meters used for measurement of resistance current and voltage are given in the Table 1.4

Table 1.4

S. No.	Electrical Quantity	Unit	Meter used for Measurement
1.	Resistance	Ohm	Ohm meter
2.	Current	Ampere	Ammeter
3.	Voltage	Volt	Voltmeter

1.8.5 Multiples and Submultiples of electrical quantities

The multiples and submultiples used in measuring the above electrical quantities are also shown in the table 1.5

Table 1.5**1.9. Factors affecting the value of Resistance**

The Resistance offered by a conductor depends on so many number of factors. These are as follows.

1. The Resistance of a conductor is directly proportional to its length L
2. The Resistance of a conductor is inversely proportional to its “Area of cross section” A .
3. The resistance of a conductor also depends on temperature and nature of the Material. Neglecting the last factor for the time being we can say that

$$R \propto L/A \quad \text{or} \quad R = \rho L/A$$

Where ‘ L ’ is the ‘length’, ‘ A ’ is the ‘area’ of cross section of the conductor and ρ is the constant depending on the nature of the material of the conductor. This is known as specific resistance or Resistivity.

1.9.1 Specific Resistance or Resistivity

The Specific resistance of a Material may be defined as the “The resistance between the opposite faces of a meter cube of that material. This is shown in the below figure 1.5. This is denoted by the letter ρ . From the laws of Resistance we know that $R = \rho L / A$. Keeping ρ as subject we can get Specific Resistance $\rho = RA / L$ Unit = Ohm x $\text{m}^2 / \text{meter} = \text{ohm meter}$.

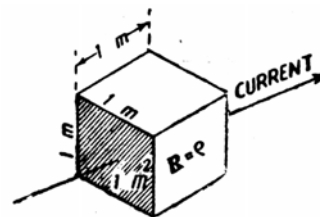
**fig. 1.5**

1.10. Resistors in series

When two or more resistances are connected in such a way that they form a train of resistances as shown in below fig1.6. Then it is known as resistance connected in Series. Let three resistances R_1 , R_2 and R_3 are connected in series to a supply V . In series combination the sum of the Voltage drops across each resistor is equal to the applied voltage and the current flowing through all the resistances is same. According to these series laws.

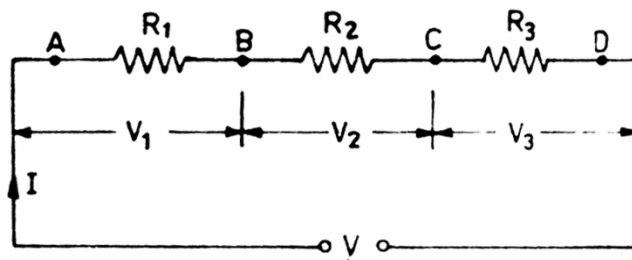

Fig. 1.6 : Resistance Connected in Series

$$\text{Applied voltage } V = V_1 + V_2 + V_3 \quad \dots\dots\dots 1$$

According to Ohms law

$$V = I R \quad \dots\dots\dots 2$$

$$V_1 = I R_1 \quad \dots\dots\dots 3$$

$$V_2 = I R_2 \quad \dots\dots\dots 4$$

$$V_3 = I R_3 \quad \dots\dots\dots 5$$

Substituting the equations 2, 3, 4, 5 in equation 1 we can get

$$I R = I R_1 + I R_2 + I R_3$$

$$\text{Thus total Resistance } R_t = R_1 + R_2 + R_3$$

Similarly - If N resistors are connected in series then the equation for total resistance

$$R_t = R_1 + R_2 + R_3 + \dots\dots\dots + R_n$$

If all the 'n' resistors are having same resistance then total resistance

$$R_t = R + R + R + \dots\dots\dots + R$$

$$= R (1 + 1 + 1 + \dots\dots\dots + 1) = nR$$

Thus the equation for total resistance when 'n' resistors are connected is

$$R_t = R_1 + R_2 + R_3 + \dots + R_n$$

The equation for total resistance when 'n' equal value resistors are connected is

$$R_t = nR \text{ (Where 'n' is the number of resistors)}$$

1.11 Resistors in Parallel

When two or more resistances are connected in such away that the voltage across each resistance is equal to the applied voltage then it is known as Resistance in parallel. Let R_1, R_2, R_3 be connected in parallel as shown in belowfig1.7. Then in parallel combination

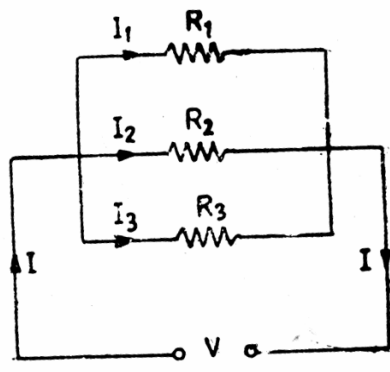

Fig. 1.7 : Resistance connected in Parallel

1. Voltage across all resistances is same
2. current in each resistor is different and is found by ohm's law.
3. The total current is the sum of the three separate branch currents.

According to these parallel laws.

Applied current $I = I_1 + I_2 + I_3$ 1

According to Ohm's law : $I_1 = V/R_1$ 2

$I_2 = V/R_2$ 3

$I_3 = V/R_3$ 4 and

$I = V/R$ 5

Substituting the equations 2, 3, 4, 5 in '1' we can get

$$V/R = V/R_1 + V/R_2 + V/R_3$$

$$V/R = V (1/R_1 + 1/R_2 + 1/R_3)$$