

1. STUDY OF PATTERN GENERATOR AND ITS USE

Aim :

To study the pattern generator

Operettas Required :

Pattern generator, T.V. Receiver, connecting wires.

Theory :

A pattern generator produces audio / video signals, direct and with the RF modulation, on the allocated T.V. Channel frequencies for alignment, testing and servicing of T.V. receivers. The output signals is designed to simple patterns.

1. Chess board pattern
2. Horizontal bars
3. Vertical bars
4. Chess board patter at one corner
5. Cross hatched
6. Dot pattern
7. Pure white pattern

Block Diagram :

The block diagram of the pattern generator given below.

The pattern generator contains two stable chains of multi vibrators, dividers and pulse shaping circuits, one below the line frequency to produce a series of horizontal bars and the other above 15,625 Hz to produce vertical bars. The signals are modified into short duration pulses which fed to the video section of the receiver along with the sync pulses train to produce fine lines on the screen.

Output from the multi vibrator produces square wave video signal at “m” times the horizontal frequency to provide vertical block and white bars. After every “m” cycles the horizontal blanking pulse triggers the multi vibrator for synchronizing the bar signal on each line. We can vary the number of bars by the front panels of pattern generator by changing its frequency.

In the same way, square wave pulses derived either from 50Hz mains or from the master oscillator are used to trigger another set of multi vibrators to generate square wave video signal that is “n” times the vertical frequency. When these are fed to the video amplifier they produce horizontal black and white bars. The switching rate of the multi vibrator can be controlled by a potentiometer i.e., on the front panel. It control the number of black and white horizontal bars. The sync and blanking pulses are added to these signals prior to modulation.

A master oscillator is used to generate blanking and gating pulses and generation. The composite sync. Signal is given to the pattern video signal and sync adder. The output of the vertical and horizontal bar generators goes to cross hatch and chequer board pattern generator. The pattern video signal is given to the adder. From this adder the signal goes to the VHF modulator.

Amplitude modulation takes place over the carrier frequency output is available in high or low level from the output sockets. The master oscillator, sync, generator and blanking generator supply the blanking pulses getting pulses to the multi vibrators that generate the vertical and horizontal bar signals.

A. 1 KHz audio oscillator generate a signal which is frequency modulated over a carrier of 5.5 MHz. This serves the purpose of the frequency modulated audio signal for the testing of the audio sections. Its output is available over a separate socket marked as audio / sound signal. The combination of switches mH and nV, the multi vibrator generate different pattern.

Switch mH	Switch nV	Output pattern
OFF	OFF	Pure white raster
OFF	ON	Horizontal bars
ON	OFF	Vertical bars
ON	ON	Cross hatch

The horizontal bar pattern is used for checking vertical linearity. The vertical bar pattern is used for check horizontal linearity.

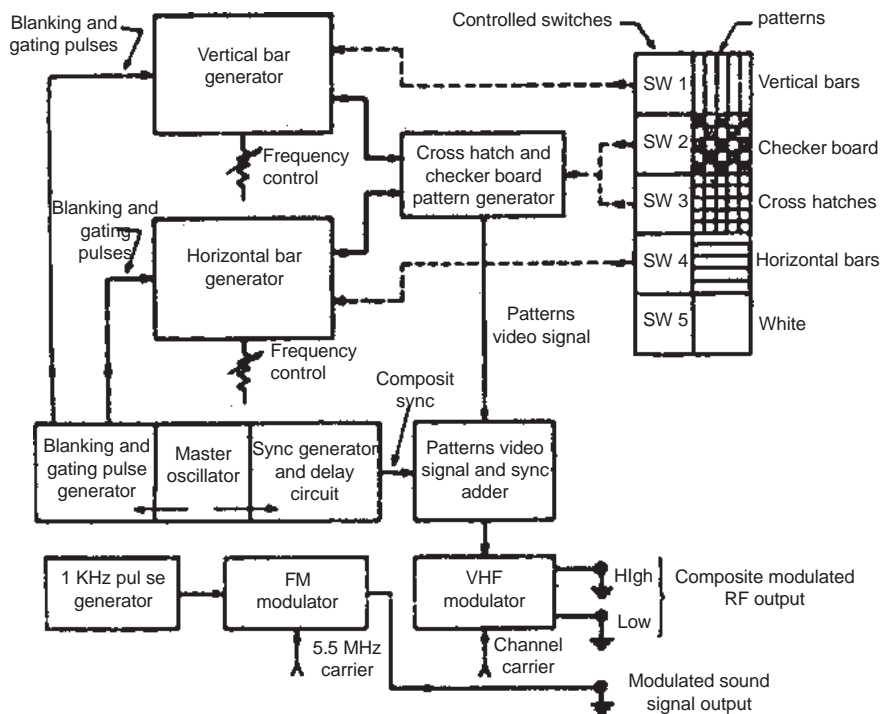

PATTERN GENERATOR

Fig 1.1

The cross hatch pattern is used for both linearity picture centering and aspect ratio. The dot pattern is suitable for checking and adjusting the static convergence of the picture in the centre of the screen with a low ambient brightness.

The white pattern, with no information is suitable for checking uniformity of brightness over the entire screen in the absence of hum.

Colour picture patterns are suitable for checking colour purity, proper colour reproduction and over all performance of the receiver. The test signals available with patterns generator are (1) RF signals (2) IF signals (3) Video signals.

Controls and specifications of pattern generator :

Controls :

1. Line frequency
2. Video (amplitude) output
3. Power ON/OFF switch
4. FM socket
5. RF socket
6. Controls to change vertical and horizontal bars.
7. Pattern selector switch.

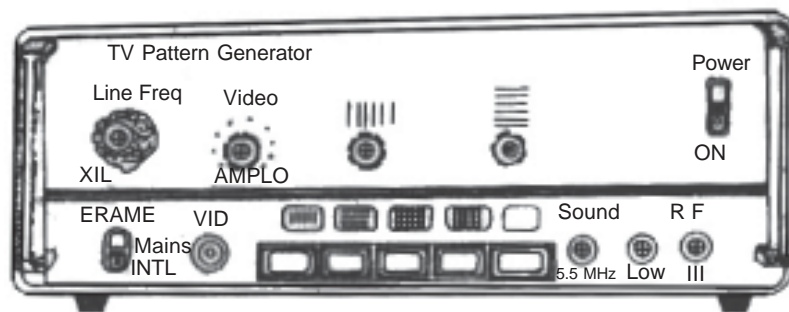

FRONT PANEL CONTROLS OF PATTERN GENERATOR

Fig 1.2

Specifications :

Power	:	230V/50Hz- 6W
FM Carrier	:	5.5 MHz
Internal signal	:	1KHz sine wave
Test signals	:	Vertical bars Horizontal bars Cross hatch Chequer board Circle - white Circle on black back - ground
RF output	:	100mV peak to peak

Applications :

1. Checking line and frame time bar linearity
2. Checking picture height and width
3. Video IF checking
4. Adjustments of sound IF stage and checking
5. AGC section checking
6. Trouble shooting video amplifier and using variable video output.

Procedure :

Connect the pattern generator to the T.V. receiver. Switch on the pattern generator. Set the T.V. receiver to the desired channel using band selector switch and channel selector switch\

Band I - 2 to 4 channels

Band III - 5 to 12 channels

Observe the seven patterns on T.V. receiver and make necessary adjustments in T.V. receiver.

Result :

The pattern generator is studied 7 patterns, video/audio patterns are observed and drawn.

Short Questions :

1. What is pattern generator
2. Give the applications of pattern generator
3. Give the specifications of pattern generator
4. Write Band I, II, III frequencies.

2. WOBBULOSCOPE

Aim :

Study of various controls of wobbuloscope, use for alignment of a T.V. receiver

Equipment Required :

Wobbuloscope, Balun, T.V. receiver and connecting wires.

Theory :

A wobbuloscope consists of a sweep generator, CRO and a marker generator, which can be tuned to frequencies corresponding to the vision carrier, associate of sound signal as well as the IF of the T.V. receiver

Alignment of a T.V. Receiver using wobbuloscope :

Using Wobbuloscope can test the tuner response, vedio I-F response, vedio response, sound IF response and over all frequency response using the following block diagram. The response of a amplifier or particular section visible on the screen of the CRO.

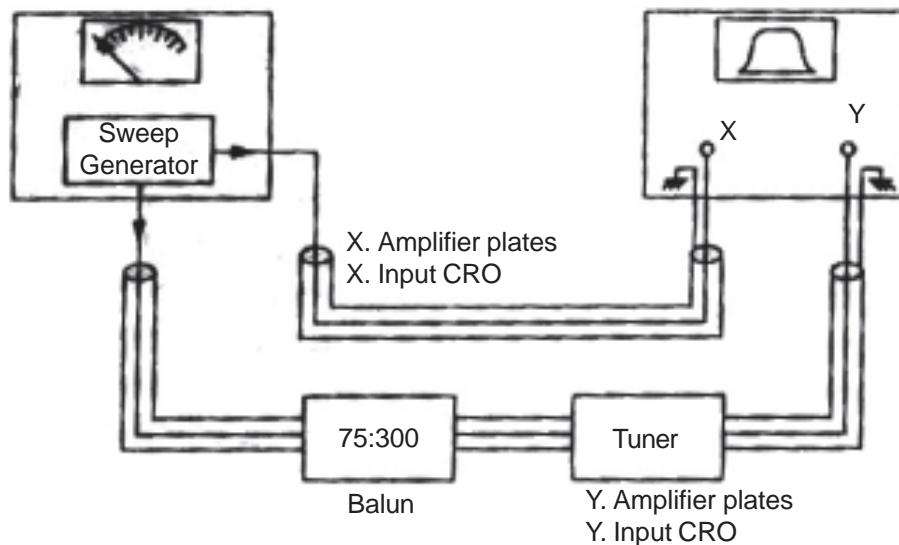

WOBBULOSCOPE

Fig 2.1

Two frequencies are generated from the sweep generator. One is at low frequency generally below 100 Hz called wobbulator frequency and another is corresponding to produce centre frequency is produce to IF frequency of the T.V. receiver 33.4 MHz, 38.9 MHz respectively.

The output signal from wobbuloscope given to the x-input of the CRO directly and another signal is given to balun (75:300) for impedance matching to the sections of the tuner of the receiver Y plates input to the CRO. The response curve is displayed on the CRO.

The connections are made as per the block diagram.

Controls :

1. Sweep frequency fine control
2. Sweep frequency course range control
3. ON/OFF switch
4. Marker frequency course range control
5. Marker frequency fine control
6. Sweep width control
7. Sweep width attenuator control
8. Rotating dial for marker frequency.
9. Y shift, X shift, Focus, Illumination, Time/Division Amplitude / Division of CRO controls.
10. RF output socket
11. Marker output terminals

Specifications :

- | | | |
|--|---|---------------------|
| 1. Power supply | : | 230V/50Hz |
| 2. Sweep width | : | 5MHz - 40 MHz |
| 3. Sweep frequency | : | 5MHz - 400 MHz |
| 4. Band width of oscilloscope | : | 20Hz - 1MHz |
| 5. Frequency of the time base generator of CRO | : | 20Hz to 50 KHz |
| 6. RF output voltages | : | 0.25V - 0.5V (rms). |

Results :

Marker frequency

- (i) AM - IF marker for Radio 455KHz
 - (ii) FM - IF - 10.7 MHz
 - (iii) Inter carrier frequency between SIF to VIF is 5.5 MHz
 - (iv) VIF - 38.9 MHz
SIF - 33.4 MHz
- and various controls of wobbuloscope is studied

Questions :

1. What is wobbuloscope
2. What are applications of wobbuloscope
3. What are the front panel controls of wobbuloscope
4. What are the specifications of wobbuloscope

3. OPERATING / SERVICING CONTROLS OF B/W T.V. RECEIVERS

Aim :

Study and familiarisation of operating and servicing controls of B/W T.V. receiver

Equipment Required :

T.V. Trainer board, operating, servicing controls of B/W. T.V. receiver.

Theory :

Operating controls of a B/W T.V. receiver :

1. ON/OFF Switch
2. Volume control
3. Tone control
4. Channel selector
5. Brightness control
6. Contrast control
7. Fine tuning control
8. Vertical hold control
9. Horizontal hold control

1. ON/OFF Switch :

This switch is meant to connect or disconnect the power supply mains to the receiver. It is located at a convenient position on the front panel and may be in the form of a toggle switch, a push-button switch, a piano key type or car ignition switch operated with a key. In most modern receivers, this switch is a part of the volume control.

2. Volume Control :

The level of sound output from the speaker can be controlled by the volume control which generally controls the audio voltage applied to the input of the preamplifier stage of the audio amplifier

3. Tone control :

This control is similar to the tone control in a radio receiver and it controls the proportion of high frequencies and low frequencies in the audio output, separate bass and treble controls are used in certain cases.

Actual control with control with concentric knobs is sometimes used to combine the volume controls.

4. Channel Controls :

This control is used in multichannel T.V. receiver. Its function is to select the coils and other components for the desired channel and connect these to the circuit in a proper manner

5. Brightness control :

This control adjusts the illumination or brilliance on the screen by varying the DC bias of the grid cathode circuit of the picture tube. The brightness control and the contrast controls are adjusted together to get a well defined clear picture on the screen.

6. Contrast Control :

This control is located in the video amplifier circuit and controls the amplitude of the video signal applied to the picture tube and works like the volume control for the audio signal. This control adjusts the sharpness on the screen and as to be operated in conjunction with the brightness control to get a proper contrast of black and white portions of the picture.

7. Fine tuning control :

This control varies slightly the frequency of the local oscillator or produce the correct IF in the frequency changer. It is in the form of either a variable capacitor a variable inductance or a potentiometer that adjusts the voltage across a varactor diode. This control is operated after selection of the desired channel, till a sharp and crisp picture with clear and undistorted sound is obtained.

8. Vertical Hold Control :

This control adjusts the frequency of the vertical oscillator to bring it close enough to 50Hz so that it synchronises with the sync signals from the transmitter. If the picture rolls up or down, the vertical hold control should be adjusted till the picture is steady.

9. Horizontal Hold Control :

This control adjusts the frequency of the horizontal oscillator adjusts the frequency of the horizontal oscillator to bring it in synchronisation with the horizontal sync. Signals. When the picture shifts horizontally or tears apart into diagonal segments, this control is adjusted to provide horizontal synchronization till the picture is again complete and steady.

Servicing Controls :

1. Vertical linearity control
2. Horizontal linearity control
3. Height control
4. Width control
5. AGC control
6. Picture position and centering control

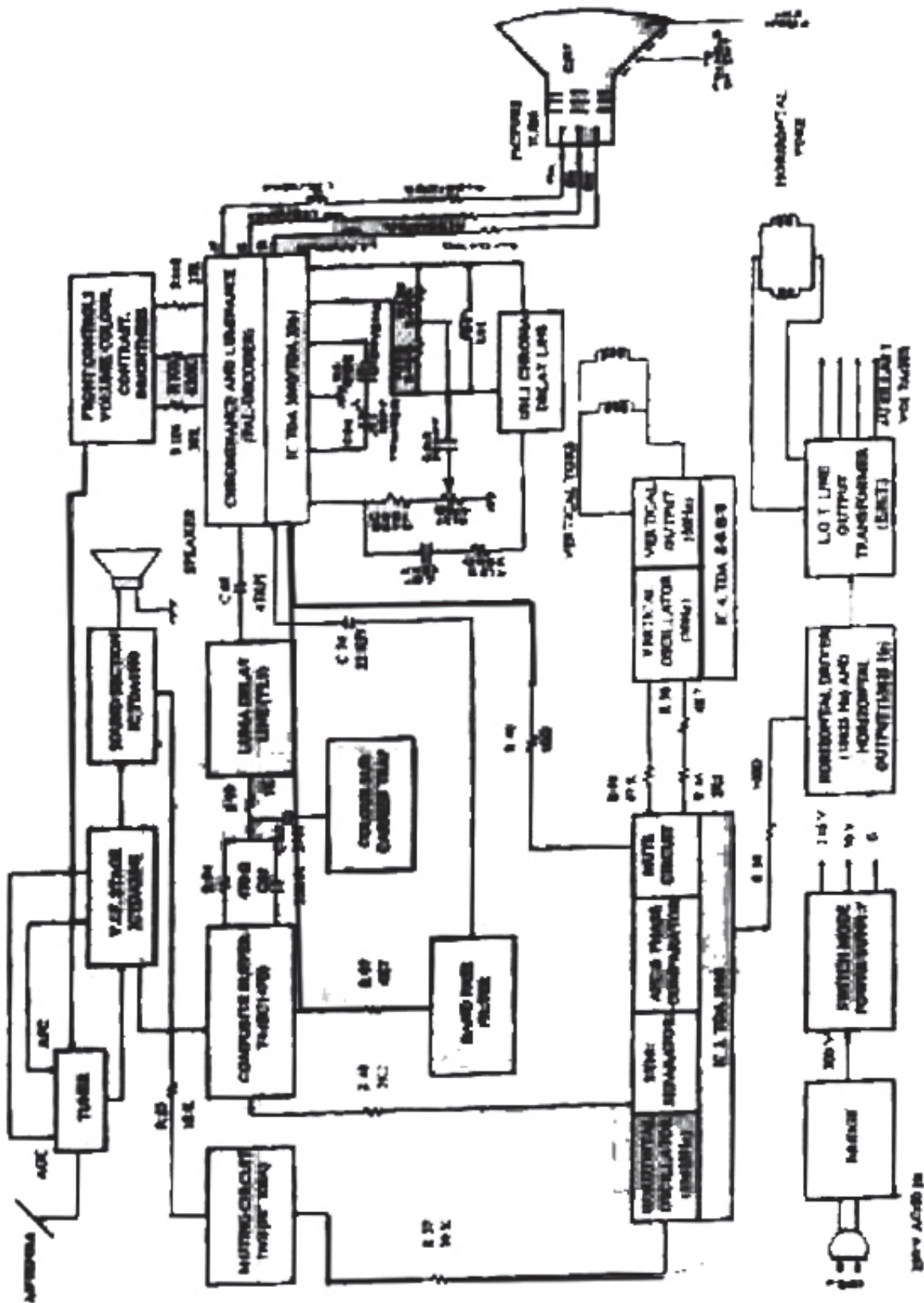

BLOCK DIAGRAM OF B/W T.V. RECEIVER

Fig 3.1

1. Vertical Linearity Control :

Vertical linearity control is in the vertical output stage, and adjusts the operating characteristics so as to make the scanning lines equally spaced from top to bottom for good linearity. If the picture is not uniform in the vertical direction, it is the result of vertical non-linearity which can be corrected by the vertical linearity control. This control either varies the cathode bias on the vertical amplifier or it controls the amount of feedback in the vertical circuit. The vertical linearity controls corrects overall vertical non-linearity. In certain cases, a separate linearity controls are provided for the top and bottom of the picture. Vertical linearity control affects the height of the picture. It is, therefore, necessary that the vertical linearity control and the height control should be adjusted simultaneously to obtain proper picture height control should be adjusted simultaneously to obtain proper picture height and linearity. Vertical linearity can be tested either with a text pattern from the T.V. transmitter or with the help of a pattern generator.

2. Horizontal linearity control :

Lack of horizontal linearity results in a non-uniform picture in the horizontal direction. If there are people in the picture, they appear too broad at the left or too thin at the right. For correcting horizontal non-linearity. Linearity coil is provided in many T.V. receivers. The core in the linearity coil can be adjusted to provide uniform picture. A pattern generator or test pattern can be adjusted to provide a uniform picture. A pattern generator or a test pattern can be used to checkup horizontal non linearity.

3. Height Control :

This control is located in the anode circuit of the vertical oscillator. It is a potentiometer that controls the supply voltage to the anode of the oscillator and the sweep voltage applied to the vertical deflection coil. This control is adjusted whenever the picture height is less than normal. Adjusting the vertical linearity control also affects the picture height which can be adjusted by the height control.

4. Width Control :

This is a control in the horizontal output stage. It is a variable resistor in the screen grid voltage for the horizontal output tube.

5. AGC Control :

The AGC Control is for the adjustment of the AGC Voltage applied to the RF and IF stages to control their gain. Different settings of the AGC control are required for strong signals and for weak signals, variation of the AGC control cuts off the picture and sound at one end or produces an over loaded picture at the other end. For proper adjustment of the AGC control, an over loaded picture is produced by tuning the control on one side and then backing off a little to produce a clear picture with good contrast. Different settings of the AGC control may be needed on different channels.

6. Picture position and centering magnets :

Picture tubes are fitted with a pair of deflection coils for horizontal and vertical deflection of the electron beam. The two deflection coils are arranged in a yoke housing fitted round the neck of the picture tube. The entire yoke can be turned round in its housing there by shifting the raster.

For positioning the picture, the yoke is made free to rotate by loosening a wing nut on the yoke coil. The entire yoke is then rotated till the raster is parallel to the edges of the screen. After this the yoke is pushed in fully and wing nut tightened.

For centering of the picture, the yoke coil is fitted with two magnetic discs or rings which can either be rotated together or with respect to each other so that the beam can be moved horizontally, vertically or any other angle. The magnetic rings are first moved together to the best position of the picture on the screen is obtained. The magnetic rings are then rotated with respect to each other till the raster or the picture is properly centered.

While making service adjustments by means of controls at the rear of the T.V. receiver it is necessary to watch the raster picture carefully. This can be done placing a mirror of suitable size in front of the T.V. Screen. If it becomes necessary to make certain adjustments with a pattern generator, these should be finally checked up the test pattern transmitted by the T.V. station before the start of regular telecast.

Result :

Servicing controls, operating controls of B/W T.V. receiver are studied.

Questions :

- 1) Name the servicing controls.
- 2) Write the operating controls.
- 3) Write servicing controls of B/W T.V. receiver.
- 4) Write operating controls of B/W T.V. receiver.

4. TRACING OF DIFFERENT STAGES IN A B/W T.V. RECEIVER

Aim :

To familiarize different stages, transistors, IC's used in B/W. T.V and typical Voltages.

Equipment Used :

B/W T.V Kit and Digital Voltmeter.

Theory :

The B/W T.V. model can be divided in to two parts.

Part I :

B/W picture tube, housed in a cabinet. 21' picture tube quick start type used.

Part II :

Different modules comprising the sub sections are as follows :

1. Tuner section
2. Sound I.F. section
3. Vedio IF section
4. Vedio output section
5. Sync. separation and Horizontal Oscillator section
6. Horizontal output and EHT section
7. Vertical deflection section
8. Switched mode power supply.

Additional concepts :

Power ON/OFF, Switch, Fuse and Ground, Brightness, Contrast Volume, Controls

Procedure :

From the trainer circuit above 8 stages are identified circuit wise.

Questions :

- 1) Trace the Block Diagram of T.V. Trainer Circuit Wise.

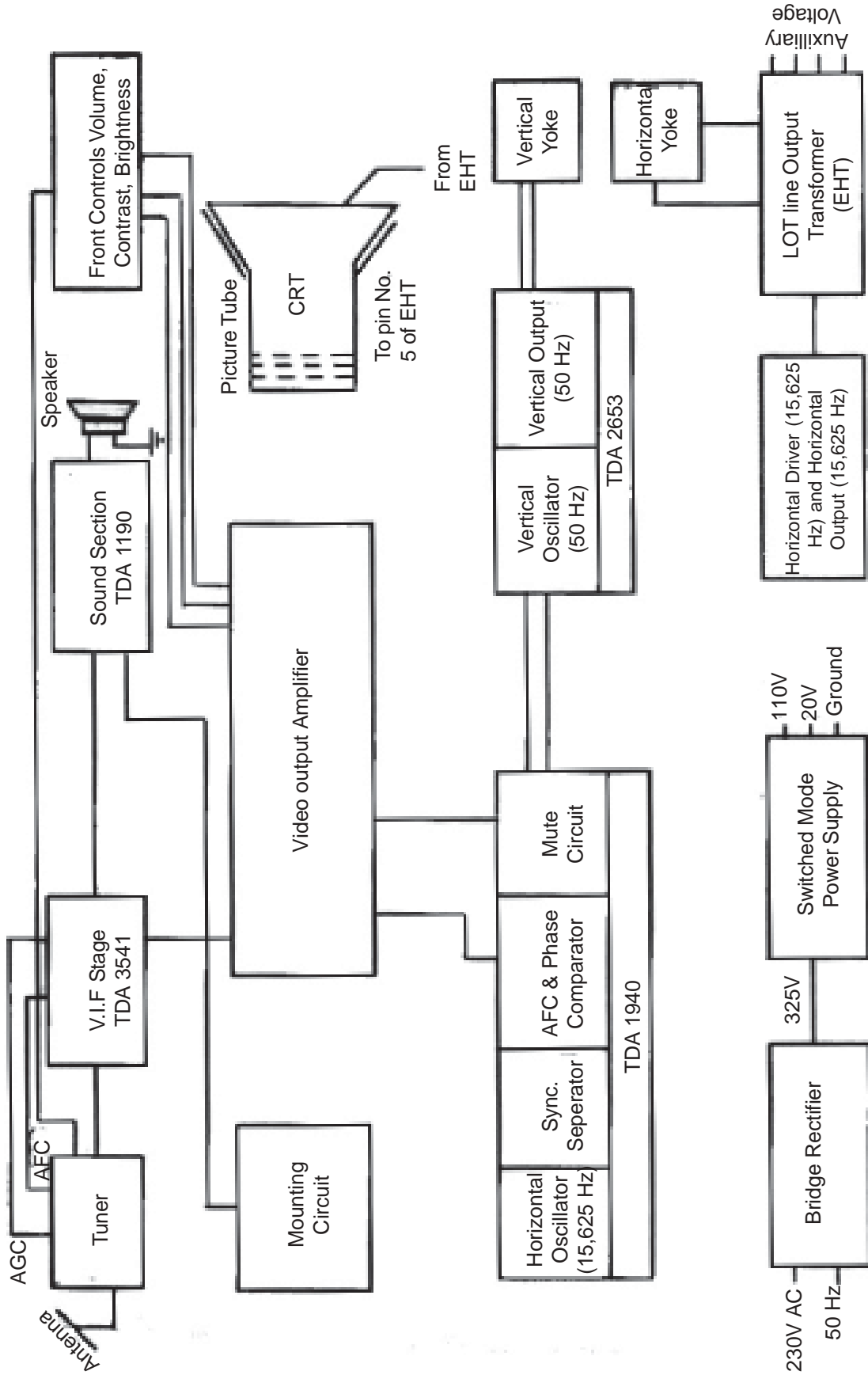

BLOCK DIAGRAM OF B/W T.V. TRAINER CIRCUIT

Fig 4.1

5. FAMILIARISATION OF DIFFERENT STAGES IN B/W T.V.

Aim :

Familiarisation of different stages in B/W T.V. receiver

Theory :

Detail description of the block diagram as follows:

Antenna :

The main function of antenna is to accept the electromagnetic waves coming from the television transmitter. Antenna receives these waves and converts them into RF signals which are given to the television receiver.

For better reception of RF signal, YAGI antenna is most commonly used in all television receivers in VHF / UHF range for its simple construction and low air resistance.

BALUN :

It is used for matching the impedance of balance 300W line to unbalanced 75W tuner input impedance. RF signal from antenna is given to the RF tuner through the balun transformer.

RF TUNER :

It is used for better picture and sound reception. The main functions of the tuner are :

1. It selects the desired station and rejects others.
2. It matches antenna with television receiver, because of this, ghost image can be removed.
3. It converts the RF signal into intermediate frequency by heterodyning it with local oscillator frequency.
4. It isolates the local oscillator signals from the antenna for preventing radiation it through the antenna.
5. It rejects the image frequency which causes the ghost image along with the picture. The RF tuner selects RF signals of desired (selected) channel, amplifier them and converts them into IF signals. The tuner consists of an RF amplifier, an oscillator and a mixer stage.

Local oscillator generates a constant frequency for desired channel. RF amplifier amplifies the RF signal achieved from antenna and mixer stage converts them into IF signal by heterodyning RF signal with the local oscillator frequency.

The IF carrier frequency present in IF signals for picture and sound are 38.9 MHz and 33.4 MHz respectively. Thus IF signal achieved from the tuner is fed to the IF amplifier.

IF PRE-AMPLIFIER :

It amplifies the IF signal. This stage of amplification is necessary because by the use of Saw Filter the gain of the receiver becomes less.

1) CA1190Z**SOUND SECTION :****IC-CA1190Z**

Pin No.	Voltages with colour Barsignal	Votages without any signal
1.	3.21 V	4.25 V
2.	3.21 V	4.60 V
3.	3.21 V	3.5 V
4.	0	0
5.	0	0
6.	2.49 V	2.68 V
7.	2.49 V	2.68 V
8.(Min. Volume)	3.1 V	-
(Max. Volume)	1.65 V	2.1 V
9.	9.74 V	9.74 V
10.	0.72 V	0.72 V
11.	10.04 V	10.04 V
12.	0	0
13.	0	0
14.	19.53 V	-21.2 V
15.	10.03 V	10.65 V
16.	8.08 V	10.5 V

2) Video IF section :**IC - TDA 3541**

Pin No.	Function	Typical DC Voltage (V)
1-16	Balanced IF input	4,4.6
2-15	De-coupling Capacitor for the DC feed back loop of the IF Amplifier	4,4
3	Adjusting pin for starting point of tuner AGC	1.2
4	Tuner AGC output	5.2
5	AFT Output	4
6	AFT ON?OFF Switch	6.8
7-10	AFT Circuit to obtain r/2 phase shift of the reference carrier	3.5, 3.5
8-9	Circuit for passive regeneration of the IF picture carrier	7.2, 7.2
11	Positive Power Supply	11.2
12	Video Output	4.0
13	Ground	0
14	IF AGC : VCR Switch	6.3

3) Sync. Separator & Horizontal Oscillator Section :

IC - TDA 1940 F

Pin No.	DC Voltage (V)	Pin No.	DC Voltage (V)
1	0	10	4.0
2	1.4	11	3.2
3	0.6	12	6.9
4	1.6	13	4.2
5	7.2	14	12
6	0	15	5.6
7	10	16	5.6
8	5.4	17	4.6
9	1.4	18	0.1

Vertical Deflection Section :

IC - TDA 2653 A

Pin No.	Function	Voltage (V)
1.	Vertical Oscillator (The oscillator frequency is determined by a potentiometer at Pin No. 1 and a capacitor at Pin B	7.5
2.	Sync input/blanking output (50Hz) (combination of sync input and blanking output)	1.2
3.	Saw tooth generator output via buffer stage to pin No.3 (It delivers the signal which is used for linearity control, and drive of the pre-amplifier)	3.8
4.	Pre-amplifier input (50 Hz)	1.7
5.	(+ve) positive supply of output stage (A diodes has to be connected between pin No. 5 and 9 for proper operation of the flyback generator)	
6.	Vertical output (50 Hz) for vertical deflection coil (Yoke)	13.5
7.	Flyback generator output (An electrolytic capacitor has to be connected between pin 7 and 5 to complete the fly back generator)	3.0
8.	Negative supply of output stage and small signal part	0
9.	(+ve) positive supply voltage (the supply at this pin is used to supply the flyback generator, voltage stabilizer, blanking pulse generator and buffer stage.	24.5
10.	Reference voltage of pre-amplifier	1.7
11.	Sawtooth capacitor (this saw tooth capacitor has been split to realize linearity control)	3.7
12.	50 Hz switching level	0.66
13.	Vertical Oscillator capacitor (the oscillator frequency is determined by a potentiometer at pin no. 1 and a capacitor at pin no. 13)	4.5

SAW-FILTER :

Here the saw filter is used in place of wave trap circuits. It passes only required frequencies and grounds unwanted adjacent channel frequencies.

VIDEO IF STAGE :

IC (TDA 3541) is used in video IF stage. This stage contains the function of video IF amplifier, video detector, video pre-amplifier, AFC and AGC circuits etc.

VIDEO IF AMPLIFIER:

It amplifies the IF signal to provide sufficient gain. AGC voltage is applied to all the separate IF amplifiers, except the last IF amplifier. From video IF amplifier the signal is applied to the video detector. Two or three stages are used in this amplifier stage.

VIDEO DETECTOR :

Signal obtained from video IF amplifier is injected into the video detector. AFC signal is also given to tuner section for automatic frequency control. Main function of the video detector section is to mix the picture IF (38.9 MHz) and sound IF(33.4 MHz) frequency to produce a new sound IF at 5.5 MHz. is fed to the sound section.

L-C filter or 5.5 MHz tank circuit is also used with video detector to remove the 5.5 MHz inter carrier sound signal from the video signal.

The video signal obtained from the video detector is then applied to the video amplifier. This amplifier is coupled to the video pre-amplifier as well as to the AGC sections.

SOUND SECTION :

The 5.5 MHz inter carrier signal from video detector stage is fed to the sound IF amplifier for proper amplification. Here sound signal is presided by a crystal tuned at 5.5 MHz.

SOUND IF AMPLIFIER :

The 5.5 MHz inter carrier signal from video detector is given to sound IF amplifier for stage proper amplification. Using a crystal filter the signal is further tuned.

F.M. DETECTOR :

5.5 MHz sound IF signal is amplified by one or two sound IF amplifier stages and then applied to detector stage. In this stage original sound signal is detected from the carrier.

AUDIO AMPLIFIER :

In this stage voltage amplification and power amplification is given to the audio signal and finally fed to the speaker.

VIDEO PRE-AMPLIFIER:

The video pre amplifier section amplifies the signal strength from 2V to 6V, so that it is able to drive video output stages.

HORIZONTAL SECTION :

IC is used in this section.

SYNC SEPARATOR :

It is an oscillator circuit taken from video amplifier circuit. In this circuit which separates two frequencies signals 50 Hz, 15,625 Hz with a automatic frequency control.

By using R,C circuit a high, low pass filter circuit is used to give horizontal and vertical stages respectively.

AUTOMATIC FREQUENCY CONTROL OR AFC CIRCUIT:

This stage if included in IC TDA 1940 F. This section compares the horizontal fly back pulse and incoming horizontal sync signal. The difference between these two appears as control voltage for controlling horizontal oscillator frequency.

HORIZONTAL OSCILLATOR :

This Oscillator generates 15,625Hz saw tooth horizontal frequency for horizontal deflection of electron beam inside the picture tube. Its frequency is controlled by the control voltage obtained from the AFC circuit.

HORIZONTAL DRIVER :

The signal obtained from horizontal oscillator weak signal is amplified to get required voltage, power gain and given to the driver transformer.

HORIZONTAL DRIVE TRANSFORMER :

It is used to match the impedance levels drive at high impedance to output at low impedance levels.

HORIZONTAL OUTPUT STAGE :

This stage consists of a transistor and EHT transformer power amplification is provided to the horizontal scanning frequency. The output given to horizontal deflection coil and EHT.

An auxiliary power supplies are used such as 25 V, 12.6 V, 13 V, 150 V supply for heater, high voltage is used to final anode of the picture tube. Horizontal flyback pulses are also obtained from EHT.

VERTICAL STAGE :

In this blocks are vertical oscillator, vertical driver and vertical output.

VERTICAL OSCILLATOR :

The output signals which are coming from integrator circuit with 50 Hz line frequency signals given to a saw tooth filter and given to vertical driver.

VERTICAL DRIVER :

This stage provides voltage amplification to the vertical signal, obtained from the oscillator.

VERTICAL OUTPUT :

This stage gives sufficient power amplification to the vertical line signal and the output is given to vertical deflection coils.

Tabulation of IC's pin wise voltages

IC No. :

Each IC pin voltages are to be taken

Pin No.	Pin Voltage

Result :

IC's and transistor observed at various points measured voltages at various stages.

Questions :

1. What is the function of an antenna.
2. What are the functions of RF Tuner
3. Which signals are transmitted from T.V. Station.
4. What are the front panel controls of the B/W T.V. receiver.
5. Can we receive colour signals in B/W T.V.
6. Write importance of the SMPS
7. Write IC no's used in different stages in T.V.
8. Expand LOT? Where it is used.

6. TRACING OF DIFFERENT STAGES IN COLOUR T.V.

Aim :

To identify different stages in colour T.V. receiver, tracing of transistor, IC's and stage identification.

Equipment Required :

1. Colour T.V. Trainer Kit
2. Digital Voltmeter
3. Cathode Ray Oscilloscope

Theory :

The blocks of colour T.V. receiver as follows.

1. Antenna
2. RF Tuner
3. Video IF amplifier
4. Video detector
5. Synchronous Video IF detection
6. Sound detection and processing
7. Luminance Channel
8. Comb Filter
9. Chroma Decoder Section
10. Automatic Colour Control
11. Colour Killer Circuit
12. PAL Dematrix
13. Synchronous detection
14. Video drive section
15. Gray scale tracking
16. Deflection system
17. SMPS power supply

Results :

Stages IC's Transistor wise are identified

Questions :

1. Identified the different stages in Colour T.V. receiver.

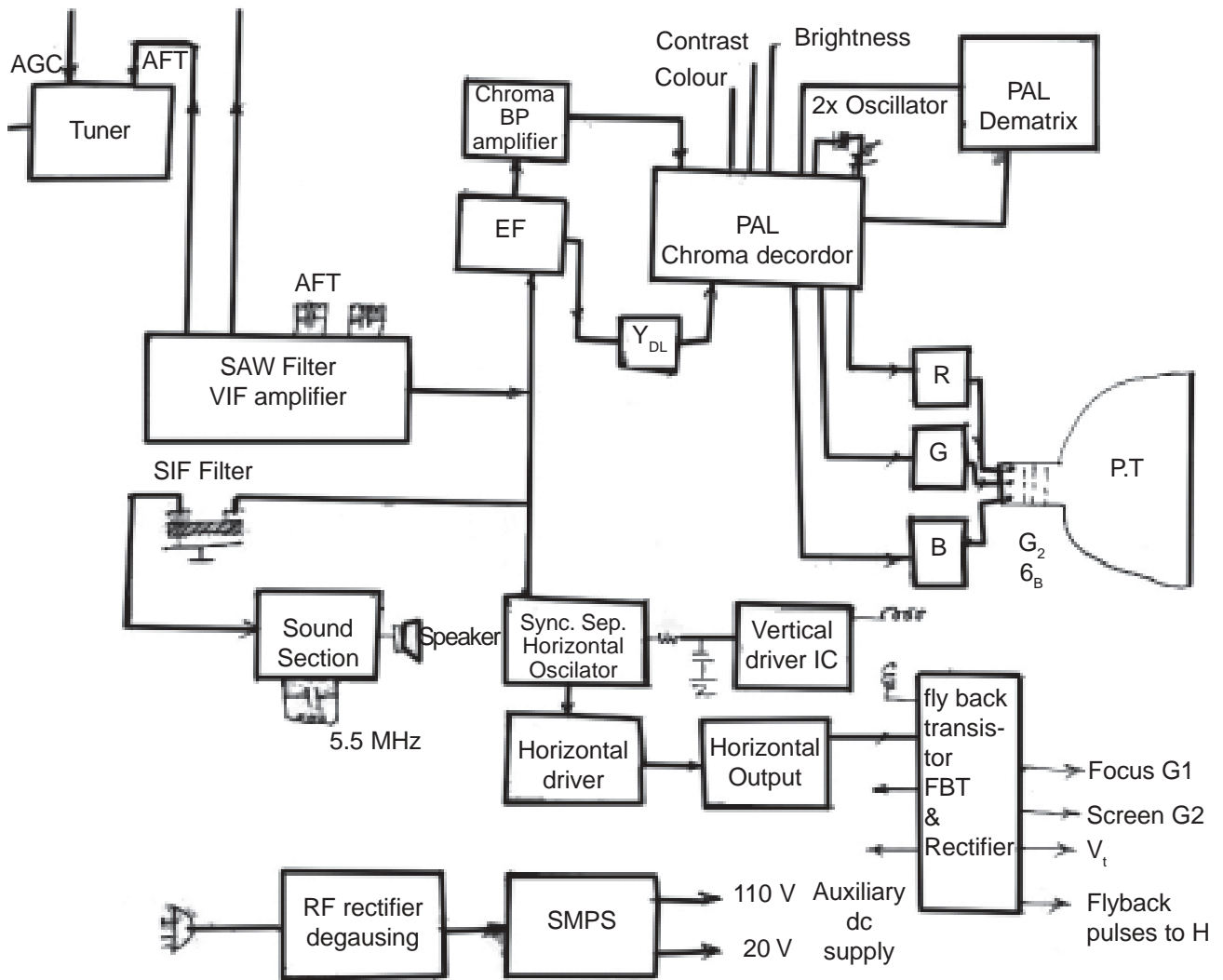

BLOCK DIAGRAM OF A COLOUR T.V. RECEIVER

Fig 6.1

7. FAMILIARISATION OF STAGES IN COLOUR T.V. RECEIVER

Aim :

Familiarisation different stages in Colour T.V. receiver, IC's used in various stages.

Equipment used :

1. Colour T.V. Trainer Kit
2. Digital Voltmeter
3. Cathode Ray oscilloscope

Theory :

Antenna :

The main function of an antenna is to accept the electro magnetic waves coming from the T.V. transmitter. Antenna receives these waves and converts them into RF signals. Which are given to the T.V. Transmitter. For better reception of RF signal, Yaagi Uda antenna is most commonly used to in all T.V. receivers in VHF/UHF range for its simple construction and low air resistance.

Balun :

It is used for matching the impedance balanced 300W to unbalanced 75W tuner input impedance. R.F. signal from antenna is given to the RF tuner through the balun transformer.

RF Tuner :

It is used for better picture and sound reception. The main functions of tuner are

1. Selection of desired channel frequencies and rejects others.
2. It matches antenna with T.V. receiver, because of the ghost image can be removed.
3. It converts the R.F. signal into IF signal by heterodyne with local oscillator frequency.
4. It isolates the local oscillator signals from the antenna for preventing radiation of it through the antenna.
5. It rejects the image frequency which causes the ghost image along with the picture. The RF tuner selects RF signals of desired channel amplifiers then is to IF signals. The tuner consists of an RF amplifier, an oscillator and a mixer stage.

Local oscillator generates a constant frequency for desired channel, RF amplifier amplifies the RF signal achieved from antenna and mixer stage converts them into IF signal by heterodyne RF signal from the local oscillator frequency. The IF carrier frequency present in IF signals for picture and sound are 38.9 MHz 33.4 MHz respectively. Thus IF signal achieved from the tuner is fed to the IF amplifier.

IF Pre-Amplifier :

It amplifies the IF signal. This stage of amplification is necessary because by the used of saw filter the gain of the receiver becomes less.

SAW - FILTER :

The saw filter used in place of wave trap circuits. It passes only required frequencies and grounds unwanted adjacent channel frequencies.

VIDEO IF STAGE :

By using an IC this stage is desired. This stage consists of video amplifier, AFC and AGC circuits etc.,

VIDEO IF AMPLIFIER :

This stage amplifies IF signal and provides sufficient gain. AGC voltage is applied to all the separate IF amplifier except the last IF amplifier. From video amplifier the signal is applied to the video detector.

VIDEO DETECTOR :

Signal obtained from video IF amplifier is injected to the video detector. In video detector the signal is demodulated giving back the Y-signal and the colour side band along with various synchronising pulses and the colour burst signal. AFC signal is also given to tuner section for automatic frequency control.

The video detector is to mix both VIF, SIF to produce a new IF sound IF signal at 5.5 MHz and fed to the sound section.

5.5 MHz tank (LC) circuit is also used with video detector to remove the 5.5 MHz inter carrier sound signal from the video signal.

From video detector video signal is obtained given to video amplifier input. This stage is coupled to video preamplifier and AGC sections.

Sound Section :**SOUND IF AMPLIFIER :**

The 5.5 MHz inter carrier signal from video detector stage is fed to the sound IF amplifier for amplification.

FM Detector :

5.5 MHz sound signal is amplified by SIF stage given to detector stage. The original sound signal is detected from the carrier.

Audio Amplifier :

In this stage voltage amplification is given to the audio signal and finally fed to the speaker.

Video Pre-Amplifier :

The output of Video amplifier the video signal is given to video pre amplifier. This signal consists of the 1) Luminance / Y Signal 2) The colour sub carrier containing red, blue colour difference signals 3) The horizontal and vertical sync pulses 4) The colour burst signal.

The video pre amplifier amplifies the signal strength from 2V to 6V, so that it is able to drive video output stages. In this stage the division of chrominance and luminance takes place.

From video pre amplifier video signal coupled to chroma band pass amplifiers through chroma filter circuit, sync separation and delay time circuit.

Delay time :

From video pre amplifier, Y signal passes through a delay time to amplifier stage. The delay line delays the Y signal by 0.8 milliseconds. The delay speed of the signal through the delay time is a special coil with very high value of inductance and distributed capacitance so that the delay speed of the signal through the delay line is greatly reduced.

Chroma section :

The output of video pre amplifier the composite colour video signal is coupled to the chroma band pass filter at 4.43 MHz and two stages of chroma amplifier.

The chroma filter separates the modulated chroma sub carrier signal and the colour burst from incoming composite video signals.

The separated chroma signals are amplified by the first chroma amplifier which is gain controlled by the voltage developed by the automatic colour control amplifier.

Colour Burst Circuit :

The colour burst circuit consists of the burst pre amplifier, pre amplifier pulse shaper and the gated burst amplifier.

Burst pre amplifier :

The chroma input signal from the chroma amplifier gets amplified in this stage.

Gated Burst Amplifier :

In this stage the gated horizontal flyback pulses are applied to this stage through a pulse shaping circuit.

Pulse Shaper :

The pulse shaper receives a positive pulse from horizontal output section. The conduction of gated burst amplifier depends on the gating pulses derived from pulse shapes. Burst signals are applied to Automatic Chroma Colour control circuit and phase discriminator.

Reference Oscillator :

The U and V signals are separately produced at the transmitting and by double balanced suppressed carrier modulator.

Automatic Colour Control (ACC) Circuit : In this stage colour is controlled automatically.

Burst Phase Discriminator :

This stage works by comparing the phase of wave from produced by the reference oscillator with the burst pulses obtained from the burst amplifier.

Colour Killer Circuit :

In this stage the colour killer is to be cut off the second chroma band pass amplifier when black and white program is obtained by a colour T.V. Circuit.

Sync Separator :

From the emitter of video pre amplifier, composite colour video signal is fed to the sync separator, horizontal, vertical sync signals are separated by the use of suitable low, high pass filter circuits. This stage also amplifies the signals.

Automatic Frequency Control/AFC Circuit : In this stage horizontal flyback pulses and horizontal sync signals are separated.

Horizontal Oscillator :

This stage generates 15, 625Hz saw tooth horizontal line frequency for horizontal deflection of electron beam inside the picture tube.

Horizontal Driver :

The signal coming from horizontal oscillator is amplified.

Horizontal Driver Transformer :

In this provides impedance matching.

Horizontal Output Stage :

This stage consists of a Transistor and an EHT Transformer amplification is provided in this stage.

Vertical Stage :

This is an IC version consists of vertical oscillator, vertical driver, vertical output.

Vertical oscillator :

Vertical line frequency 50Hz coming from low pass filter and deflected electron beam vertically in the picture tube.

Vertical Driver :

It provides voltage amplification to vertical signal.

Vertical output :

The vertical output is given to vertical deflection coil.

Power Supply :

A SMPS power supply is used to get 110V, 20V dc power

Tabulation :

S.No.	Type of stage	Transistors	IC's
1.	Tuner	BC 147, BC 157	CW 2225
2.	VIF (Video)	BC 959, BC 147	TDA 3541
3.	SIF (Sound)	-	IC TDA 1190/CA 1190z TDA 613
4.	Horizontal Output, Horizontal Oscillator sync separator	BD115, BC 157 BC 147	TDA 613, IC 3 TDA 1940F
5.	Vertical	BC 147(2)	IC4 TDA 2653A
6.	CD/VDA	BC 147	TDA 3560 / TDA 3561
7.	EHT	BU208 D	-
8.	SMPS	BU 536	IC 6 TA 4600A/4601

Typical Voltages

S.No.	Test Point	Voltages VPP (Volts)	Section on T.V.

Results :

IC's, transistors observed at various stages, voltages are observed at various points.

Questions :

1. What is balun
2. What are the operating controls of colour T.V. receivers
3. Can we receive B/W programs on colour T.V. explain the reason
4. Name the primary colours
5. Name the elements in Yaagi Uda antenna
6. Write SIF, VIF frequencies
7. What are the functions of tuner
8. What are the advantages SMPS.

8. MEASUREMENTS OF PICTURE TUBE VOLTAGES

Aim :

Measurement of B/W (Monochrome) picture tube voltages and adjustments.

Equipment Required :

A B/W T.V. receiver analogue and digital multimeters with high voltage facility work bench.

Theory :

The commonly used modern T.V. receivers picture tubes are 310 CIP4 (12"), 470CIP4 (19"), 500 CIP4(20"), 590 CIP4" (23"), 610 CIP4(24").

The 19" and 20" picture tubes have the same electrical characteristics. The 20" and 24" picture tubes have a more rectangular screen format and hence are more commonly used.

All these tubes use electro static focusing and electro magnetic deflection. The screen employs P4 phosphor and is aluminized. The data of above picture tubes as follows B/W picture tube voltage 500CIP4 (20"). The picture tube consists of cathode, control grid and final anode.

Pin No.	Function	Typical Voltage
1 and 8	Heater connected across 1 and 8	6.3 V a.c.
7	Cathode	75 V dc
2 and 6 (Internally shorted)	Control grid	-Ve to 40V dc
3	Screen grid	160V. dc
4	Focusing grid	0V
5	Ground	0V
6	No connections	0V

The picture tube extremely dangerous because it is a large evacuated glass bulb. A crack or puncture results is a violent in rush of air called an implosion, but the kinetic energy of the broken glass causes a subsequent explosion.

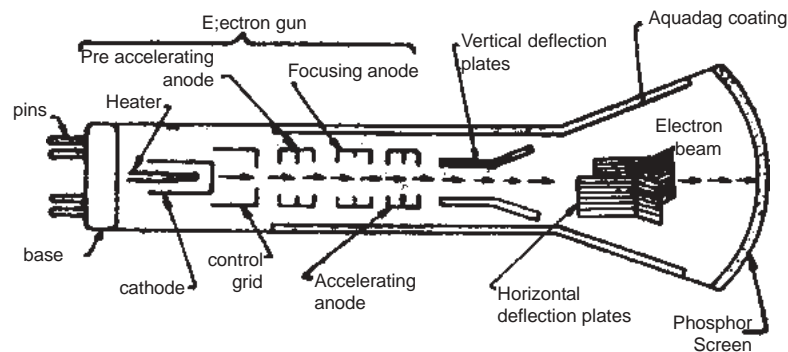

MONOCHROME PICTURE TUBE

Fig 8.1

You should always wear eye protection, such as goggles or a face shield when handling a picture tube. Also wear heavy gloves that provides a secure grip never handle picture tube by its neck.

High voltage precautions :

Always discharge the picture tube before removing it. To do this, connect a clip lead between the chassis ground and the metal shank of a plastic handled screw driver. Then holding the screw driver by its plastic handle the alter button under the rubber cap of the high voltage connector.

You will hear a snap when the tube is discharged.

Monochrome Picture Tube Data

Type	310CIP4 (12'')	500 CIP4 (20'')	610 CIP4 (24'')
Deflection angle	1100	1140	1100
Filament voltages	12V	6.3V	6.3V
Heater current	75mA	300mA	300mA
Accelerating anode voltage	10KV	16KV	18KV
Focusing anode voltage	0-400V	0-400V	0-400V
Cut off voltage	-33 to -77V	-41 to 99V	-41 to -99V
Length of the picture tube	240mm	311mm	362mm
Screen Size	312mm x 276mm x 224mm	505mm x 428mm x 344mm	613mm x 496mm x 392mm

Result :

B/W picture tube pin voltage are measured and tabulated.

Questions :

- 1) Define aspect ratio
- 2) Identify the parts of picture tube
- 3) What is the input signal to picture tube
- 4) Name the different sizes of the picture tubes
- 5) List the different voltages of the picture tube
- 6) Write picture tube precautions.

8. MEASUREMENTS OF PICTURE TUBE VOLTAGES

Aim :

Measurement of B/W (Monochrome) picture tube voltages and adjustments.

Equipment Required :

A B/W T.V. receiver analogue and digital multimeters with high voltage facility work bench.

Theory :

The commonly used modern T.V. receivers picture tubes are 310 CIP4 (12"), 470CIP4 (19"), 500 CIP4(20"), 590 CIP4" (23"), 610 CIP4(24").

The 19" and 20" picture tubes have the same electrical characteristics. The 20" and 24" picture tubes have a more rectangular screen format and hence are more commonly used.

All these tubes use electro static focusing and electro magnetic deflection. The screen employs P4 phosphor and is aluminized. The data of above picture tubes as follows B/W picture tube voltage 500CIP4 (20"). The picture tube consists of cathode, control grid and final anode.

Pin No.	Function	Typical Voltage
1 and 8	Heater connected across 1 and 8	6.3 V a.c.
7	Cathode	75 V dc
2 and 6 (Internally shorted)	Control grid	-Ve to 40V dc
3	Screen grid	160V. dc
4	Focusing grid	0V
5	Ground	0V
6	No connections	0V

The picture tube extremely dangerous because it is a large evacuated glass bulb. A crack or puncture results is a violent in rush of air called an implosion, but the kinetic energy of the broken glass causes a subsequent explosion.

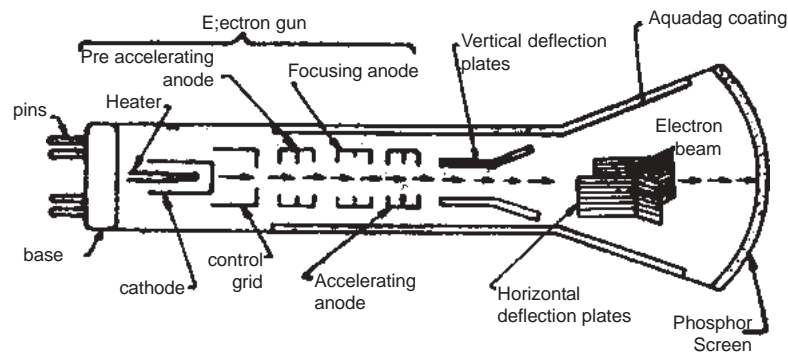

MONOCHROME PICTURE TUBE

Fig 8.1

You should always wear eye protection, such as goggles or a face shield when handling a picture tube. Also wear heavy gloves that provides a secure grip never handle picture tube by its neck.

High voltage precautions :

Always discharge the picture tube before removing it. To do this, connect a clip lead between the chassis ground and the metal shank of a plastic handled screw driver. Then holding the screw driver by its plastic handle the alter button under the rubber cap of the high voltage connector.

You will hear a snap when the tube is discharged.

Monochrome Picture Tube Data

Type	310CIP4 (12'')	500 CIP4 (20'')	610 CIP4 (24'')
Deflection angle	1100	1140	1100
Filament voltages	12V	6.3V	6.3V
Heater current	75mA	300mA	300mA
Accelerating anode voltage	10KV	16KV	18KV
Focusing anode voltage	0-400V	0-400V	0-400V
Cut off voltage	-33 to -77V	-41 to 99V	-41 to -99V
Length of the picture tube	240mm	311mm	362mm
Screen Size	312mm x 276mm x 224mm	505mm x 428mm x 344mm	613mm x 496mm x 392mm

Result :

B/W picture tube pin voltage are measured and tabulated.

Questions :

- 1) Define aspect ratio
- 2) Identify the parts of picture tube
- 3) What is the input signal to picture tube
- 4) Name the different sizes of the picture tubes
- 5) List the different voltages of the picture tube
- 6) Write picture tube precautions.

10. FRONT PANEL CONTROLS AND ADJUSTMENTS

Aim :

To study front panel controls of a T.V. receiver

Equipment Required :

A T.V. receiver B/W

Theory :

The operators controls have to be operated frequently for proper reproduction of picture and sound and are located in an easily accessible position, generally the front panel of the T.V. receiver. The operators controls are operated by knobs to make the operation smooth and easy but the service controls are generally adjusted a screw driver or some other tool designed for this purpose. The operator controls are operated by the viewers to obtain the picture quality to suit their tasks. The front panel controls as follows

- 1) ON/OFF Switch
- 2) Volume Control
- 3) Tone Control
- 4) Channel Selector
- 5) Brightness Control
- 6) Contrast Control
- 7) Fine tuning Control
- 8) Vertical hold Control
- 9) Horizontal hold Control

1. ON/OFF Switch :

This device is used to connect or disconnect the power supply mains to T.V. receiver. It is located at a convenient position on the front panel and may be in the form of toggle switch. In most modern receivers, this switch is a part of the volume control.

2. Volume Control :

The level of sound output from the speaker can be controlled by the volume control, which generally controls the audio voltage output.

3. Channel Selector :

This control is used in multi channel T.V. receivers. Its function is to select the coils and other components for the desired channel and connect these to the circuit in a proper manner.

4. Brightness Control :

This control adjusts the illumination on the screen by varying the dc bias of the grid cathode circuit of the picture tube. The brightness control and the control controls are adjusted together to get a well defined clear picture on the screen.

5. Contrast Control :

This control is located in the video amplifier circuit and controls the amplitude of the video signal applied to the picture tube and works like the volume control for the audio signal. This control adjusts the sharpness of the picture on the screen and has to be operated in conjunction with the brightness control to get a proper contrast of black and white portions of the picture.

6. Fine Tuning Control :

This control varies slightly the frequency of the local oscillator to produce the correct IF in the frequency changer. It is in the form of either a variable capacitor a variable inductor or a potentiometer that adjusts the voltage across a varactor diode. This control is operated, after selection of the desired channel, till a sharp and crisp picture with clear undistorted sound is obtained.

7. Vertical Hold Control :

This control adjusts the frequency of the vertical oscillator to bring it close enough to 50Hz so that it synchronises with the sync. Signals from the transmitter. If the picture rolls up and down the vertical hold control should be adjusted till the picture is steady.

8. Horizontal Hold Control :

This control adjusts the frequency of the horizontal oscillator to bring it in synchronisation with horizontal sync. Signals, when the picture shifts horizontally or tears apart into diagonal segments, this control is adjusted to provide horizontal synchronization till the picture is adjusted is again complete and steady.

Results :

Operating controls are operated to a B/W T.V. receiver.

Questions :

1) Write operating controls of a T.V. receiver.

11. T.V. PICTURE AND SOUND ADJUSTMENTS BY USING PATTERN GENERATOR

Aim :

Adjustments of Picture and sound by using pattern generator.

Equipment Required :

Pattern Generator, T.V. receiver, RF Card.

Theory :

Pattern generators provide video signals direct and with RF modulation on the standard T.V. channels so that it can be used for testing and alignment of T.V. receivers. The video signals is designed to produce simple geometric pattern like vertical bars, horizontal bars - cross hatch, grill, chess-board and gradation patterns. These patterns are convenient for alignment of raster geometry and its linearity, and also for the video amplifier adjustments. The RF Channel modulation with FM sound carrier facility along with it, makes it a useful T.V. signal source for servicing purposes.

If there is no raster and no sound available from the receiver, the power supply circuit that feeds the heaters of the valves and the B+, Vcc supplies need a check. Fuses in the supply leads may be checked. If the mains fuse is blown, a series lamp of a comparable, wattage may be temporarily included in the mains supply circuit to guard against frequent blowing of the fuse or damage to other components due to a short some where in the mains circuit.

The various test patterns to get clear alignment of a T.V. receiver as follows.

1. Circle on a black background is used to check framing, while black circle on white is more suitable for checking reflections.
2. Centre cross / Border lines provides checks for centering the T.V. screens, deflection linearity and pin cushion correction
3. White pattern 100% with colour burst are used to check colour purity and adjust the maximize beam current.
4. Dot pattern provides check for static convergence and focus. All dots should be pure white. Presence of colour dots indicate the need for adjustment of the convergence magnets and focusing if necessary.
5. Cross hatch / centre with 12 x 17 lines is used for checking and aligning dynamic and corner convergence in cushion correction of T.V. receiver.
6. Checker board pattern of 8 x 6 squares provides a visual standard for basic picture tube alignments like centering, focus, hand V deflection, linearity, framing, aspect ratio. Band width can be ganged by B/W transitions.

VIF Alignment :
Detector Coil :

The input circuit to the base VIF preamplifier is disconnected and a stair case or bar pattern. Modulate IF from the T.V. pattern generator is fed to the base through a 10nF capacitor. The synchronous detector coil is aligned for minimum block to white amplitude at the VIF sub system output monitored on a CRO. This corresponds to the optimum efficiency point of the detector.

AFT Coil :

Recommended 7.5V bias is applied to AGC terminal of the VIF module. AFT switch is closed and with no signal applied to the input, recommended 6.5V are applied to the AFT pin of the module. The switch is then opened, external IF - AGC bias is removed and 389 MHz VIF is fed to at the input. The AFT coil is adjusted to get the same recommended voltage 6.5V at the AFT pin.

Time VIF :

The tuner is then connected to the VIF module, recommended AGC bias of 7.5 V is applied and RF channel modulated with multi burst pattern fed to the tuner input. The tuner IF coil and the input circuit coil are aligned to obtain good band width as observed in the multi burst video output on the CRO.

RF AGC delay pot is adjusted for tuner AGC begins to rise to take over at an aerial input of 1mV and above.

Picture Geometry :

With the cross hatch pattern on the screen, the horizontal linearity coil is adjusted for best linearity and horizontal centering is set by position phase shift control associated with the synchronization IC. Width may be set if provided for in the circuit. The vertical height and linearity controls in the vertical drive circuit are adjusted for correct raster size and linearity.

SIF Coil :

The discriminator coil of sound IF is set for largest undistorted AF output.

SIF trap :

The sound IF series trap in the feed line to the chroma IC is adjusted for maximum SIF level. A 10:1 attenuator probe should be used to avoid loading due to CRO.

Result :

Good picture, clear sound is obtained / adjusted with pattern generator.

Questions :

- 1) Write the test patterns tapes.
- 2) Name the test patterns are rectified in video stages.
- 3) How clear sound is adjusted.

12. FAULTS IN B/W T.V. RECEIVER AND RECTIFICATION

Aim :

To study the fault in various stages of B/W T.V. receiver and rectification.

Equipment required :

A B/W T.V receiver, Multimeter tool kit box, soldering iron, paste and lead etc.,

Theory :

There are no thumb rules or cut and dry methods for the repairing of T.V. receivers except a through knowledge of the functions of the various stages and a careful observations of the indications provided by the picture tube screen and the loud speaker. However certain trouble shooting charts or tables based on major fault indications provided by the raster, picture and sound together with suspected stages and the likely defects sometimes prove helpful in quick location of the faulty stage or component as follows.

TROUBLE - SHOOTING CHART

Trouble symptoms	Suspected Stage	Likely defect
1. No. raster no sound no picture	Power supply	(i) Mains voltage not being applied either due to a blown off fuse or some defective lead (ii) Heater circuit open (iii) Defective dc rectifier circuit.
2. No raster, no picture but sound ok.	EHT circuit, line output stage picture tube, its bias and socket connections, video output circuit.	Defective EHT transformer (LOT) or line output transistor, EHT rectify or booster condenser, line oscillator, defective picture tube or improper voltages on its pins, defective brightness control picture tube socket, video amplifier transistor or IC
3. Raster and picture normal but no sound	Video amplifier	Sound IF, FM detector AF stage, loud speaker, sound IC.
4. Raster and sound normal but no	Video amplifier	Video amplifier transistor, Contrast control, or coupling capacitor, between video amplifier and picture tube cathode.

5. Raster normal but no picture, no sound	Antenna, feeder wire line, tuner, video, IF amplifier video detector, AGC.	Broken antenna or feeder line, tuner voltage defective video IF amplifier stage, defective detector diode, AGC adjustment.
6. No raster no picture only a bright horizontal line on the screen sound normal	Vertical sweep, vertical deflection coil	Defective vertical stage, open vertical deflection coil.
7. No raster, no picture but only a bright vertical line on screen sound	Horizontal deflection coil	Line deflection coils or circuit components between LOT and horizontal deflection coils, weak line output stage normal.
8. Raster and sound normal but picture height is less even with maximum position of height control	Vertical oscillator, vertical output or vertical deflection coil	Defective oscillator transistor reduced voltage, to vertical oscillator or output stage, defective vertical output transformer defective vertical deflection coil, effective VDRs.
9. Raster and sound normal but picture width is less.	Horizontal deflection stage, horizontal deflection coil.	Line oscillator stage, line output amplifier, defective booster diode, reduced HT voltage, defective horizontal deflection coil.
10. Picture rolling vertically, raster and sound normal	Vertical oscillator	Vertical oscillator stage, defective vertical hold vertical sync separator.
11. Picture torn, diagonal bars and slanting streaks	Horizontal oscillator, Horizontal sync., AFC	Horizontal oscillator stage oscillator coil adjustments, coil core defective, discriminator circuit power supply filter circuit
12. Picture unstable both in horizontal and vertical direction	Sync separator, AGC, signal section.	Sync separator IC, defective AGC stage, tuner or video amplifier gain adjustment.
13 (a) Vertical non-linearity	(a) Vertical oscillator or vertical output	(a) Vertical output transistor vertical linearity control.
(b) Horizontal non-linearity	(b) Horizontal deflection drive	(b) Line oscillator or line output stage, booster diode or booster capacitor, horizontal linearity coil.

14. Blooming in picture	EHT rectifier stage	Defective EHT rectifier.
15. Ghosts	Antenna	Antenna direction, not correct director or reflector missing.

Result :

In all stages various problems are studied with rectification measures.

Questions :

1) Study the various faults in the T.V. receiver.

13. FAULTS IN COLOUR T.V. RECEIVER

Aim :

Study and rectification of faults in various stages of colour T.V. receivers.

Equipment Required :

Colour T.V. Trainer Kit, Multi meter tool Kits.

Theory :

A colour T.V. receiver is basically a black and white receiver with some additional colour circuits. It will, therefore, develop all the trouble symptoms of a normal monochrome receiver plus trouble symptoms that are peculiar to the colour circuit alone. A number of stages like the RF tuner, video IF, video detector and video amplifier are common to both the monochrome and colour T.V. receivers. Any defect in these common circuits will effect the reproduction of the colour picture because the luminance. Signals as well as the chroma signals pass through these stages. A weak or completely washed out colour picture can result if the chroma signal is attenuated due to poor alignment of the RF tuner stages and the IF amplifier stages. It is therefore, necessary that before rectifying colour troubles it must be made sure that the receiver is able produce a good B/W picture of normal quality.

The first step in trouble shooting in the case of a colour T.V. receiver is the proper adjustment and setting of the operating controls. Many troubles in a colour T.V. are due to improper adjustment of these manual controls. It is to reduce these troubles to a minimum that some of these operating controls have been replace by an automatic controls.

The brightness and contrast controls should be adjusted to get the correct ratio of light and darkness on the screen. The fine tuning control should be adjusted for best display of colour because any improper, adjustment of this control can result in complete loss of colour. The two colour controls, namely the colour control and that the tint control, should be adjusted only after monochrome controls have been adjusted only after monochrome controls have been adjusted for optimum results. The operation of the colour control will only change the saturation of the picture colours but with not affect the hue or tint of the picture. any change in tint with adjustment of the colour control indicates defective or misaligned chroma band-pass amplifier. The tint control should be adjusted to give correct flesh colours. an overall green, red or blue picture indicates improper setting of the tint control.

If the trouble symptoms in a colour T.V. receiver still persist even after the operating controls and colour setup have been adjusted the fault could attributed to the colour circuits. These circuits include the chroma amplifier, the colour burst amplifier, the colour killer, the sub carrier oscillator colour circuits and the colour demodulator circuit. The troubles in the colour sections of the receiver can be located with help of the trouble shooting chart given below.

S.No.	Fault Symptoms	Possible Cause	Remedial Measures
1.	No Colour	1. Chroma amplifier 2. Sub-carrier oscillator 3. Colour Killer	Check chroma amplifier circuit and operation of colour killer and associated circuits
2.	Colour show on monochrome picture	1. RF stages 2. Colour killer stage	Check alignment of RF stage and also check colour killer and associated circuits.
3.	Weak colour	Chroma band pass amplifier	Adjust tuning of band pass amplifier transformer
4.	Drifting colours or colour bars.	No colour sync.	Adjust colour phase discriminator or burst amplifier
5.	One colour missing	1. Defective electron gun 2. Defective chroma demodulator	Test individual electron guns and also check the relevant chroma channel.
6.	In correct relative hues	Phase error in sub carrier oscillator	Adjust tint control and check sub carrier oscillator for a leaky capacitor.
7.	Abnormally intense colours	Automatic colour control (ACC) or defective colour control.	Check ACC circuit and replace defective colour control.

Result :

Colour T.V. kit is studied for various faulty and adjustments.

Questions :

- 1) What is colour burst signals
- 2) Explain colour killer circuit.
- 3) How do you identify fault in colour T.V. and write rectification methods.

14. SWITCHED MODE POWER SUPPLY (SMPS)

Aim :

To study SMPS and measurement of output voltages.

Equipment required :

A SMPS power supply, 100W bulb, a digital multimeter.

Theory :

The power supply which converts 300 V dc to 110V dc is known as switched mode power supply. Simply it denoted as SMPS

A switched mode power supply consists of the following blocks.

1. 230V ac. rectifier with filter circuit which gives 300V dc
2. Switching convertor and oscillator.
3. Feed back circuit
4. Error amplifier with voltage, sensing winding.
5. Switched mode transformer
6. Output dc voltages 110V, 20V.

(i) 230 V Rectifier with filter :

This is a full wave bridge rectifier circuit in which conducts D1, D3 first positive half cycle in the time period 0-p. As soon as a negative half cycle received by the diodes D1, D3 moves into reverse bias mode and hence there is no conduction in the period p-2p. The other diodes D2, D4 are moved in to forward bias mode conducts remaining half cycle p-2p period. There is a full wave conduction by the bridge rectifier. This operation repeats for remaining cycles operation.

The pulsating these positive half cycles if filtered by the an electrolytic capacitor, which give d.c. voltage. The d.c. voltage obtained here is $230 \sqrt{2} = 325V$

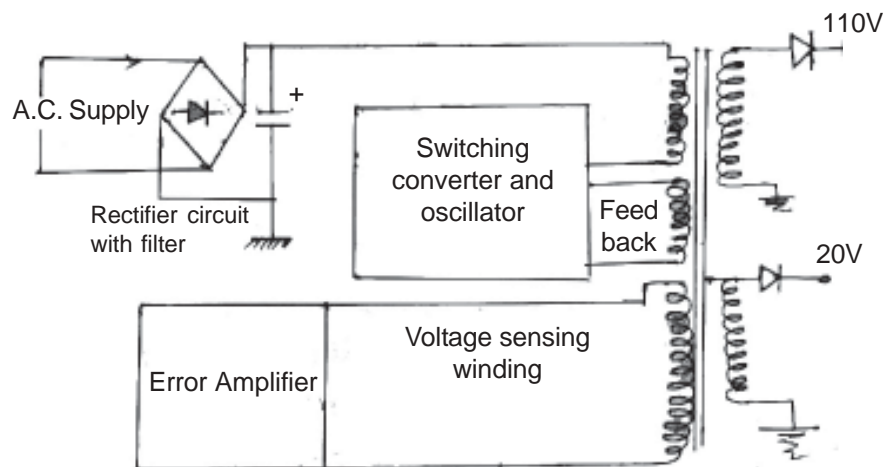

SWITCHED MODE POWER SUPPLY

Fig 14.1

(ii) Switching convertor and oscillator circuit :

The 325V dc. supply is given to collector of the switching transistor through a SMPS transformer. Through a bias network base of the transistor is given proper biasing with timing network. The timing circuit consists of ON, OFF times approximately 30 microseconds. The switching transistor converts 325V dc. Supply in to square wave given to SMPS transformer.

(iii) Feed back circuit :

This provides the positive feedback to the switching transistor to the base of the switching transistor. With ON, OFF times, which gives the square wave to a SMPS transformer.

(iv) Error amplifier with voltage sensing winding :

7,8 pins of transformer is said to be sensing winding. The voltage present on this pins is proportional to 1 mains supply. Any change in sensing winding changes the charging of capacitor. The output voltage is given by

$$V_{\text{output}} = \frac{V_{\text{in}} \times T_{\text{ON}}}{T_{\text{ON}} + T_{\text{OFF}}}$$

Where V_{in} = input voltage

T_{ON} = Switching transistor on time

T_{OFF} = Switching transistor off time

V_{o} = output voltage.

The sensing circuit consists of error amplifier, slow start circuit, slow rise circuit, short circuit protection and over voltage protection.

Slow start circuit :

This circuit basically a timing circuit in which the supply starts slowly.

Slow rise circuit :

This circuit helps to rise the supply gradually.

The secondary voltage coming from the SMPS transformer is square wave. By using a diode 110V, 20V volts dc. is obtained. The SMPS output voltage we can measure 110V, 20V dc.

Procedure :

Connect a 100W bulb at 100V and measure all voltages with multimeter.

Result :

SMPS block wise operation is studied and dc. output voltages, rectified voltages are measured with multimeter.

Questions :

- 1) Draw the block diagram of SMPS
- 2) Measure output voltages of SMPS
- 3) Study the SMPS circuit with block diagram measure various voltages.

15. FAULTS IN SMPS

Aim :

Identify the stages in SMPS, faults in SMPS and rectification procedure.

Equipment Required :

A SMPS circuit, 100Watts bulb, Multimeter, Tool Kit box.

Theory :

In SMPS circuit the general faults occurring in the circuit as follows.

- 1) Burning of fuse
- 2) Failure of switching transistor.
- 3) No 110V dc output
- 4) Output dc supply less than 110V.
- 5) The output dc. supply more than 110V.

1. Burning of fuse :

When the problem in the switching converting transistor, bridge rectifier and filtering capacitor, the fuse burns and when replaced new one.

2. Failure of switching converting transistor :

In SMPS circuit if any transistor is shorted identify the same replace it in the place. If any equivalent transistor is replaced in the failure this switching converting transistor failures i.e., under in short circuit. For precaution any measure in the bridge rectifier circuit on each diode a disc capacitor is shorted to protect short circuit protection. Check the all transistors, base, collector, emitter, resistors and diodes in the circuit.

3. No. 110V. dc output :

Check the mains power chard, bridge rectifier, switching convertor transistor, switching convertor transistor collector presents 325V dc. base is 2V dc or less than 2V and Also check proper grounding of emitter from SMPS transformer 10 pia check the supply voltage. If there is no 110V dc, check error amplifier transistor Q4, D13 (8.2V zener diode), R1 preset driver of 470W, R17 of 1.2KW, R18 of 1.8 KW, R of 1.2 KW, R20 of 1 KW, also check D11 of BA159, C11 of 470PF, C12 of 100mF, D12 of BA159, C14 of 470mF, C13 of 100PF.

4. Below 110V. dc :

If the fault in error amplifier transistor Q4 BC158 check base, collector and emitter and components connected. If any one of the above component is shorted below 110V dc. comes. Also check the Q1 BU536 base feed back network.

5. Above 110V dc :

If the fault in error amplifier transistor Q4 base, collector and emitter any one of the components are leakage or open high resistance ohms occurs.

Results :

Problem in SMPS and rectification procedure is studied.

Questions :

- 1) Write the faults in SMPS
- 2) What are the output voltages of SMPS
- 3) Study the faults in SMPS suggest rectification procedure

16. TUNERS

Aim :

Study different types of tuners

Equipment Required :

Mechanical tuner, electronic VHF, UHF tuners, multimeter, T.V.Kit and connecting wires.

Theory :

RF tuners may be single channel or multi channel VHF tuners cover bands I and III only, while UHF tuners covers the UHF range of bands IV and V. With increasing use of UHF bands, electronic tuners covering VHF/UHF bands are now more commonly in modern receivers.

VHF tuners generally employ mechanical coil switching for the 12 VHF bands in low cost versions. This can be done by turret type or wafer type switch arrangement for coil changing.

Electronic tuners :

In electronic tuning employ continuous varactor tuning in all bands. I/III/IV/V

The block diagram of tuner

The tuner consists of the following blocks

1. Balun Transformer
2. RF Amplifier
3. Channel selector
4. Mixer
5. Local oscillator

The composite video signals which are coming from T.V. transmitter receives the antenna.

1. Balun Transformer :

It is a device which matches impedance at open air impedance 300W to tuner impedance 75W and passes the composite video signal.

2. Channel selector :

The signals which are coming from antenna goes to channel selector. The composite video signal divides conversions channel VCF, SCF signal goes to RF amplifier input. For example in a 7th channel VCF = 189.25 MHz, SCF= 194.75 MHz.

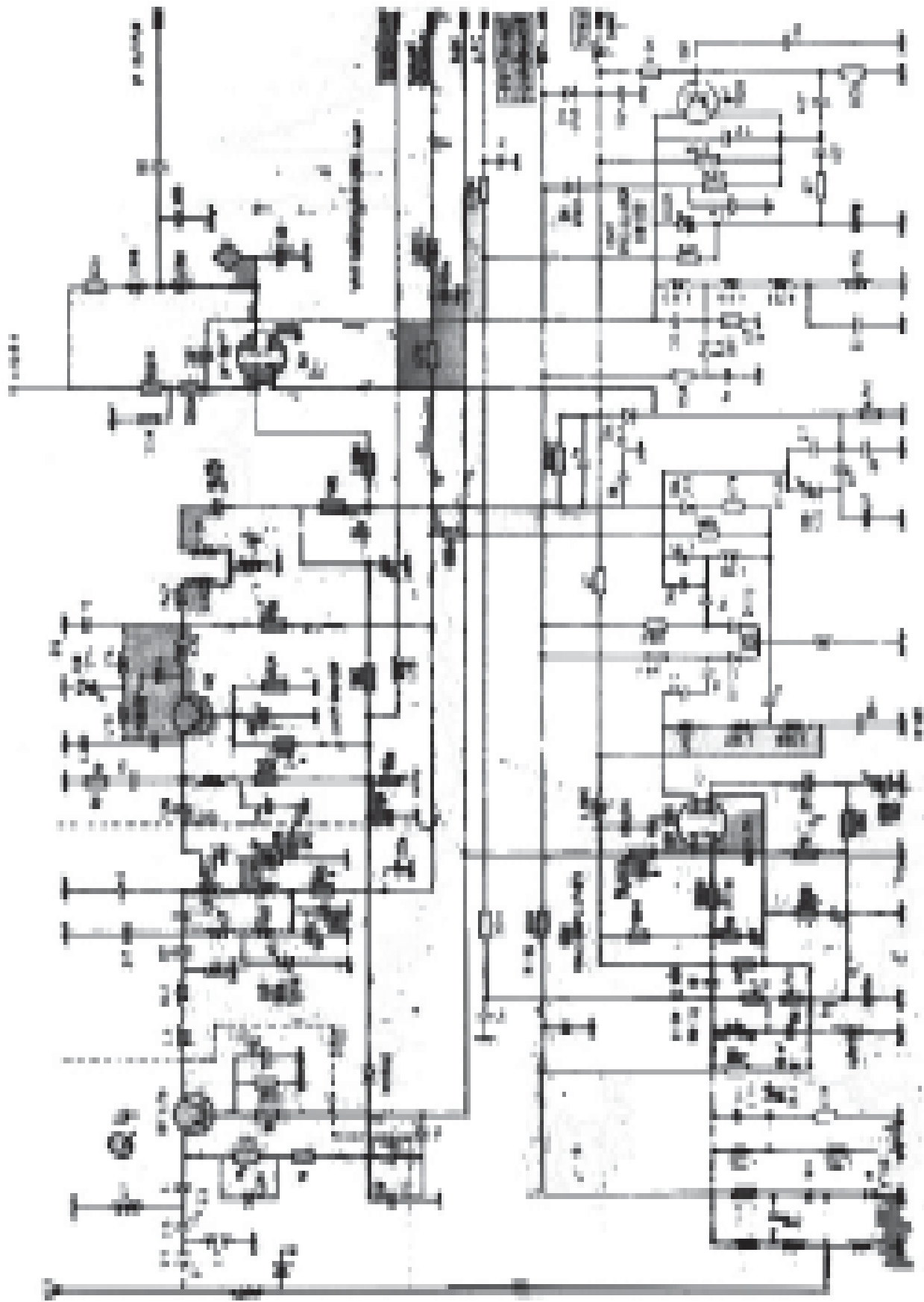

RF TUNER CIRCUIT

Fig 16.1

RF Amplifiers :

In this stage the RF signals are amplified by using NPN/MOSFET amplification is done. Transistor base is given positive voltage and given to AGC. The signals which are coming from positive voltage depends on gain of the stage.

Mixer :

In mixture stage RF signals are converted into IF signals. The RF signals are mixed with local oscillator frequency. VCF, SCF signals are heterodynes with oscillator frequency and produces VIF, SIF frequencies of 38.9 MHz, 33.5 MHz.

Local oscillator :

The local oscillator uses BF194B in a Colpitis oscillator with a capacitance between 2 PF and 33PF capacitors. Fine tuning is done by the varactor diode. The reverse bias of the diode and hence its junction capacitance is varied by 10 K potentiometer. The biasing tap is by passed to ground so that the capacitances of the leads of the panel mounted potentiometer do not affect tuning.

VHF/UHF tuner tunes tuning is done by diode tuning. The collector circuit of the mixer transistor is single tuned IF resonant circuit, at the low end of which the IF signal is capacitively coupled out of the tuner. An IF injection point is provided at the collector of the mixer for aligning this circuit together with the IF amplifier of the T.V. receiver.

The tuner requires transistor supply of +12V, a switching voltage of +12V, AGC voltages variable from +2.4 V to 7.5 V (Maximum AGC) and a tuning voltage variable from +0.5V - 28V. The tuner provides a gain of 28 dB to 40 dB and a noise figure of 6.5 dB.

Result :

VHF/UHF tuners are studied various voltages are measured.

Questions :

1) Draw the block diagram of tuner explain working.

T.V. Servicing Laboratory - II

Max Marks : 50

Periods : 5 periods per week

Total periods : 160

II Year PRACTICAL - I

1.	Study of pattern generator and its use	- 10
2.	Study of wobuloscope and its use for alignment of T.V. receiver	- 10
3.	Study of operating controls and servicing controls of B/W T.V. and typical voltages.	- 10
4.	Tracking of different stages in B/W T.V. Receiver	- 10
5.	Familiarisation of different stages with transistors, IC's used in B/W T.V., typical voltages.	- 10
6.	Tracing of different stages of colour T.V. receiver	- 10
7.	Familiarisation of different stages with transistors, IC's used in colour T.V. and typical voltages.	- 10
8.	Measurement of picture tube voltages of B/W colour T.V. and picture adjustment.	- 10
9.	Assemble erection of T.V. antenna	- 10
10.	Front panel controls and adjustments.	- 10
11.	T.V. picture, sound adjustments by using pattern generator	- 10
12.	Study the faults in various stages of B/W T.V. and rectification.	- 10
13.	Rectify the given faults in various stages of colour T.V.	- 10
14.	Study of SMPS and measurement of the output voltages.	- 10
15.	Identify the stages of SMPS, and mention the faults in SMPS and rectification of the faults.	- 10
16.	Study of different types of tuners.	- 10
	Total	- 160

IVC

SECOND YEAR

Electronics Engineering Technician

T.V. SERVICING LAB - II MANUAL

**STATE INSTITUTE OF VOCATIONAL EDUCATION
DIRECTOR OF INTERMEDIATE EDUCATION
GOVT. OF ANDHRA PRADESH**

Telugu Academy Publication : Vocational Course - fyc tec

**INTERMEDIATE
VOCATIONAL COURSE
SECOND YEAR**

**T.V. SERVICING LAB - II
MANUAL**

*FOR THE COURSE OF
ELECTRONICS
ENGINEERING TECHNICIAN*



**STATE INSTITUTE OF VOCATIONAL EDUCATION
DIRECTOR OF INTERMEDIATE EDUCATION
GOVT. OF ANDHRA PRADESH
2005**

**Intermediate Vocational Course, 2nd Year
T.V. SERVICING LAB - II
MANUAL
(For the Course of Electronics Engineering Technician)**

**Author : Sri. M. Shanmukha Chary
J.L in Electronics,
Govt. Jr. College, Malkajgiri, Secundrabad.**

**Complied by : Sri. M. Shanmukha Chary
J.L in Electronics,
Govt. Jr. College, Malkajgiri, Secundrabad.**

Price : Rs. /-

Printed in India
Laser Typeset Reformatted by **SINDOOR GRAPHICS**, Dilsukhnagar, Hyderabad-60.
Phone : 24047464

CONTENTS

S.No.	Chapter Name	Page No.s
1.	Study of pattern generator and its use	1-4
2.	Study of wobuloscope and its use for alignment of T.V. receiver	5-6
3.	Study of operating controls and servicing controls of B/W T.V. and typical voltages.	7-11
4.	Tracking of different stages in B/W T.V. Receiver	12-13
5.	Familiarisation of different stages with transistors, IC's used in B/W T.V., typical voltages.	14-20
6.	Tracing of different stages of colour T.V. receiver	21-22
7.	Familiarisation of different stages with transistors, IC's used in colour T.V. and typical voltages.	23-29
8.	Measurement of picture tube voltages of B/W colour T.V. and picture adjustment.	30-31
9.	Assemble erection of T.V. antenna	32-33
10.	Front panel controls and adjustments	34-35
11.	T.V. picture, sound adjustments by using pattern generator	36-37
12.	Study the faults in various stages of B/W T.V. and rectification	38-40
13.	Rectify the given faults in various stages of colour T.V.	41-42
14.	Study of SMPS and measurement of the output voltages	43-45
15.	Identify the stages of SMPS, and mention the faults in SMPS and rectification of the faults.	46-47
16.	Study of different types of tuners	48-50